

Plastizität und Schädigung bei polaren und nicht-polaren Kontinua

Vom Fachbereich Bauingenieurwesen und Geodäsie
der Technischen Universität Darmstadt
zur Erlangung der Lehrbefugnis
für das Fach Mechanik
genehmigte

Habilitationsschrift

von

Dr. rer. nat. Paschalis Grammenoudis

aus Karlsruhe

1. Gutachter:

Prof. Dr.-Ing. Ch. Tsakmakis

2. Gutachter:

Prof. Dr.-Ing. St. Diebels

Tag der Einreichung:

27.03.2009

Tag der mündlichen Prüfung:

01.07.2009

Darmstadt 2009

D 17

Danksagung

Die vorliegende Arbeit entstand während meiner Tätigkeit als wissenschaftlicher Mitarbeiter an der Technischen Universität Darmstadt.

Meinen besonderen Dank möchte ich Herrn Prof. Dr.-Ing. Ch. Tsakmakis aussprechen. Ich darf mich bei ihm an dieser Stelle herzlich bedanken für seine Förderung und Unterstützung und natürlich auch für die Übernahme des Gutachtens.

Ebenso danke ich Herrn Prof. Dr.-Ing. St. Diebels für das Interesse an dieser Arbeit und für die freundliche Übernahme des zweiten Gutachtens.

Außerdem möchte ich mich bei allen Kollegen für das angenehme und freundschaftliche Arbeitsklima bedanken.

Schließlich danke ich meiner Frau Christina für Ihre uneingeschränkte Unterstützung.

Düsseldorf, im September 2009

Paschalis Grammenoudis

Inhaltsverzeichnis

1	Einführung und Übersicht	1
2	Eigene Veröffentlichungen	5
2.1	Artikel in Zeitschriften	5
2.2	Artikel in Konferenzbänden	7
	Diskutierte Veröffentlichungen	9
3	Micropolar plasticity theories and their classical limits. Part I	11
3.1	Introduction	12
3.2	Preliminaries	13
3.3	Balance Laws	15
3.3.1	Macro- and microcontinuum	15
3.3.2	Conservation of mass for the macroscopic continuum	18
3.3.3	Balance laws of momentum and moment of momentum	19
3.4	The micropolar plasticity model	19
3.5	Classical limit of micropolar elasticity	22
3.6	Classical limit of the micropolar plasticity model	26
3.6.1	Elasticity law – flow rule – additive decomposition of strain	26
3.6.2	Hardening rules	28
3.7	Concluding remarks	28
3.8	Derivation of balance laws for momentum and moment of momentum	29
3.8.1	Hamilton’s principle for pure elastic materials	29
3.8.2	Variation of \mathbf{u} and $\bar{\mathbf{R}}$	30
3.8.3	Kinetic energy of the macroscopic continuum	30
3.8.4	Work of the internal forces	34
3.8.5	Work of the external forces	35
3.8.6	Local equations of motion	35
4	Micropolar plasticity theories and their classical limits. Part II	37
4.1	Introduction	38
4.2	The limiting classical model (LCM)	39
4.3	A standard classical model (SCM)	39
4.4	Eulerian form of the two models	40
4.5	Comparative study of the two models	41
4.5.1	Uniaxial tension-compression loading	42
4.5.2	Tension-compression loading of a notched circular specimen	43
4.5.3	Simple Shear	47
4.5.4	Torsional loading	50

4.6	Concluding remarks	51
5	Isotropic hardening in micropolar plasticity	53
5.1	Introduction	54
5.2	The micropolar plasticity model	55
5.3	Isotropic hardening accounting separately for strain and rotation gradient effects	57
5.4	Experimentally observed results for torsional and uniaxial loadings	59
5.5	Predicted responses for torsional loading of circular cylinders	61
5.6	Concluding remarks	67
6	Continuum damage models based on energy equivalence. Part I	69
6.1	Introduction	70
6.2	Preliminaries – elasto-plastic constitutive models	71
6.3	Basic assumptions	74
6.4	Principle of strain equivalence	76
6.5	Proposed energy equivalence principle	79
6.5.1	Yield function – flow rule	82
6.5.2	Hardening rules	83
6.5.3	Dissipation inequality – dissipation potential	84
6.6	Discussion of the model	84
6.6.1	Comparison of the models according to strain and energy equivalence	85
6.6.2	Parameter studies	89
6.7	Concluding remarks	93
7	Continuum damage models based on energy equivalence. Part II	95
7.1	Introduction	96
7.2	Viscoplasticity part of the model	97
7.2.1	General anisotropic structure	97
7.2.2	Cubic symmetry	99
7.3	Coupling with damage – energy equivalence principle	100
7.3.1	Energy equivalence principle	102
7.3.2	Free energy functions	104
7.3.3	Yield function – flow rule	104
7.3.4	Hardening rules	105
7.3.5	Evolution equation for damage	106
7.4	Examples	108
8	Use of a continuum damage model based on energy equivalence	117
8.1	Introduction	118
8.2	Constitutive model	119
8.2.1	Fictitious undamaged material	119
8.2.2	Modeling of damage effects	120
8.3	Examples	123
8.3.1	Multiple notched circular specimen under cyclic loading conditions	124
8.3.2	Plate with multiple holes under cyclic loading conditions	130
9	Incompatible deformations – plastic intermediate configuration	137
9.1	Introduction	138

9.2	Preliminaries	139
9.3	Basic kinematic relations	140
	9.3.1 Reference and actual configuration	140
	9.3.2 Deformation gradient tensor	142
9.4	Local deformations	143
9.5	Convective coordinates	145
9.6	Relative gradient	146
9.7	Covariant derivatives related to incompatible deformations	149
	9.7.1 Transformation of covariant derivatives – relative covariant derivative	149
	9.7.2 Covariant derivatives with respect to local deformations	151
	9.7.3 Covariant derivatives along material lines	153
9.8	Use of spatial derivatives in gradient plasticity	156
	9.8.1 Non-polar continua	156
	9.8.2 Micropolar continua	162
9.9	Covariant derivative	169
9.10	Torsion, Riemann curvature tensor	172
9.11	Transformation of relative gradients under change of basis	173

10 Plastic intermediate configuration and related spatial differential operators in micromorphic plasticity 175

10.1	Introduction	176
10.2	Notation	177
10.3	Kinematic of micromorphic continuum	178
	10.3.1 Reference and actual configuration	178
	10.3.2 Micro- and macrodeformation gradient	180
	10.3.3 Basis systems on $\mathcal{R}_{\mathcal{R}}, \mathcal{R}_t$	181
	10.3.4 Micromorphic curvature tensors	182
10.4	Decompositions of deformation	184
	10.4.1 Multiplicative decomposition of the macro- and the microdeformation gradient tensors into elastic and plastic parts	184
	10.4.2 Basis systems on \hat{R}_t	185
	10.4.3 Additive decomposition of Δ_c	186
10.5	Spatial differential operators on \hat{R}_t	186
	10.5.1 Relative gradient on \hat{R}_t	186
	10.5.2 Relative gradient as transformed covariant derivative	187
	10.5.3 Relative gradient – relation to local deformations	189
	10.5.4 Relative covariant derivative on \hat{R}_t	190
10.6	Elastic and plastic parts of the micromorphic curvature tensor	191
10.7	Concluding remarks	192
10.8	Manifold with connection	193

11 Micromorphic continuum. Part I 195

11.1	Introduction	196
11.2	Preliminaries	198
11.3	Kinematic	200
	11.3.1 Micromorphic continuum	200
	11.3.2 Deformation	202
	11.3.3 Coordinate systems	203

11.3.4	Strain energy function in micromorphic hyperelasticity	205
11.4	Balance laws	206
11.4.1	Conservation of mass for the micro- and the macroscopic continuum	206
11.4.2	Balance laws of momentum and moment of momentum	207
11.4.3	Balance of mechanical energy	208
11.5	Dual Variables	209
11.5.1	Equivalent classes of strain and micromorphic curvature tensors	209
11.5.2	Associated rates for strain and micromorphic curvature tensors	214
11.5.3	Dual stress tensors and their associated rates	215
11.6	Derivation of balance laws for momentum and moment of momentum	218
11.6.1	Hamilton's principle for pure elastic materials	219
11.6.2	Variation of \mathbf{u} and \mathbf{f}	219
11.6.3	Kinetic energy of the macroscopic continuum	220
11.6.4	Work of the internal forces	223
11.6.5	Work of the external forces	225
11.6.6	Local equations of motion	225
12	Micromorphic continuum. Part II	227
12.1	Introduction	228
12.2	Decompositions of deformation	229
12.2.1	Multiplicative decomposition of the macro- and the microdeformation gradient tensors into elastic and plastic parts	229
12.2.2	Basis systems on \hat{R}_t	231
12.2.3	Additive decompositions of the strain tensors	231
12.2.4	Additive decomposition of the micromorphic curvature tensors	233
12.2.5	Stress tensors and their associated rates	235
12.3	Thermodynamical framework for micromorphic plasticity	236
12.3.1	Elasticity laws – dissipation inequality	236
12.3.2	Postulate of Il'iushin – flow rule for plasticity	240
12.3.3	Flow rule for viscoplasticity	243
12.3.4	Hardening rules	243
12.3.5	Coupling with damage	247
12.3.6	Simple constitutive relations	250
12.4	Transformations under rigid body rotations	253
12.5	Conditions for the validity of Il'iushin's postulate	254
12.6	Decompositions of strain and micromorphic curvature tensors – dual stress and couple stress tensors	257
12.7	Kinematic hardening – Decompositions of plastic strain and micromorphic curvature tensors	266
13	Micromorphic continuum. Part III	273
13.1	Introduction	274
13.2	Finite element implementation	277
13.2.1	Weak form of equilibrium equations	277
13.2.2	Time integration	277
13.2.3	Linearization	278
13.2.4	Discretization	281
13.3	Examples	282

13.3.1 Pure micromorphic elasticity	283
13.3.2 Micromorphic plasticity coupled with damage	291
13.4 Concluding remarks	296
Literaturverzeichnis	297

1 Einführung und Übersicht

In der klassischen Kontinuumsmechanik wird davon ausgegangen, dass die Spannungsantwort in einem materiellen Punkt einzig und allein von der vergangenen Deformationsgeschichte des betrachteten Punktes abhängig ist. Benachbarte Punkte spielen keine Rolle. Mit solchen "lokalen" Theorien, im Weiteren auch als klassische bzw. nicht-polare Theorien bezeichnet, ist man in der Lage, eine Vielzahl von Aufgaben der Strukturmechanik mit zum Teil komplexer Geometrie zu behandeln. Dabei werden sehr oft klassische Plastizitätstheorien für große Deformationen verwendet. Sie werden mittels der multiplikativen Zerlegung des Deformationsgradienten in elastische und plastische Anteile dargestellt. Diese Zerlegung führt eine sogenannte plastische Zwischenkonfiguration ein, die bei der Formulierung von thermodynamisch konsistenten Plastizitätstheorien eine entscheidende Rolle spielt.

Bei vielen Aufgaben der Strukturmechanik ist die Berücksichtigung der Schädigung und des Versagens von großer Bedeutung. Auf Basis phänomenologischer konstitutiver Gesetze erfolgt die Kopplung mit Schädigungseffekten sehr oft auf Grundlage der Konzepte der Kontinuumschädigungsmechanik. Diese wurden entwickelt, um das lokale Versagen von Bauteilen unter mechanischer und thermischer Belastung vorherzusagen. Bei diesen Schädigungsmodellen wird neben dem realen geschädigten Material ein fiktives ungeschädigtes Material betrachtet. Die Formulierung der Theorie geschieht mittels sogenannter effektiver Zustandsvariablen. Die Definition dieser Variablen basiert entweder auf dem Konzept der effektiven Spannung für das reale Material kombiniert mit der Hypothese der Verzerrungsäquivalenz für das reale und das fiktive Material oder auf dem Konzept der effektiven Verzerrung für das reale Material kombiniert mit der Hypothese der Spannungsäquivalenz für das reale und das fiktive Material. Außerdem kann das Konzept der effektiven Spannung und effektiven Verzerrung für das reale Material mit der Hypothese der Energieäquivalenz für das reale und das fiktive Material kombiniert werden. Das letzte Konzept gewinnt an Bedeutung bei der Untersuchung anisotroper Schädigung bei anisotropen Materialverhalten, wie es bei einkristallinen Materialien experimentell beobachtet wird.

Mit dem heutigen Kenntnisstand wird es immer offensichtlicher, dass sich bei immer kleiner werdenden Bauteilgrößen oder sogenannten Lokalisierungen der Deformation die Möglichkeiten lokaler bzw. nicht-polarer Theorien erschöpfen. In diesen Fällen ist neben dem betrachteten Punkt auch seine Umgebung für die Spannungsantwort zuständig. Eine Möglichkeit, diesen Sachverhalt im Materialverhalten zu berücksichtigen, besteht in der Einführung höherer Gradienten im System der Materialgleichungen. Das heißt, dass nichtlokale Materialgleichungen herangezogen werden müssen. Bei der Entwicklung einer nichtlokalen Kontinuumsmechanik leisten die polaren Kontinua einen wichtigen Beitrag. Dabei ist die Definition der Mikrostruktur von großer Bedeutung. Zwei Sonderfälle sind wegen ihrer einfachen Form sehr wichtig. Der erste Fall ergibt sich, wenn das Mikrokontinuum einen starren Körper darstellt, während im zweiten Fall das Mikrokontinuum nur homogene Deformationen erfährt. Solche Modellkörper werden als mikropolare oder mikromorphe Kontinua bezeichnet und stellen phänomenologische Beiträge zur Formulierung nichtlokaler Materialgleichungen dar.

Die Vorgehensweise bei der Entwicklung einer Plastizitäts- und Schädigungstheorie bei polaren Kontinua ist analog der bei klassischen nicht-polaren Kontinua. Ausgangspunkt ist in diesem Fall die multi-

plikativer Zerlegung des Deformationsgradienten und des Deformationsgradienten des Mikrokontinuums in entsprechende elastische und plastische Anteile. Die Berücksichtigung der Schädigung basiert auch auf den Konzepten der Kontinuumsschädigungsmechanik.

Die vorliegende Habilitationsschrift befasst sich mit verschiedenen Fragestellungen, die sich bei der Untersuchung von Plastizität und Schädigung bei polaren und nicht-polaren Kontinua ergeben. Sie basiert auf Veröffentlichungen des Autors, die nach dem Jahr 2003 entstanden sind. Eine ausführliche Aufstellung wird in Kapitel 2 gegeben. Die daraus ausgewählten Artikel werden im Folgenden ausführlicher vorgestellt. Das Layout der Veröffentlichungen wurde vereinheitlicht und die Literaturliste wurde entfernt und ans Ende der Habilitationsschrift angehängt.

Der Grenzübergang eines mikropolaren Plastizitätsmodells zu einem klassischen Plastizitätsmodell ist Gegenstand der Untersuchungen in **Micropolar plasticity theories and their classical limits. Part I: Resulting model** und **Part II: Comparison of responses predicted by the limiting and a standard classical model** (Ziffer 5 und 6 in Kapitel 2.1). Ausgangspunkt ist das mikropolare Plastizitätsmodell für große Deformationen (Ziffer 1 bis 3 und 7 in Kapitel 2.1), das auf der multiplikativen Zerlegung des makroskopischen Gradienten der Deformation und der mikropolaren Rotation in elastische und plastische Anteile basiert. Die Theorie ist thermodynamisch konsistent und berücksichtigt isotrope und kinematische Verfestigung. Charakteristisch für mikropolare Modelle sind die Einbeziehung von mikropolaren Krümmungstensoren, die Tatsache, dass der Spannungstensor nicht mehr symmetrisch ist, und das Vorhandensein von Momentenspannungen. Es werden die Bedingungen ausgearbeitet, unter denen sich das mikropolare Kontinuum einem klassischen Kontinuum annähert. Das heißt die Plastizitätstheorie wird mit einem symmetrischen Cauchy'schen Spannungstensor und verschwindenden Momentenspannungen beschrieben. Es stellte sich heraus, dass die mikropolare elastische Rotation und der plastische "microgyration tensor" jeweils gleich sind zu der elastischen materiellen Rotation und dem plastischen Spin. Außerdem werden Evolutionsgleichungen für die kinematische Verfestigung gewonnen, die mit Hilfe gemischter objektiver Oldroyd-Zeit-Ableitungen formuliert werden. Dies steht im Gegensatz zu anderen klassischen Modellen, die mit der unteren oder oberen Oldroyd-Zeit-Ableitung arbeiten. Ein Vergleich liefert unterschiedliche Ergebnisse vor allem in den sogenannten Effekten zweiter Ordnung. Ein weiterer Aspekt dieser Veröffentlichungen ist die Herleitung der Bilanzgleichungen für ein mikropolares Kontinuum. Dabei wird im Unterschied zur bisher vorhandenen Literatur das Mikrokontinuum mit beliebigen Dimensionen angenommen. Insbesondere kann sich das Mikrokontinuum über den Bereich des Makrokontinuums ausdehnen. Über Volumen- oder Massenmittelungen und Anwendung des Hamiltonschen Prinzips werden für reine Elastizität die Feldgleichungen hergeleitet.

In **Isotropic hardening in micropolar plasticity** (Ziffer 9 in Kapitel 2.1) geht es um die Modellierung von isotroper Verfestigung in der mikropolaren Plastizitätstheorie. In den früheren Arbeiten (Ziffer 1 bis 3 und 7 in Kapitel 2.1) erfasst die isotrope Verfestigung in einheitlicher Weise Beiträge des Deformations- und des Krümmungstensors, während die kinematische Verfestigung diese separat berücksichtigt. Es hat sich herausgestellt, dass die damit beschriebenen Längenskaleneffekte mit den experimentellen Resultaten nicht kompatibel sind. Um Verbesserungen zu erzielen wird jetzt die isotrope Verfestigung additiv aus zwei Teilen gebildet, die jeweils aus reinen Deformationen und reinen Krümmungsanteilen bestehen. Somit ist es möglich separat Effekte infolge der Deformation und infolge des mikropolaren Krümmungsmaßes in der isotropen Verfestigung zu berücksichtigen. Eine Parameterstudie hat gezeigt, dass die neue Version der isotropen Verfestigung in der Lage ist, das experimentell beobachtete Verhalten in realistischerer Weise wiederzugeben.

Die Herleitung des Konzeptes der Energieäquivalenz im Rahmen der Kontinuumsschädigungsmechanik,

die Anwendung für den Fall anisotroper Schädigung bei anisotropen Materialverhalten und die Diskussion bauteilnaher Beispiele sind der Gegenstand der Untersuchungen in **Properties of a class of continuum damage models**¹, **Continuum damage models based on energy equivalence. Part I: Isotropic material response, Part II: Anisotropic material response** und **Use of a continuum damage model based on energy equivalence to predict the response of a single-crystal superalloy** (Ziffer 4, 10, 11 und 13 in Kapitel 2.1). Bei der Herleitung der Energieäquivalenz-Methode zur Modellierung von Schädigung im Material wird zuerst der weniger komplizierte Fall des isotropen Materialverhaltens betrachtet. Ansonsten wird ein elasto-plastisches Materialmodell angenommen, das isotrope und kinematische Verfestigung berücksichtigt. Zur Erfassung einer sich entwickelnden Erniedrigung der mechanischen Eigenschaften mit zunehmender Beanspruchungsdauer werden die Materialmodelle um Schädigungsvariablen erweitert und Verformungs- und Schädigungsmodelle miteinander gekoppelt. Um Unterschiede zu anderen Modellen der Kontinuumsschädigung deutlich zu machen, wird zu Beginn isotrope Schädigung herangezogen, die mit einer skalaren Schädigungsvariablen formuliert wird. Bei der Anwendung des Prinzips wird die Äquivalenz der konstitutiven Gleichungen für die plastische und die Verfestigungsleistung postuliert. Als Folge erhält man eine Familie von Fließfunktionen und die Evolutionsgleichungen für die Verfestigungsvariablen. Ein Vergleich der Ergebnisse für eine kreisförmige gekerbte Zugprobe entsprechend der Konzepte der verallgemeinerten Energieäquivalenz und der in der Literatur etablierten Dehnungsäquivalenz zeigte, dass Unterschiede praktisch nicht vorhanden sind. Das Energieäquivalenzprinzip wurde erweitert um einerseits anisotrope Viskoplastizität unter Berücksichtigung statischer Erholung in den Evolutionsgleichungen für die Verfestigungsvariablen und andererseits anisotrope Schädigung zu beschreiben. Die Anisotropie wird mit Hilfe von Tensoren vierter Ordnung formuliert, die in der Elastizität, der Fließfunktion und der kinematischen Verfestigung eingearbeitet werden. Die anisotrope Schädigung wird mittels des Schädigungseffektensors in den effektiven Variablen berücksichtigt. Das resultierende System der konstitutiven Gleichungen wurde zur Berechnung der Spannungs- und Schädigungsverteilung für eine Einkristall-Superlegierung bei komplexen Belastungsgeschichten und komplexer Bauteilgeometrie herangezogen. Obwohl keine professionelle Anpassung der Materialparameter durchgeführt wurde, werden die prinzipiellen Tendenzen im Materialverhalten im Vergleich zu experimentellen Befunden hinreichend genau wiedergegeben.

Klassische Plastizitätstheorien für nicht-polare Kontinua werden mittels der multiplikativen Zerlegung des Deformationsgradienten in elastische und plastische Anteile dargestellt. Diese Zerlegung führt eine sogenannte plastische Zwischenkonfiguration ein, die nicht einer realen Deformation entspricht und nur konzeptuellen Charakter hat. Bei polaren Kontinua basiert die Zerlegung der Deformation in elastische und plastische Anteile auf der multiplikativen Zerlegung des Deformationsgradienten sowohl des makroskopischen materiellen Körpers als auch der angenommenen inhärenten Mikrostruktur. Dadurch wird ebenfalls eine sogenannte plastische Zwischenkonfiguration eingeführt. Die differentialgeometrische Charakterisierung der Deformation ist bei der Formulierung von konstitutiven Gleichungen für Plastizität sehr wichtig. Die Untersuchung basiert auf den Begriffen der Metrik, des Zusammenhangs und der Riemannschen Krümmung und spielt eine wichtige Rolle bei der Ermittlung der elastischen und plastischen Anteile für die Verzerrungs- und Krümmungstensoren. Differentialgeometrische Aspekte der plastischen Zwischenkonfiguration und der Kinematik polarer und nicht-polarer Kontinua werden in **Incompatible deformations - plastic intermediate configuration** und **Plastic intermediate configuration and related spatial differential operators in micromorphic plasticity** (Ziffer 8 und 12 in Kapitel 2.1) diskutiert. Der plastische Anteil der Deformation wird als eine lokale Deformation betrachtet und wichtige geometrische Eigenschaften werden durch die Definition einer relativen kovarianten Ableitung erfasst. Mit Hilfe dieser Ableitung werden die polaren Krümmungs-

¹Um den Umfang der vorliegenden Arbeit zu beschränken und um Wiederholungen zu vermeiden wird diese Veröffentlichung nicht explizit aufgeführt.

tensoren additiv in elastische und plastische Anteile zerlegt. Dies wird sowohl für mikropolare als auch für mikromorphe Plastizität demonstriert. Bei der Formulierung von konstitutiven Gleichungen ist der Riemannsche Krümmungstensor von großer Bedeutung, da er nicht zu verschwinden braucht. Geht man aber von einem verschwindenden Riemannschen Krümmungstensor aus, dann braucht man keine Evolutionsgleichungen für den plastischen Krümmungstensor zu formulieren. Er ergibt sich aus den zugehörigen Kompatibilitätsbedingungen.

Bei den Veröffentlichungen **Micromorphic continuum. Part I: Strain and stress tensors and their associated rates**, **Part II: Finite deformation plasticity coupled with damage** und **Part III: Small deformation plasticity coupled with damage** (Ziffer 14, 15 und 16 in Kapitel 2.1) geht es um einen umfassenden Überblick über mikromorphe Kontinua. Mikromorphe Kontinua basieren auf der Vorstellung, dass jedem makroskopischen materiellen Punkt eine Mikrostruktur zugeordnet wird. Diese erfährt während der Belastung eine reine homogene Deformation. Über Volumen- oder Massenmittelungen und Anwendung des Hamiltonschen Prinzips werden die Feldgleichungen (Bilanzgleichungen) für Impuls und Drehimpuls sowie geeignete Randbedingungen hergeleitet. Dies gilt zunächst für reine Elastizität, die hergeleiteten Bilanzgleichungen haben aber universellen Charakter und gelten auch für alle mikromorphen Kontinua der angenommenen Struktur. Ein weiterer wichtiger Punkt ist die geometrische Deutung der Verzerrungs- und Krümmungstensoren und die eindeutige Zuordnung zwischen Spannungen und Dehnungen. Hierzu wird das Konzept der dualen Variablen in verallgemeinerter Form herangezogen. Dies erlaubt zu jeder Spannungs- oder dehnungsartigen Variablen auch eine bestimmte objektive Zeitableitung zu assoziieren. Elastisch-plastische Materialeigenschaften werden dadurch definiert, dass der makroskopische Deformationsgradient und der Deformationsgradient der Mikrostruktur jeweils in elastische und plastische Anteile multiplikativ zerlegt werden. Dies führt auf eine verallgemeinerte Zwischenkonfiguration sowie auf additive Zerlegungen der gesamten mikromorphen Verzerrung in elastische und plastische Anteile. Der zweite Hauptsatz der Thermodynamik wird relativ zur Zwischenkonfiguration überprüft und liefert das Elastizitätsgesetz. Kinematische und isotrope Verfestigung werden so modelliert, dass Effekte infolge der Verformung und Effekte infolge höherer Gradienten der Verformung (mikromorphe Krümmung) jeweils separat erfasst werden. Entsprechende Evolutionsgleichungen folgen als hinreichende Bedingungen für die Erfüllung des zweiten Hauptsatzes. Die Fließregel hat die Form einer Normalenregel und die Fließfunktion wird völlig analog zu entsprechenden Ansätzen der mikropolaren Plastizität angesetzt. Außerdem wird noch skizziert, wie isotrope Schädigung im Materialmodell berücksichtigt wird. Dies geschieht mittels des Konzeptes der effektiven Spannung kombiniert mit der Dehnungsäquivalenz². Abschließend wurde das mikromorphe Plastizitätsmodell mit Schädigung für kleine Deformationen formuliert und einige Beispiele wie die Balkenbiegung und die gelochte Platte diskutiert.

²Das mikropolare Plastizitätsmodell wurde in **Finite Deformation Micropolar Plasticity Coupled with Scalar Damage** (Ziffer 2 in Kapitel 2.2) ebenfalls mit isotroper Schädigung gekoppelt. Um den Umfang der vorliegenden Arbeit zu begrenzen wird diese Veröffentlichung nicht explizit aufgeführt.

2 Eigene Veröffentlichungen

2.1 Artikel in Zeitschriften (begutachtet)

1. P. Grammenoudis, Ch. Tsakmakis
"Hardening rules for finite deformation micropolar plasticity: Restrictions imposed by the second law of thermodynamics and the postulate of Il'iushin"
Continuum Mechanics and Thermodynamics, 13 (2001) 5, 325–363
2. P. Grammenoudis, Ch. Tsakmakis
"Finite element implementation of large deformation micropolar plasticity exhibiting isotropic and kinematic hardening effects"
International Journal for Numerical Methods in Engineering, 62 (2005) 12, 1691–1720
3. P. Grammenoudis, Ch. Tsakmakis
"Predictions of microtorsional experiments by micropolar plasticity"
Proceedings of the Royal Society A: Mathematical, Physical and Engineering Sciences, 461 (2005) 2053, 189–205
4. P. Grammenoudis, Ch. Tsakmakis
"Properties of a class of continuum damage models"
WSEAS Transactions on Mathematics, 5 (2006) 3, 329–333
5. P. Grammenoudis, Ch. Tsakmakis
"Micropolar plasticity theories and their classical limits. Part I: Resulting model"
Acta Mechanica, 189 (2007) 3-4, 151–175
6. P. Grammenoudis, Ch. Sator, Ch. Tsakmakis
"Micropolar plasticity theories and their classical limits. Part II: Comparison of responses predicted by the limiting and a standard classical model"
Acta Mechanica, 189 (2007) 3-4, 177–191
7. P. Grammenoudis, Ch. Tsakmakis
"Influence of Hardening on Size Effects in Plasticity"
Journal of Mechanical Behaviour of Materials, 18 (2007) 2, 105–112
8. P. Grammenoudis, Ch. Tsakmakis
"Incompatible deformations – plastic intermediate configuration"
ZAMM - Journal of Applied Mathematics and Mechanics / Zeitschrift für Angewandte Mathematik und Mechanik, 88 (2008) 5, 403–432

9. P. Grammenoudis, Ch. Tsakmakis
"Isotropic hardening in micropolar plasticity"
Archive of Applied Mechanics (Ingenieur Archiv), 79 (2009) 4, 323–334
10. P. Grammenoudis, D. Reckwerth, Ch. Tsakmakis
"Continuum damage models based on energy equivalence. Part I: Isotropic material response"
International Journal of Damage Mechanics, 18 (2009), 31–63
11. P. Grammenoudis, D. Reckwerth, Ch. Tsakmakis
"Continuum damage models based on energy equivalence. Part II: Anisotropic material response"
International Journal of Damage Mechanics, 18 (2009), 65–91
12. P. Grammenoudis, Ch. Tsakmakis
"Plastic intermediate configuration and related spatial differential operators in micromorphic plasticity"
Mathematics and Mechanics of Solids, in press
Online First DOI 10.1177/1081286509104829
13. P. Grammenoudis, D. Reckwerth, Ch. Tsakmakis
"Use of a continuum damage model based on energy equivalence to predict the response of a single-crystal superalloy"
Journal of Engineering Materials and Technology, in press
14. P. Grammenoudis, Ch. Tsakmakis
"Micromorphic continuum. Part I: Strain and stress tensors and their associated rates"
International Journal of Non-Linear Mechanics, 44 (2009), 943–956
15. P. Grammenoudis, D. Hofer, Ch. Tsakmakis
"Micromorphic continuum. Part II: Finite deformation plasticity coupled with damage"
International Journal of Non-Linear Mechanics, 44 (2009), 957–974
16. P. Grammenoudis, D. Hofer, Ch. Tsakmakis
"Micromorphic continuum. Part III: Small deformation plasticity coupled with damage"
International Journal of Non-Linear Mechanics, accepted for publication
17. S. Bauer, M. Schäfer, P. Grammenoudis, Ch. Tsakmakis
"Three-Dimensional Finite Elements for Large Deformation Micropolar Elasticity"¹
Computer Methods in Applied Mechanics and Engineering, submitted for publication

¹Diese Veröffentlichung gibt die ersten systematischen Untersuchungen der Finite-Elemente-Implementation des mikropolaren Kontinuums wieder und stellt den Anfang weiterer Untersuchungen dar und wird in dieser Habilitationsschrift nicht explizit berücksichtigt.

2.2 Artikel in Konferenzbänden (nicht begutachtet)

1. P. Grammenoudis, D. Hofer, Ch. Tsakmakis
"Some Aspects of a micromorphic plasticity theory"
in "7th National Congress on Mechanics, Proceedings Volume II"
Hrsg. A. Kounadis, C. Providakis, G. Exadaktylos, Chania, Crete, 2004, 170-175
2. P. Grammenoudis, Ch. Tsakmakis
"Finite Deformation Micropolar Plasticity Coupled with Scalar Damage"
in "Computational Methods for Coupled Problems in Science and Engineering"
Hrsg. M. Papadrakis, E. Onate, B. Schrefler, Santorin, Greece, May 2005, cdrom
3. P. Grammenoudis, Ch. Tsakmakis
"Classical limits of a micropolar plasticity model"
in "5th GRACM International Congress on Computational Mechanics, Proceedings Volume 1"
Hrsg. G. Georgiou, P. Papanastasiou, M. Papadrakis, Limassol, Zypern, Juli 2005, 511-518
4. P. Grammenoudis, Ch. Tsakmakis
"Energy equivalence approach in continuum damage mechanics"
in "Computational Methods for Coupled Problems in Science and Engineering II"
Hrsg. E. Onate, M. Papadrakakis, B. Schrefler, CIMNE, Barcelona, 2007, 425-428
5. P. Grammenoudis, Ch. Tsakmakis
"Continuum damage theories according to energy equivalence principle"
in "8th HSTAM International Congress on Mechanics, Proceedings Volume I"
Hrsg. N. Bazeos, D.L. Karabalis, D. Polyzos, D.E. Beskos, J.T. Katsikadelis, Patras, Greece, 2007, 279-284

Diskutierte Veröffentlichungen

3 Micropolar plasticity theories and their classical limits. Part I: Resulting model

P. Grammenoudis, Ch. Tsakmakis

Acta Mechanica, 189 (2007) 3-4, 151-175

Micropolar plasticity theories and their classical limits. Part I: Resulting model

P. Grammenoudis, Ch. Tsakmakis

**Darmstadt University of Technology, Institute of Continuum Mechanics,
Hochschulstraße 1, 64289 Darmstadt, Germany**

Abstract

We focus attention on finite deformation micropolar plasticity theories, developed previously, which rely upon the multiplicative decomposition into elastic and plastic parts of both the macroscopic deformation gradient and the micropolar rotation tensor. The theories are thermodynamically consistent and exhibit isotropic and kinematic hardening effects. Conditions are worked out under which the micropolar continuum approaches a classical limit, i.e., a plasticity theory with symmetric Cauchy stress tensor and vanishing couple stress tensors. It turns out that, according to the assumptions made, on the one hand the elastic micropolar rotation is equal to the elastic rotation of the overall material. On the other hand, the plastic microgyration tensor is equal to the plastic material spin. Generally, the micropolar rotation is not equal to the material rotation as it is often assumed in the literature. Also, kinematic hardening rules are obtained, which are formulated by mixed Oldroyd objective time derivatives.

3.1 Introduction

We consider the finite deformation micropolar plasticity theory proposed in Grammenoudis and Tsakmakis [67, 69, 70]. This theory, which is thermodynamically consistent, exhibits isotropic and kinematic hardening effects and makes use of the multiplicative decomposition into elastic and plastic parts of both the deformation gradient tensor of the overall material and the micropolar rotation tensor. Note that a multiplicative decomposition of the micropolar rotation was introduced for the first time by Steinmann [149]. Geometrically, the micropolar rotation is interpreted to describe the motion of a microstructure (microcontinuum) attached to every point of the macroscopic continuum (see [49, 46, 122]). Characteristic features of micropolar models are the incorporation of curvature measures by using the micropolar rotation and its gradient. Moreover, so-called couple stress tensors appear, aside from the classical Cauchy stress tensor, the latter being now non-symmetric.

The aim of the present paper is to establish classical limits, which may be obtained from the micropolar plasticity theory. In other words, we examine for which conditions the Cauchy stress tensor becomes symmetric while the couple stress tensor vanishes. To this end, it is necessary to refer to the balance equations of momentum and of moment of momentum. For finite deformations, Eringen and Suhubi [49] and Eringen [46] established these balance laws by using "macro-elements constructed by micro-elements". However, from their notion of microcontinuum there seem to arise some problems

whenever the microcontinuum is assumed to consist of a micro-element with continuously distributed mass. On the other hand, Mindlin proposed an elasticity theory in which the microstructure of the real material is modelled by embedding a microvolume in each particle of the overall material body. Unfortunately, it is not clear in this theory how the microvolume is related to the macroscopic particle. One might presume that rather the microvolume must be included in the particle. Moreover, the deformations are supposed to be small, and as we shall see, a lot of care has to be put into details in order to extend such theories to finite deformations.

In our work we adopt the approach of Mindlin for establishing the balance laws of momentum and of moment of momentum, in a fashion which allows the microcontinuum to exhibit arbitrary finite dimensions. This accommodates more to the concepts of phenomenological continuum mechanics, when modelling microphysical properties. It is examined that basic field equations introduced by Eringen for the case of non-linear geometry may be obtained by the version of Mindlin's theory as accommodated here. It turns out that for the deformation and curvature measures used in the micropolar plasticity theory, the classical limiting models are best represented by employing the Biot stress tensor in the elasticity law and mixed Oldroyd objective time derivatives in the kinematic hardening rule. Additionally, the micropolar elastic rotation and the plastic microgyration tensors are equal, respectively, to the elastic macroscopic material rotation and the plastic macroscopic material spin. It should be emphasized that the material and micropolar rotation become not equal in the limiting case in contrast to some other works in the literature.

3.2 Preliminaries

We consider isothermal deformations and write $\dot{\varphi}(t)$ for the material time derivative of a function $\varphi(t)$, where t is the time. An explicit reference to space will be dropped in most part of the paper. Commonly, the same symbol is used to designate a function and the value of that function at a point. However, if we deal with different representations of the same function, then use will often be made of different symbols.

Letters set in bold face designate vectors or second-order tensors. In particular, $\mathbf{a} \cdot \mathbf{b}$, $\mathbf{a} \times \mathbf{b}$ and $\mathbf{a} \otimes \mathbf{b}$ denote the inner, the vector and the tensor product of the vectors \mathbf{a} and \mathbf{b} , respectively. For second-order tensors \mathbf{A} and \mathbf{B} , we write $\text{tr}\mathbf{A}$ for the trace, $\det \mathbf{A}$ for the determinant and \mathbf{A}^T for the transpose of \mathbf{A} , while $\mathbf{A} \cdot \mathbf{B} = \text{tr}(\mathbf{A}\mathbf{B}^T)$ is the inner product between \mathbf{A} and \mathbf{B} , and $\|\mathbf{A}\| = \sqrt{\mathbf{A} \cdot \mathbf{A}}$ is the Euclidean norm of \mathbf{A} . The Euclidean norm of a vector \mathbf{v} is given by $\|\mathbf{v}\| = \sqrt{\mathbf{v} \cdot \mathbf{v}}$. Furthermore,

$$\mathbf{1} = \delta_{ij} \bar{\mathbf{e}}_i \otimes \bar{\mathbf{e}}_j \quad (3.1)$$

represents the identity tensor of second-order, where δ_{ij} is the Kronecker-delta and $\{\bar{\mathbf{e}}_i\}$ is an orthonormal basis in the three-dimensional Euclidean vector space under consideration. All indices, unless otherwise specified, are referred to an orthonormal basis and have the range of the integers $(1, 2, 3)$, while summation over repeated indices is implied. Often use is made of notations of the form $(\mathbf{a})_i$, $(\mathbf{A})_{ij}$, \dots , for the components of vectors \mathbf{a} , second-order tensors \mathbf{A} , and so on. Also, we use the notation $\mathbf{A}^D = \mathbf{A} - \frac{1}{3}(\text{tr}\mathbf{A})\mathbf{1}$ for the deviator of \mathbf{A} and $\mathbf{A}^{T-1} = (\mathbf{A}^{-1})^T$, provided $\det \mathbf{A} \neq 0$.

Fourth-order and third-order tensors are denoted by calligraphic boldface letters. Let \mathcal{K} , \mathbf{A} , \mathbf{v} be respectively fourth-order, second-order and first-order (vector) tensors. Then the following will apply:

$$\mathbf{A}^2 = \mathbf{A}\mathbf{A} \quad , \quad \mathbf{A}^3 = \mathbf{A}\mathbf{A}\mathbf{A} \quad , \quad \dots \quad , \quad (3.2)$$

$$\mathcal{K}^T = \mathcal{K}_{ijkl} \bar{\mathbf{e}}_k \otimes \bar{\mathbf{e}}_l \otimes \bar{\mathbf{e}}_i \otimes \bar{\mathbf{e}}_j \quad , \quad (3.3)$$

$$\mathcal{K}[\mathbf{A}] = \mathcal{K}_{ijmn} A_{mn} \bar{\mathbf{e}}_i \otimes \bar{\mathbf{e}}_j \quad , \quad (3.4)$$

$$\mathbf{A}\mathbf{v} = A_{ij} v_j \bar{\mathbf{e}}_i \quad . \quad (3.5)$$

Thus, for second-order tensors \mathbf{A} , \mathbf{B} , and fourth-order tensor \mathcal{K} ,

$$\mathbf{A} \cdot \mathcal{K}[\mathbf{B}] = \mathbf{B} \cdot \mathcal{K}^T[\mathbf{A}] \quad . \quad (3.6)$$

In addition, we write \mathcal{I} for the fourth-order identity tensor,

$$\mathcal{I} = \delta_{im} \delta_{jn} \bar{\mathbf{e}}_i \otimes \bar{\mathbf{e}}_j \otimes \bar{\mathbf{e}}_m \otimes \bar{\mathbf{e}}_n \quad , \quad (3.7)$$

which satisfies the property

$$\mathcal{I} = \mathcal{E} + \mathcal{J} \quad , \quad (3.8)$$

with

$$\mathcal{E} = \mathcal{E}_{imjn} \bar{\mathbf{e}}_i \otimes \bar{\mathbf{e}}_m \otimes \bar{\mathbf{e}}_j \otimes \bar{\mathbf{e}}_n = \frac{1}{2} (\delta_{ij} \delta_{mn} + \delta_{in} \delta_{mj}) \bar{\mathbf{e}}_i \otimes \bar{\mathbf{e}}_m \otimes \bar{\mathbf{e}}_j \otimes \bar{\mathbf{e}}_n \quad , \quad (3.9)$$

$$\mathcal{J} = \mathcal{J}_{imjn} \bar{\mathbf{e}}_i \otimes \bar{\mathbf{e}}_m \otimes \bar{\mathbf{e}}_j \otimes \bar{\mathbf{e}}_n = \frac{1}{2} (\delta_{ij} \delta_{mn} - \delta_{in} \delta_{mj}) \bar{\mathbf{e}}_i \otimes \bar{\mathbf{e}}_m \otimes \bar{\mathbf{e}}_j \otimes \bar{\mathbf{e}}_n \quad . \quad (3.10)$$

Hence, for the symmetric and the skew-symmetric (anti-symmetric) part of an arbitrary second-order tensor \mathbf{A} , denoted respectively by \mathbf{A}_S and \mathbf{A}_A , we have

$$\mathbf{A}_S = \mathcal{E}[\mathbf{A}] \quad , \quad \mathbf{A}_A = \mathcal{J}[\mathbf{A}] \quad , \quad (3.11)$$

while

$$\mathcal{I}[\mathbf{A}] = \mathbf{A} \quad . \quad (3.12)$$

We write \mathcal{S} for the fourth-order tensor with the property

$$\mathcal{S}[\mathbf{A}] = \mathbf{A}^T \quad , \quad (3.13)$$

so that

$$\mathcal{S}_{ijmn} = \delta_{in} \delta_{jm} \quad . \quad (3.14)$$

Every isotropic fourth-order tensor \mathcal{K} possesses the representation

$$\mathcal{K} = k_1 \mathbf{1} \otimes \mathbf{1} + k_2 \mathcal{I} + k_3 \mathcal{S} \quad , \quad (3.15)$$

where k_1, k_2, k_3 are scalars.

For a second-order skew-symmetric tensor \mathbf{W} with axial vector \mathbf{w} we have

$$\mathbf{W}\mathbf{c} = \mathbf{w} \times \mathbf{c} \quad (3.16)$$

for every vector \mathbf{c} , with

$$\mathbf{w} = \text{axl}(\mathbf{W}) \quad , \quad \mathbf{W} = \text{Spn}(\mathbf{w}) \quad , \quad (3.17)$$

or equivalently

$$w_i = \frac{1}{2}e_{ijk}W_{kj} \quad , \quad W_{ij} = e_{kji}w_k \quad , \quad (3.18)$$

e_{ijk} being the permutation symbol. To each second-order rotation tensor \mathbf{R} , there exists a second-order skew-symmetric tensor \mathbf{W} , with axial vector \mathbf{w} , so that

$$\mathbf{R} = \exp(\mathbf{W}) = \exp(\text{Spn}(\mathbf{w})) = \mathbf{1} + \mathbf{W} + \frac{\mathbf{W}^2}{2!} + \frac{\mathbf{W}^3}{3!} + \dots \quad (3.19)$$

or

$$\mathbf{R} = \cos(\|\mathbf{w}\|)\mathbf{1} + \frac{\sin(\|\mathbf{w}\|)}{\|\mathbf{w}\|}\text{Spn}(\mathbf{w}) + \frac{1 - \cos(\|\mathbf{w}\|)}{\|\mathbf{w}\|^2}(\mathbf{w} \otimes \mathbf{w}) \quad , \quad (3.20)$$

the latter being known as the Euler-Rodrigues formula.

3.3 Balance Laws

3.3.1 Macro- and microcontinuum

Consider a material body (macroscopic continuum, macroscopic material, macrocontinuum, or overall material body) \mathcal{B} , which occupies the region $\mathcal{R}_{\mathcal{R}}$, with boundary $\partial\mathcal{R}_{\mathcal{R}}$, in the three-dimensional Euclidean point space \mathbf{E} in some reference configuration (which is assumed here to be the undeformed configuration at time $t = 0$). Note that the macrocontinuum here is the same as the overall material in Mindlin's theory [122] and in general different than the macromaterial there. Choosing a fixed point (origin) in \mathbf{E} , we identify each particle (material point) of \mathcal{B} by the position vector \mathbf{X} to the place X in $\mathcal{R}_{\mathcal{R}}$ occupied by the particle considered. We write \mathbf{x} for the position vector to the place x occupied by the same particle in the (current or actual) configuration at time t . In this configuration, the body \mathcal{B} occupies the region \mathcal{R}_t , with boundary $\partial\mathcal{R}_t$, in \mathbf{E} . As usual in classical continuum mechanics, we use the term configuration to denote the map from the material body to the space region or the space region itself. Often we use \mathbf{x} to denote the position vector to a point x , or the point x in \mathbf{E} itself. It is convenient to introduce fixed Cartesian coordinate systems X_i and x_i , $i = 1, 2, 3$, in $\mathcal{R}_{\mathcal{R}}$ and \mathcal{R}_t respectively, inducing the orthonormal bases $\{\mathbf{E}_i\}$ and $\{\mathbf{e}_i\}$. Then $\mathbf{X} = X_i\mathbf{E}_i$ and $\mathbf{x} = x_i\mathbf{e}_i$.

A motion of \mathcal{B} in \mathbf{E} , i.e., a one-parameter family of configurations parameterized by the time t , is a mapping

$$\bar{\mathbf{x}} : (\mathbf{X}, t) \mapsto \mathbf{x} = \bar{\mathbf{x}}(\mathbf{X}, t) \quad , \quad (3.21)$$

which has an inverse $\mathbf{X} = \bar{\mathbf{X}}(\mathbf{x}, t)$ at fixed time t .

The deformation gradient tensor corresponding to Eq. (3.21) is denoted by

$$\mathbf{F} = \mathbf{F}(\mathbf{X}, t) = \frac{\partial \bar{\mathbf{x}}}{\partial \mathbf{X}} = \text{GRAD} \bar{\mathbf{x}} \quad , \quad (3.22)$$

where $\det \mathbf{F} > 0$ is assumed. We distinguish between GRAD and grad, representing the gradient operator with respect to \mathbf{X} and \mathbf{x} , respectively. For later reference, we notice here the nomenclature $\text{div} \mathbf{T} = \frac{\partial T_{ij}}{\partial x_j} \mathbf{e}_i$, for an Eulerian second-order tensor field $\mathbf{T} = \mathbf{T}(\mathbf{x})$. Moreover, we will write $d\mathbf{A} = d\mathbf{A}n_{\mathcal{R}}$

for a material surface element at \mathbf{X} in $\mathcal{R}_{\mathcal{R}}$, the corresponding material surface element in \mathcal{R}_t being $d\mathbf{a} = d\mathbf{a}\mathbf{n}$, where $\mathbf{n}_{\mathcal{R}}$ and \mathbf{n} are the unit normals to the surface elements in $\mathcal{R}_{\mathcal{R}}$ and \mathcal{R}_t , respectively. We denote by V the volume of the body in $\mathcal{R}_{\mathcal{R}}$ and by v the volume of the body in \mathcal{R}_t . If dV is a volume element at \mathbf{X} , then the corresponding volume element at \mathbf{x} is dv , and we have

$$dv = (\det \mathbf{F})dV \quad . \quad (3.23)$$

The right Cauchy-Green deformation tensor \mathbf{C} and the left Cauchy-Green deformation tensor \mathbf{B} are given by

$$\mathbf{C} = \mathbf{F}^T \mathbf{F} = \mathbf{U}^2 \quad , \quad \mathbf{B} = \mathbf{F} \mathbf{F}^T = \mathbf{V}^2 \quad , \quad (3.24)$$

in which \mathbf{U} and \mathbf{V} , called respectively the right and left stretch tensors, are symmetric and positive definite. They appear in the polar decomposition of \mathbf{F} ,

$$\mathbf{F} = \mathbf{R} \mathbf{U} = \mathbf{V} \mathbf{R} \quad , \quad (3.25)$$

where \mathbf{R} represents a proper orthogonal second-order tensor, called the material rotation. We denote by \mathbf{L} the velocity gradient tensor,

$$\mathbf{L} := \text{grad} \dot{\mathbf{x}} = \dot{\mathbf{F}} \mathbf{F}^{-1} = \mathbf{D} + \mathbf{W} \quad , \quad (3.26)$$

$$\mathbf{D} := \frac{1}{2}(\mathbf{L} + \mathbf{L}^T) \quad , \quad \mathbf{W} := \frac{1}{2}(\mathbf{L} - \mathbf{L}^T) \quad , \quad (3.27)$$

where \mathbf{D} is the (macroscopic) deformation rate tensor and \mathbf{W} is called the (macroscopic) material spin tensor.

Next, we attach to each material point of the macroscopic continuum a microcontinuum (microstructure), which serves to model, in the framework of phenomenological continuum mechanics, microphysical (microstructural) properties of the overall material body. The microcontinuum is generally a fictitious (conceptual) one, which may have arbitrary finite dimensions, i.e., the region in E occupied by the microcontinuum at a material point of the macroscopic material must not necessarily be subset of the region occupied by the macroscopic material itself. Let $\mathcal{R}'_{\mathcal{R}}(\mathbf{X})$ denote the region in E , occupied by the microcontinuum at \mathbf{X} in the reference configuration. In the present paper, $\mathcal{R}'_{\mathcal{R}}(\mathbf{X})$ is supposed to be simple connected. As in the theories of Mindlin and Eringen, each material point of the microcontinuum in $\mathcal{R}'_{\mathcal{R}}(\mathbf{X})$ will be identified by a position vector $\mathbf{X} + \mathbf{X}'$ (see Fig. 3.1). The same material point of the microcontinuum will be identified in the actual configuration, at time t , by the position vector $\mathbf{x} + \mathbf{x}'$. At time t , the region occupied by the microcontinuum at \mathbf{x} will be denoted by $\mathcal{R}'_t(\mathbf{x})$.

The motion of the microstructure is described by the map

$$\bar{\mathbf{x}}' : (\mathbf{X}, \mathbf{X}', t) \mapsto \mathbf{x}' = \bar{\mathbf{x}}'(\mathbf{X}, \mathbf{X}', t) \quad , \quad (3.28)$$

which is postulated to possess an inverse $\mathbf{X}' = \bar{\bar{\mathbf{X}}}'(\mathbf{x}, \mathbf{x}', t)$, at fixed t . Microphysically, real materials indicate some kind of patterning with discrete distributed mass. The aim of the microstructure is to offer phenomenologically the possibility to model properties of the patterned material. To this end, we suppose the microcontinuum at \mathbf{X} to be, in some sense, mechanically equivalent to some patterned material neighborhood around the material point \mathbf{X} . The mass in the microcontinuum is assumed to be continuously distributed, so that a mass density $\varrho'(\mathbf{x}, \mathbf{x}', t)$ is assigned to each point in $\mathcal{R}'_t(\mathbf{x})$, the corresponding mass density in $\mathcal{R}'_{\mathcal{R}}(\mathbf{X})$ being $\varrho'_{\mathcal{R}}(\mathbf{X}, \mathbf{X}') \equiv \varrho'(\mathbf{X}, \mathbf{X}', 0)$.

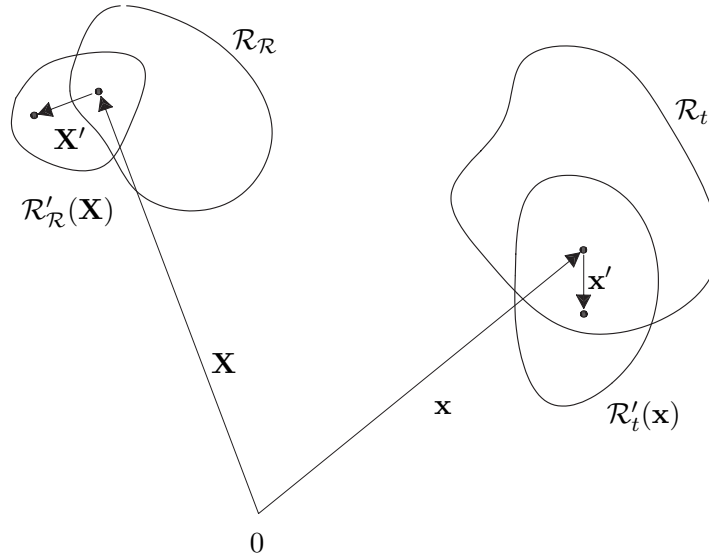

Figure 3.1: The region $\mathcal{R}'_{\mathcal{R}}(\mathbf{X})$ (respectively $\mathcal{R}'_t(\mathbf{x})$) must not necessarily be subset of the region $\mathcal{R}_{\mathcal{R}}$ (respectively \mathcal{R}_t).

A micropolar material is defined to be a material body with a microcontinuum at each point, which behaves like a rigid body. That means, the deformation of the microcontinuum at \mathbf{X} is described by the rotation tensor

$$\bar{\mathbf{R}} = \bar{\mathbf{R}}(\mathbf{X}, t) = \frac{\partial \bar{\mathbf{x}}'}{\partial \bar{\mathbf{X}}'} \quad , \quad \det \bar{\mathbf{R}} = 1 \quad , \quad (3.29)$$

which is referred to as the micropolar rotation. Let $V'(\mathbf{X})$, $v'(\mathbf{x}, t)$ be the volumes of the spaces occupied by the same microcontinuum in the reference and the actual configuration, respectively. In the ensuing analysis we shall often suppress the argument \mathbf{X} in functions $V'(\mathbf{X})$, $\mathcal{R}'_{\mathcal{R}}(\mathbf{X})$, the argument \mathbf{x} in function $\mathcal{R}'_t(\mathbf{x})$, and the arguments \mathbf{x} , t in function $v'(\mathbf{x}, t)$. Since $\det \bar{\mathbf{R}} = 1$, we have

$$v' = V' \quad \text{or} \quad dv' = dV' \quad . \quad (3.30)$$

Moreover, conservation of mass for the microcontinuum is assumed to apply, so that

$$\varrho'(\mathbf{x}, \mathbf{x}', t) = \varrho'_{\mathcal{R}}(\mathbf{X}, \mathbf{X}') \quad . \quad (3.31)$$

Following Eringen [46, p. 24], we call

$$\mathbf{\Omega} := \dot{\bar{\mathbf{R}}}\bar{\mathbf{R}}^T = -\mathbf{\Omega}^T \quad (3.32)$$

the microgyration tensor. The axial vector of the skewsymmetric tensor $\mathbf{\Omega}$ is denoted by $\boldsymbol{\omega}$:

$$\Omega_{ij} = e_{jim}\omega_k \quad . \quad (3.33)$$

Size effects in the response e.g. of elastic materials can be accounted for by assuming the specific free energy function Ψ to depend on $\text{GRAD}\bar{\mathbf{R}} = \frac{\partial \bar{\mathbf{R}}}{\partial X_k} \otimes \mathbf{E}_k$, besides the deformation gradient tensor and the rotation tensor. It can be seen (see, e.g., [67] and [46]) that the principle of material objectivity

is always satisfied if and only if $\Psi = \bar{\Psi}(\bar{\mathbf{U}}, \bar{\mathbf{R}}^T \text{GRAD} \bar{\mathbf{R}})$. It is common in micropolar theories to work with the second-order tensor

$$\tilde{\mathbf{K}} := \tilde{\gamma}_k \otimes \mathbf{E}_k \quad , \quad \tilde{\gamma}_k := \text{axl} \left(\bar{\mathbf{R}}^T \frac{\partial \bar{\mathbf{R}}}{\partial X_k} \right) \quad (3.34)$$

instead of the third-order tensor $\tilde{\mathcal{K}} := \bar{\mathbf{R}}^T \text{GRAD} \bar{\mathbf{R}}$, with $\tilde{\gamma}_k$ being the axial vector of the skew-symmetric tensor $\tilde{\Gamma}_k := \bar{\mathbf{R}}^T \frac{\partial \bar{\mathbf{R}}}{\partial X_k}$. Thus, for micropolar elasticity, the specific free energy function reads

$$\Psi = \tilde{\Psi}(\tilde{\boldsymbol{\epsilon}}, \tilde{\mathbf{K}}) \quad , \quad (3.35)$$

where the micropolar Lagrangean strain tensor $\tilde{\boldsymbol{\epsilon}}$ is given by

$$\tilde{\boldsymbol{\epsilon}} := \bar{\mathbf{U}} - \mathbf{1} = \bar{\mathbf{R}}^T \mathbf{F} - \mathbf{1} \quad . \quad (3.36)$$

Geometrical interpretations for $\tilde{\boldsymbol{\epsilon}}$ and $\tilde{\mathbf{K}}$, on the basis of line elements and so-called directors, are elaborated in [67]. Especially, some scalar differences are introduced there, which may be represented in a form-invariant way with respect to the chosen configuration, whenever strain and curvature tensors are used, which are elements from the same equivalence classes induced by $\tilde{\boldsymbol{\epsilon}}$ and $\tilde{\mathbf{K}}$.

3.3.2 Conservation of mass for the macroscopic continuum

Let $\varrho_{\mathcal{R}}(\mathbf{X})$ be the mass density of the macroscopic continuum in the reference configuration. We suppose $\varrho_{\mathcal{R}}$ to be given by the volume average

$$\varrho_{\mathcal{R}}(\mathbf{X}) = \langle \varrho'_{\mathcal{R}}(\mathbf{X}, \mathbf{X}') \rangle_{\mathcal{R}_{\mathcal{R}}} := \frac{1}{V'} \int_{\mathcal{R}'_{\mathcal{R}}} \varrho'_{\mathcal{R}}(\mathbf{X}, \mathbf{X}') dV' \quad . \quad (3.37)$$

We write $\varrho(\mathbf{x}, t)$ for the mass density of the macroscopic continuum in the actual configuration and require conservation of mass for the macroscopic continuum,

$$\varrho(\mathbf{x}, t) = \frac{\varrho_{\mathcal{R}}(\mathbf{X})}{\det \mathbf{F}(\mathbf{X}, t)} \quad . \quad (3.38)$$

The latter together with Eqs. (3.37), (3.31) and (3.30) yields

$$\varrho(\mathbf{x}, t) = \langle \varrho'(\mathbf{x}, \mathbf{x}', t) \rangle_{\mathcal{R}_t} = \frac{1}{v'} \int_{\mathcal{R}'_t} \chi(\mathbf{x}, t) \varrho'(\mathbf{x}, \mathbf{x}', t) dv' \quad , \quad (3.39)$$

with the weight function χ being defined by

$$\chi(\mathbf{x}, t) := \frac{1}{\det \mathbf{F}} \quad . \quad (3.40)$$

In other words, the mass density of the macroscopic continuum is given by the weighted volume average of the mass density of the microcontinuum. The weight function χ in Eq. (3.39) captures the deformation of the macroscopic continuum. On the other hand, one may think of the mass density of the macroscopic continuum to be defined by Eq. (3.39). Then, as $\varrho'(\mathbf{X}, \mathbf{X}', 0) = \varrho'_{\mathcal{R}}(\mathbf{X}, \mathbf{X}')$, $v'(\mathbf{X}, 0) = V'(\mathbf{X})$, $\mathbf{F}(\mathbf{X}, 0) = \mathbf{1}$, and hence $\chi(\mathbf{X}, 0) = 1$, we see that $\varrho(\mathbf{X}, 0) = \varrho_{\mathcal{R}}(\mathbf{X})$, with $\varrho_{\mathcal{R}}(\mathbf{X})$ given by Eq. (3.37).

3.3.3 Balance laws of momentum and moment of momentum

Taking into account the motion of the microcontinuum, Mindlin [122] elaborated rigorous derivations for the balance laws of momentum and of moment of momentum for continua with "microstructure". Following steps similar to those in Mindlin's approach, but adjusted to the micropolar finite deformation version of the theory adopted here, one may derive the balance of momentum

$$\operatorname{div} \mathbf{T} + \mathbf{b} = \rho \ddot{\mathbf{x}} \quad \text{in } \mathcal{R}_t \quad , \quad (3.41)$$

the balance of moment of momentum

$$\mathbf{t}_T + \operatorname{div} \mathbf{T}_c + \mathbf{b}_c = \rho \dot{\boldsymbol{\sigma}} \quad \text{in } \mathcal{R}_t \quad , \quad (3.42)$$

and appropriate boundary conditions. The proof of this assertion is given in Sect. 3.8. \mathbf{T} is the Cauchy stress tensor, \mathbf{T}_c is the so-called Eulerian couple stress tensor and the vectors \mathbf{t}_T , \mathbf{b} , \mathbf{b}_c , $\boldsymbol{\sigma}$ are explained in Sect. 3.8. Relations (3.41)–(3.42) have been established for the first time by Eringen [45] using another approach.

3.4 The micropolar plasticity model

Multiplicative decomposition of \mathbf{F} into elastic and plastic parts for classical plasticity has been assumed by Lee (see, e.g., [101] and [100]). For micropolar plasticity, multiplicative decompositions of \mathbf{F} and $\bar{\mathbf{R}}$, into elastic and plastic parts, respectively, were postulated by Steinmann [149]:

$$\mathbf{F} = \mathbf{F}_e \mathbf{F}_p \quad , \quad \bar{\mathbf{R}} = \bar{\mathbf{R}}_e \bar{\mathbf{R}}_p \quad . \quad (3.43)$$

Geometrically, \mathbf{F}_p and $\bar{\mathbf{R}}_p$ introduce a so-called plastic intermediate configuration, denoted by \hat{R}_t . Based on Eqs. (3.43), a thermodynamically consistent micropolar plasticity theory, exhibiting isotropic and kinematic hardening effects, has been proposed in [67]. The most relevant constitutive relations of that theory, relative to the plastic intermediate configuration, read as follows:

Kinematics

$$\mathbf{F} = \mathbf{R}\mathbf{U} = \mathbf{V}\mathbf{R} \quad , \quad \mathbf{F}_e = \mathbf{R}_e \mathbf{U}_e = \mathbf{V}_e \mathbf{R}_e \quad , \quad \mathbf{F}_p = \mathbf{R}_p \mathbf{U}_p = \mathbf{V}_p \mathbf{R}_p \quad , \quad (3.44)$$

$$\hat{\mathbf{C}}_e = \mathbf{F}_e^T \mathbf{F}_e \quad , \quad \mathbf{B}_e = \mathbf{F}_e \mathbf{F}_e^T \quad , \quad \hat{\mathbf{B}}_p = \mathbf{F}_p \mathbf{F}_p^T \quad , \quad (3.45)$$

$$\mathbf{F} = \bar{\mathbf{R}}\bar{\mathbf{U}} = \bar{\mathbf{V}}\bar{\mathbf{R}} \quad , \quad \mathbf{F}_e = \bar{\mathbf{R}}_e \bar{\mathbf{U}}_e = \bar{\mathbf{V}}_e \bar{\mathbf{R}}_e \quad , \quad \mathbf{F}_p = \bar{\mathbf{R}}_p \bar{\mathbf{U}}_p = \bar{\mathbf{V}}_p \bar{\mathbf{R}}_p \quad , \quad (3.46)$$

$$\hat{\mathbf{L}}_p = \dot{\mathbf{F}}_p \mathbf{F}_p^{-1} \quad , \quad \hat{\mathbf{D}}_p = \frac{1}{2}(\hat{\mathbf{L}}_p + \hat{\mathbf{L}}_p^T) \quad , \quad \hat{\mathbf{W}}_p = \frac{1}{2}(\hat{\mathbf{L}}_p - \hat{\mathbf{L}}_p^T) \quad , \quad \hat{\boldsymbol{\Omega}}_p = \dot{\bar{\mathbf{R}}}_p \bar{\mathbf{R}}_p^T \quad , \quad (3.47)$$

$$\hat{\boldsymbol{\epsilon}} = \hat{\boldsymbol{\epsilon}}_e + \hat{\boldsymbol{\epsilon}}_p \quad , \quad \hat{\boldsymbol{\epsilon}}_e = \bar{\mathbf{U}}_e - \mathbf{1} \quad , \quad \hat{\boldsymbol{\epsilon}}_p = \mathbf{1} - \bar{\mathbf{V}}_p^{-1} \quad , \quad (3.48)$$

$$\hat{\mathbf{K}} = \hat{\mathbf{K}}_e + \hat{\mathbf{K}}_p = \bar{\mathbf{R}}_p \tilde{\mathbf{K}} \bar{\mathbf{R}}_p^T \quad , \quad \tilde{\mathbf{K}} = \left\{ \operatorname{axl} \left(\bar{\mathbf{R}}^T \frac{\partial \bar{\mathbf{R}}}{\partial X_k} \right) \right\} \otimes \mathbf{E}_k \quad . \quad (3.49)$$

Stress and couple stress tensors

$$\mathbf{S} = (\det \mathbf{F}) \mathbf{T} = \bar{\mathbf{R}}_e \hat{\mathbf{T}} \mathbf{F}_e^T = \mathbf{F}_e \hat{\mathbf{S}} \mathbf{F}_e^T \quad , \quad \hat{\mathbf{P}} = (\mathbf{1} + \hat{\boldsymbol{\epsilon}}_e^T) \hat{\mathbf{T}} = \hat{\mathbf{C}}_e \hat{\mathbf{S}} \quad , \quad (3.50)$$

$$\mathbf{S}_c = (\det \bar{\mathbf{V}}) \mathbf{T}_c \bar{\mathbf{V}}^{T-1} = \bar{\mathbf{R}}_e \hat{\mathbf{T}}_c \bar{\mathbf{R}}_e^T \quad , \quad \hat{\mathbf{P}}_c \equiv \hat{\mathbf{T}}_c \quad . \quad (3.51)$$

Specific free energy

$$\Psi(t) = \Psi_e(t) + \Psi_p(t) \quad , \quad \Psi_p(t) = \Psi_p^{(is)}(t) + \Psi_p^{(kin)}(t) \quad . \quad (3.52)$$

Elasticity law

$$\begin{aligned} \Psi_e &= \hat{\Psi}_e(\hat{\boldsymbol{\epsilon}}_e, \hat{\mathbf{K}}_e) \\ &= \frac{1}{2\varrho\mathcal{R}} \left\{ \lambda(\text{tr}\hat{\boldsymbol{\epsilon}}_e)^2 + (\mu + \alpha)\hat{\boldsymbol{\epsilon}}_e \cdot \hat{\boldsymbol{\epsilon}}_e + (\mu - \alpha)\hat{\boldsymbol{\epsilon}}_e \cdot \hat{\boldsymbol{\epsilon}}_e^T \right. \\ &\quad \left. + \beta(\text{tr}\hat{\mathbf{K}}_e)^2 + (\gamma + \delta)\hat{\mathbf{K}}_e \cdot \hat{\mathbf{K}}_e + (\gamma - \delta)\hat{\mathbf{K}}_e \cdot \hat{\mathbf{K}}_e^T \right\} \quad , \end{aligned} \quad (3.53)$$

$$\hat{\mathbf{T}} = \varrho\mathcal{R} \frac{\partial \hat{\Psi}_e}{\partial \hat{\boldsymbol{\epsilon}}_e} = \lambda(\text{tr}\hat{\boldsymbol{\epsilon}}_e)\mathbf{1} + 2\mu(\hat{\boldsymbol{\epsilon}}_e)_S + 2\alpha(\hat{\boldsymbol{\epsilon}}_e)_A \quad , \quad (3.54)$$

$$\hat{\mathbf{T}}_c = \varrho\mathcal{R} \frac{\partial \hat{\Psi}_e}{\partial \hat{\mathbf{K}}_e} = \beta(\text{tr}\hat{\mathbf{K}}_e)\mathbf{1} + 2\gamma(\hat{\mathbf{K}}_e)_S + 2\delta(\hat{\mathbf{K}}_e)_A \quad . \quad (3.55)$$

Yield function

$$\begin{aligned} f(t) &= \hat{f}(\hat{\mathbf{P}}, \hat{\mathbf{P}}_c, \hat{\boldsymbol{\xi}}, \hat{\boldsymbol{\xi}}_c, k) \\ &= \left\{ (\alpha_1 + \alpha_2)(\hat{\mathbf{P}} - \hat{\boldsymbol{\xi}})^D \cdot (\hat{\mathbf{P}} - \hat{\boldsymbol{\xi}})^D + (\alpha_1 - \alpha_2)(\hat{\mathbf{P}} - \hat{\boldsymbol{\xi}})^D \cdot (\hat{\mathbf{P}}^T - \hat{\boldsymbol{\xi}}^T)^D \right. \\ &\quad \left. + (\alpha_3 + \alpha_4)(\hat{\mathbf{P}}_c - \hat{\boldsymbol{\xi}}_c)^D \cdot (\hat{\mathbf{P}}_c - \hat{\boldsymbol{\xi}}_c)^D + (\alpha_3 - \alpha_4)(\hat{\mathbf{P}}_c - \hat{\boldsymbol{\xi}}_c)^D \cdot (\hat{\mathbf{P}}_c^T - \hat{\boldsymbol{\xi}}_c^T)^D \right\}^{\frac{1}{2}} - k \quad , \\ k &= h + R \quad , \quad h = \text{const.} \quad . \end{aligned} \quad (3.56)$$

Loading criteria

$$f = 0 \quad : \quad \text{yield condition} \quad , \quad L(t) := \left[\dot{f}(t) \right]_{s=\text{const.}} \quad , \quad (3.57)$$

$$\dot{s} \begin{cases} > 0 & \text{if } f = 0 \text{ and } L > 0 \quad (\Leftrightarrow \text{plastic loading}) \quad , \\ = 0 & \text{otherwise} \quad . \end{cases} \quad (3.58)$$

Flow rules

$$\overset{\diamond}{\hat{\boldsymbol{\epsilon}}}_p = \dot{\hat{\boldsymbol{\epsilon}}}_p - \hat{\boldsymbol{\Omega}}_p \hat{\boldsymbol{\epsilon}}_p + \hat{\boldsymbol{\epsilon}}_p \hat{\mathbf{L}}_p \equiv \hat{\mathbf{L}}_p - \hat{\boldsymbol{\Omega}}_p = \frac{\dot{s}}{\zeta} \frac{\partial \hat{f}}{\partial \hat{\mathbf{P}}} = \frac{\dot{s}}{\zeta k} \left\{ 2\alpha_1(\hat{\mathbf{P}} - \hat{\boldsymbol{\xi}})_S^D + 2\alpha_2(\hat{\mathbf{P}} - \hat{\boldsymbol{\xi}})_A^D \right\} \quad , \quad (3.59)$$

$$\overset{\diamond}{\hat{\mathbf{K}}}_p = \dot{\hat{\mathbf{K}}}_p - \hat{\boldsymbol{\Omega}}_p \hat{\mathbf{K}}_p - \hat{\mathbf{K}}_p \hat{\boldsymbol{\Omega}}_p^T = \frac{\dot{s}}{\zeta} \frac{\partial \hat{f}}{\partial \hat{\mathbf{P}}_c} = \frac{\dot{s}}{\zeta k} \left\{ 2\alpha_3(\hat{\mathbf{P}}_c - \hat{\boldsymbol{\xi}}_c)_S^D + 2\alpha_4(\hat{\mathbf{P}}_c - \hat{\boldsymbol{\xi}}_c)_A^D \right\} \quad , \quad (3.60)$$

$$\dot{s} := \sqrt{\overset{\diamond}{\hat{\boldsymbol{\epsilon}}}_p \cdot \overset{\diamond}{\hat{\boldsymbol{\epsilon}}}_p + \overset{\diamond}{\hat{\mathbf{K}}}_p \cdot \overset{\diamond}{\hat{\mathbf{K}}}_p} \quad , \quad (3.61)$$

$$\begin{aligned} \zeta &:= \sqrt{\frac{\partial \hat{f}}{\partial \hat{\mathbf{P}}} \cdot \frac{\partial \hat{f}}{\partial \hat{\mathbf{P}}} + \frac{\partial \hat{f}}{\partial \hat{\mathbf{P}}_c} \cdot \frac{\partial \hat{f}}{\partial \hat{\mathbf{P}}_c}} \\ &= \frac{1}{k} \left\{ \left[2\alpha_1(\hat{\mathbf{P}} - \hat{\boldsymbol{\xi}})_S^D + 2\alpha_2(\hat{\mathbf{P}} - \hat{\boldsymbol{\xi}})_A^D \right] \cdot \left[2\alpha_1(\hat{\mathbf{P}} - \hat{\boldsymbol{\xi}})_S^D + 2\alpha_2(\hat{\mathbf{P}} - \hat{\boldsymbol{\xi}})_A^D \right] \right\} \end{aligned}$$

$$+ \left[2\alpha_3(\hat{\mathbf{P}}_c - \hat{\boldsymbol{\xi}}_c)_S^D + 2\alpha_4(\hat{\mathbf{P}}_c - \hat{\boldsymbol{\xi}}_c)_A^D \right] \cdot \left[2\alpha_3(\hat{\mathbf{P}}_c - \hat{\boldsymbol{\xi}}_c)_S^D + 2\alpha_4(\hat{\mathbf{P}}_c - \hat{\boldsymbol{\xi}}_c)_A^D \right] \Big\}^{\frac{1}{2}} . \quad (3.62)$$

Isotropic hardening

$$\Psi_p^{(is)} = \hat{\Psi}_p^{(is)}(r) = \frac{1}{\varrho\mathcal{R}} \left(\frac{1}{2}\gamma^{(is)}r^2 + R_0r \right) , \quad (3.63)$$

$$R := \varrho\mathcal{R} \frac{\partial \hat{\Psi}_p^{(is)}}{\partial r} = \gamma^{(is)}r + R_0 \quad , \quad R_0 = R|_{s=0} \quad , \quad k_0 := k|_{s=0} = R_0 + h \quad , \quad (3.64)$$

$$\dot{r} = (1 - \beta^{(is)}r) \frac{\dot{s}}{\zeta} \quad , \quad r|_{s=0} = 0 \quad \Leftrightarrow \quad (3.65)$$

$$\dot{R} = [\gamma^{(is)} - \beta^{(is)}(R - R_0)] \frac{\dot{s}}{\zeta} \quad \Leftrightarrow \quad \dot{k} = [\gamma^{(is)} - \beta^{(is)}(k - k_0)] \frac{\dot{s}}{\zeta} . \quad (3.66)$$

Kinematic hardening

$$\begin{aligned} \hat{\boldsymbol{\xi}} & : \text{ back-stress tensor } \quad , \quad \hat{\boldsymbol{\xi}}_c : \text{ back-couple stress tensor } \quad , \\ \Psi_p^{(kin)} & = \hat{\Psi}_p^{(kin)}(\hat{\mathbf{Y}}, \hat{\mathbf{Y}}_c) \end{aligned} \quad (3.67)$$

$$\begin{aligned} & = \frac{1}{2\varrho\mathcal{R}} \left\{ c_1(\text{tr}\hat{\mathbf{Y}})^2 + (c_2 + c_3)\hat{\mathbf{Y}} \cdot \hat{\mathbf{Y}} + (c_2 - c_3)\hat{\mathbf{Y}} \cdot \hat{\mathbf{Y}}^T \right. \\ & \quad \left. + c_4(\text{tr}\hat{\mathbf{Y}}_c)^2 + (c_5 + c_6)\hat{\mathbf{Y}}_c \cdot \hat{\mathbf{Y}}_c + (c_5 - c_6)\hat{\mathbf{Y}}_c \cdot \hat{\mathbf{Y}}_c^T \right\} \quad , \end{aligned} \quad (3.68)$$

$$\hat{\boldsymbol{\xi}} := (\mathbf{1} - \hat{\mathbf{Y}}^T)\hat{\mathbf{Z}} \quad , \quad \hat{\boldsymbol{\xi}}_c \equiv \hat{\mathbf{Z}}_c \quad , \quad (3.69)$$

$$\hat{\mathbf{Z}} := \varrho\mathcal{R} \frac{\partial \hat{\Psi}_p^{(kin)}}{\partial \hat{\mathbf{Y}}} = c_1(\text{tr}\hat{\mathbf{Y}})\mathbf{1} + 2c_2\hat{\mathbf{Y}}_S + 2c_3\hat{\mathbf{Y}}_A \quad , \quad (3.70)$$

$$\hat{\mathbf{Z}}_c := \varrho\mathcal{R} \frac{\partial \hat{\Psi}_p^{(kin)}}{\partial \hat{\mathbf{Y}}_c} = c_4(\text{tr}\hat{\mathbf{Y}})\mathbf{1} + 2c_5(\hat{\mathbf{Y}}_c)_S + 2c_6(\hat{\mathbf{Y}}_c)_A \quad , \quad (3.71)$$

$$\hat{\mathbf{Y}} := \hat{\mathbf{Y}} - \hat{\boldsymbol{\Omega}}_p\hat{\mathbf{Y}} + \hat{\mathbf{Y}}\hat{\mathbf{L}}_p = \hat{\boldsymbol{\epsilon}}_p - \dot{s}(2b_1\hat{\mathbf{Z}}_S + 2b_2\hat{\mathbf{Z}}_A) \quad , \quad (3.72)$$

$$\hat{\mathbf{Y}}_c := \hat{\mathbf{Y}}_c - \hat{\boldsymbol{\Omega}}_p\hat{\mathbf{Y}}_c - \hat{\mathbf{Y}}_c\hat{\boldsymbol{\Omega}}_p^T = \hat{\mathbf{K}}_p - \dot{s}(2b_{c1}(\hat{\mathbf{Z}}_c)_S + 2b_{c2}(\hat{\mathbf{Z}}_c)_A) \quad . \quad (3.73)$$

In these equations, plastic incompressibility is assumed to apply, so that $\det \mathbf{F}_p = 1$ or $\text{tr} \hat{\mathbf{L}}_p = 0$. While Eqs. (3.44) represent polar decompositions, this is not the case for Eqs. (3.46). It is important to notice that the second-order tensors $\bar{\mathbf{U}}, \bar{\mathbf{V}}, \bar{\mathbf{U}}_e, \bar{\mathbf{V}}_e, \bar{\mathbf{U}}_p, \bar{\mathbf{V}}_p$ do not represent symmetric tensors generally. The micropolar strains $\hat{\boldsymbol{\epsilon}}, \hat{\boldsymbol{\epsilon}}_e, \hat{\boldsymbol{\epsilon}}_p$ and the so-called curvatures $\hat{\mathbf{K}}, \hat{\mathbf{K}}_e, \hat{\mathbf{K}}_p$ are second-order tensors, which are generally non-symmetric. It is worth remarking that the definition of $\hat{\mathbf{K}}_p$ in [67] involves the gradient operator and therefore $\hat{\mathbf{K}}_p$ has to satisfy some compatibility conditions.

However, one can motivate geometrically the additive decomposition of $\hat{\mathbf{K}}$ as done in [67], and then require the validity of this for more general cases, where $\hat{\mathbf{K}}_p$ is only an arbitrary map, not necessarily related to some gradient operators. This corresponds to the fact that \mathbf{F}_p does not represent a gradient tensor generally, and confirms a proposal made by Steinmann [149]. Thus, all relations in the constitutive theory developed in [67] remain valid. \mathbf{T} and \mathbf{T}_c are the Cauchy stress tensor and the Eulerian

couple stress tensor, respectively; they enter into the local equations of momentum and of moment of momentum (see Eqs. (3.41) and (3.42)).

$\hat{\mathbf{P}}$ and $\hat{\mathbf{P}}_c$ denote so-called Mandel stress and Mandel couple stress tensors, respectively. The specific free energy Ψ in Eq. (3.52) is composed additively of parts responsible for elasticity, isotropic and kinematic hardening. Further, Ψ is stipulated to be an isotropic tensor function of its arguments. Following Eringen [46, Sect. 5], we assume Ψ_e to be given by the quadratic function (3.53). The yield function in Eq. (3.56) represents a finite deformation counterpart of a yield function for small deformations proposed by de Borst [11]. The flow rules are associated normality rules, derived as sufficient conditions for the validity of Il'iusin's postulate extended to micropolar materials. Isotropic hardening is governed by the equations summarized in (3.63)–(3.66). Such forms of isotropic hardening rules are intensively investigated for classical plasticity by Chaboche [19, 20]. It is pointed out that this isotropic hardening model captures effects of micropolar strains and curvatures in a unified manner.

In fact, $\dot{\gamma}$ in Eq. (3.65) depends on \dot{s} which in turn is a function of both $\hat{\hat{\boldsymbol{\epsilon}}}_p$ and $\hat{\hat{\mathbf{K}}}_p$ (see Eq. (3.61)). Of course, one may regard isotropic hardening rules which are additively composed of two parts, accounting for micropolar strains and curvatures separately. However, such possibilities will not affect the goals of the paper essentially. Kinematic hardening is modelled by Eqs. (3.67)–(3.73), with $\hat{\boldsymbol{\xi}}$ and $\hat{\boldsymbol{\xi}}_c$ being back-stress and back-couple stress tensors of Mandel type, respectively. (Classical hardening rules on the basis of Mandel back-stress tensors have been introduced for the first time in [157].) The evolution equations (3.72) and (3.73) correspond to the well-known Armstrong-Frederick kinematic hardening rule in classical, small deformation plasticity. Finally, the quantities $\mu, \lambda, \alpha, \beta, \gamma, \delta, \alpha_1\text{--}\alpha_4, h, \beta^{(is)}, \gamma^{(is)}, R_0, c_1\text{--}c_6, b_1, b_2, b_{c1}, b_{c2}$ are material parameters, which have to be chosen appropriately.

3.5 Classical limit of micropolar elasticity

Before going to establish classical limits for the micropolar plasticity theory presented in the last section, it is convenient to discuss preparatory the case of isotropic micropolar elasticity. The latter is defined by the field equations (3.41) and (3.42), an isotropic specific free energy function (3.35) and the elasticity laws (3.170) and (3.171) (see Sect. 3.8.4).

Classical isotropic elasticity is characterized by a symmetric Cauchy stress tensor \mathbf{T} , or equivalently by a symmetric weighted Cauchy stress tensor \mathbf{S} , and vanishing couple stress tensor \mathbf{T}_c , and therefore vanishing $\tilde{\mathbf{T}}_c$ (see Eq. (3.171)). The first Piola Kirchhoff stress tensor \mathbf{S}_R and the Biot stress tensor \mathbf{S}_B are defined (cf. Ogden [134, Sect. 3.5.2]) by

$$\mathbf{S}_R := \mathbf{S}\mathbf{F}^{T-1} \quad , \quad \mathbf{S}_B := \mathbf{R}^T \mathbf{S}_R = (\mathbf{R}^T \mathbf{S} \mathbf{R}) \mathbf{U}^{-1} \quad , \quad (3.74)$$

so that

$$\mathbf{S}_B \mathbf{U} = \mathbf{R}^T \mathbf{S} \mathbf{R} = \text{sym.} \quad . \quad (3.75)$$

Moreover, there exists a specific free energy function $h = \hat{h}(\mathbf{F})$, which, because of the principle of material objectivity, cannot depend arbitrary on \mathbf{F} , but it is restricted to

$$h = \hat{h}(\mathbf{F}) = \tilde{h}(\mathbf{U}) \quad . \quad (3.76)$$

In the case of isotropy, \tilde{h} is subjected to

$$\tilde{h}(\mathbf{U}) = \tilde{h}(\mathbf{Q}\mathbf{U}\mathbf{Q}^T) \quad , \quad (3.77)$$

where \mathbf{Q} is an arbitrary rotation. Since \mathbf{S}_R is work conjugate to \mathbf{F} , we have $\dot{h} = \frac{\partial \hat{h}}{\partial \mathbf{F}} \cdot \dot{\mathbf{F}} = \frac{1}{\varrho \mathcal{R}} \mathbf{S}_R \cdot \dot{\mathbf{F}}$, and hence $\mathbf{S}_R = \varrho \mathcal{R} \frac{\partial \hat{h}}{\partial \mathbf{F}}$. On the other hand,

$$\mathbf{S}_R \cdot \dot{\mathbf{F}} = \mathbf{S}_B \mathbf{U} \cdot \mathbf{R}^T \dot{\mathbf{R}} + \mathbf{S}_B \cdot \dot{\mathbf{U}} \quad , \quad (3.78)$$

or, in view of the fact that $\mathbf{R}^T \dot{\mathbf{R}}$ is skew symmetric and $\mathbf{S}_B \mathbf{U}$ is symmetric,

$$\mathbf{S}_R \cdot \dot{\mathbf{F}} = \mathbf{S}_B \cdot \dot{\mathbf{U}} \equiv (\mathbf{S}_B)_S \cdot \dot{\mathbf{U}} \quad . \quad (3.79)$$

Thus,

$$\dot{h} = \frac{\partial \tilde{h}}{\partial \mathbf{U}} \cdot \dot{\mathbf{U}} = \frac{1}{\varrho \mathcal{R}} (\mathbf{S}_B)_S \cdot \dot{\mathbf{U}} \quad (3.80)$$

and therefore

$$(\mathbf{S}_B)_S = \varrho \mathcal{R} \frac{\partial \tilde{h}}{\partial \mathbf{U}} \quad . \quad (3.81)$$

Consequently, the elasticity tensor $\mathbf{C} := \varrho \mathcal{R} \frac{\partial^2 \tilde{h}}{\partial \mathbf{U} \partial \mathbf{U}}$ possesses the symmetry properties

$$\mathcal{C}_{ijkl} = \mathcal{C}_{jikl} = \mathcal{C}_{ijlk} = \mathcal{C}_{klij} \quad . \quad (3.82)$$

It is perhaps of interest to notice that isotropy implies that the Cauchy stress tensor may be represented as a function of \mathbf{V} , e.g., of the form

$$\mathbf{S} = \alpha_0 \mathbf{1} + \alpha_1 \mathbf{V} + \alpha_2 \mathbf{V}^2 \quad , \quad (3.83)$$

where $\alpha_0, \alpha_1, \alpha_2$ are invariants of \mathbf{V} . Then

$$\mathbf{S}_B = (\mathbf{R}^T \mathbf{S} \mathbf{R}) \mathbf{U}^{-1} = \alpha_0 \mathbf{U}^{-1} + \alpha_1 \mathbf{1} + \alpha_2 \mathbf{U} \quad , \quad (3.84)$$

which means that \mathbf{S}_B is symmetric, $\mathbf{S}_B \equiv (\mathbf{S}_B)_S$.

Returning to the micropolar elastic material, we define the first Piola Kirchhoff stress tensor \mathbf{S}_R and a Biot stress tensor \mathbf{S}_B as above by $\mathbf{S}_R := \mathbf{S} \mathbf{F}^{T-1}$ and $\mathbf{S}_B := \mathbf{R}^T \mathbf{S}_R = (\mathbf{R}^T \mathbf{S} \mathbf{R}) \mathbf{U}^{-1}$. Then, in view of

$$\tilde{\mathbf{T}} = \bar{\mathbf{R}}^T \mathbf{S} \mathbf{F}^{T-1} \quad (3.85)$$

(cf. Eq. (3.170)), we conclude that

$$\mathbf{S}_B = \mathbf{q}^T \tilde{\mathbf{T}} = (\mathbf{R}^T \mathbf{S} \mathbf{R}) \mathbf{U}^{-1} \quad , \quad (3.86)$$

where

$$\bar{\mathbf{U}} = \mathbf{q} \mathbf{U} \quad , \quad \mathbf{q} := \bar{\mathbf{R}}^T \mathbf{R} \quad . \quad (3.87)$$

The first equation in (3.87) represents the polar decomposition of $\bar{\mathbf{U}}$ with \mathbf{q} and \mathbf{U} being rotation and symmetric positive definite second-order tensors, respectively.

Now, let $\mathbf{u} = (m_1, \dots, m_n)$ be the array of material parameters, with $m_1, \dots, m_p, p < n$, occurring in terms involving the curvature tensor, the remaining being related to terms involving the micropolar

strain tensor only. We denote by $\mathbf{u}_{cl} = (m'_1, \dots, m'_n)$ an array of values with m'_1, \dots, m'_p vanishing. We shall now discuss conditions which have to hold in order for a classical limiting elasticity law to arise when $\mathbf{u} \rightarrow \mathbf{u}_{cl}$.

Concentrating on isotropic elasticity, we assume that as \mathbf{u} approaches \mathbf{u}_{cl} , the free energy function $\tilde{\Psi}$ converges uniformly against $\Psi(t) = \tilde{\Psi}(\tilde{\boldsymbol{\epsilon}})$, so that the following apply:

$$\lim_{\mathbf{u} \rightarrow \mathbf{u}_{cl}} \tilde{\Psi} = \tilde{\Psi}(\tilde{\boldsymbol{\epsilon}}) \quad , \quad (3.88)$$

$$\lim_{\mathbf{u} \rightarrow \mathbf{u}_{cl}} \tilde{\mathbf{T}}_c = \varrho_{\mathcal{R}} \lim_{\mathbf{u} \rightarrow \mathbf{u}_{cl}} \frac{\partial \tilde{\Psi}}{\partial \tilde{\mathbf{K}}} = \mathbf{0} \quad , \quad (3.89)$$

$$\lim_{\mathbf{u} \rightarrow \mathbf{u}_{cl}} \frac{\partial \tilde{\Psi}}{\partial \tilde{\boldsymbol{\epsilon}}} = \frac{\partial \tilde{\Psi}}{\partial \tilde{\boldsymbol{\epsilon}}} \quad . \quad (3.90)$$

In other words, in the limit $\mathbf{u} \rightarrow \mathbf{u}_{cl}$ the couple stress tensor \mathbf{T}_c will vanish, and Eq. (3.170) furnishes

$$\tilde{\mathbf{T}} = \varrho_{\mathcal{R}} \frac{\partial \tilde{\Psi}}{\partial \tilde{\boldsymbol{\epsilon}}} = (\bar{\mathbf{R}}^T \mathbf{S} \bar{\mathbf{R}}) \bar{\mathbf{U}}^{T-1} \quad . \quad (3.91)$$

Consequently,

$$(\tilde{\mathbf{T}} \bar{\mathbf{U}}^T)_S = \varrho_{\mathcal{R}} \left(\frac{\partial \tilde{\Psi}}{\partial \tilde{\boldsymbol{\epsilon}}} \bar{\mathbf{U}}^T \right)_S = \bar{\mathbf{R}}^T \mathbf{S}_S \bar{\mathbf{R}} \quad , \quad (3.92)$$

$$(\tilde{\mathbf{T}} \bar{\mathbf{U}}^T)_A = \varrho_{\mathcal{R}} \left(\frac{\partial \tilde{\Psi}}{\partial \tilde{\boldsymbol{\epsilon}}} \bar{\mathbf{U}}^T \right)_A = \bar{\mathbf{R}}^T \mathbf{S}_A \bar{\mathbf{R}} \quad , \quad (3.93)$$

from which follows that

$$\mathbf{S}_A = \mathbf{0} \quad \Leftrightarrow \quad \tilde{\mathbf{T}} \bar{\mathbf{U}}^T = \bar{\mathbf{U}} \tilde{\mathbf{T}}^T \quad . \quad (3.94)$$

Proceeding to find out conditions imposing \mathbf{S} to be symmetric, we assume the couple body forces \mathbf{b}_c to vanish. It follows from Eq. (3.42) that \mathbf{S} will always be symmetric, and hence $\mathbf{t}_T \equiv \mathbf{0}$, if and only if $\boldsymbol{\sigma} \equiv \text{const.}$. For arbitrary time functions $\boldsymbol{\omega}$ (see Eq. (3.167)), latter may be satisfied if and only if $\mathbf{j} = \mathbf{0}$, which is equivalent to $\boldsymbol{\theta} = \frac{1}{2}(\text{tr} \mathbf{j}) \mathbf{1} - \mathbf{j} = \mathbf{0}$ (cf. Eringen [46, p. 33]). Necessary and sufficient condition for this equation is that the microcontinuum, as adopted here, must vanish, or in other words $\mathbf{R}'_t(\mathbf{x})$ has to shrink to the point $\mathbf{x}' = \mathbf{0}$. This follows from the mean value theorem for integrals and the fact that $\mathbf{x}' \otimes \mathbf{x}'$ in Eqs. (3.151) or (3.162) is positive semi-definite, for all \mathbf{x}' with $\mathbf{x} + \mathbf{x}' \in \mathbf{R}'_t(\mathbf{x})$. Thus, the symmetry of \mathbf{S} is equivalent to vanishing microcontinuum.

Suppose now $\boldsymbol{\theta} = \mathbf{0}$, so that $\mathbf{S}_A = \mathbf{0}$. In order to discuss the symmetry of the stress tensor \mathbf{S} in the context of constitutive relations, we recall that classical isotropic elasticity is characterized by a free energy function of the form (3.77). Thus, we seek for conditions implying

$$\tilde{\Psi}(\bar{\mathbf{U}}) := \tilde{\Psi}(\tilde{\boldsymbol{\epsilon}}) = \tilde{h}(\mathbf{U}) \quad (3.95)$$

or

$$\tilde{\Psi}(\mathbf{qU}) = \tilde{h}(\mathbf{U}) \quad . \quad (3.96)$$

For every symmetric, positive definite tensor \mathbf{U} , the latter is an equation for \mathbf{q} , and therefore for $\bar{\mathbf{R}}$, whenever \mathbf{R} is known.

Let $\mathbf{q} = \mathbf{f}(\mathbf{U})$ be any solution of this equation. When changing the reference configuration from $\mathcal{R}_{\mathcal{R}}$ to $\mathcal{R}_{\mathcal{R}}^*$ by an arbitrary rotation \mathbf{Q} , the deformation gradient tensor \mathbf{F} changes to \mathbf{F}^* ,

$$\mathbf{F}^* = \mathbf{F}\mathbf{Q}^T = \mathbf{R}^*\mathbf{U}^* = \bar{\mathbf{R}}^*\bar{\mathbf{U}}^* \quad , \quad (3.97)$$

with

$$\mathbf{R}^* = \mathbf{R}\mathbf{Q}^T \quad , \quad \mathbf{U}^* = \mathbf{Q}\mathbf{U}\mathbf{Q}^T \quad , \quad \bar{\mathbf{R}}^* = \bar{\mathbf{R}}\mathbf{Q}^T \quad , \quad \bar{\mathbf{U}}^* = \mathbf{Q}\bar{\mathbf{U}}\mathbf{Q}^T \quad (3.98)$$

and

$$\mathbf{q}^* = \bar{\mathbf{R}}^{*T}\mathbf{R}^* = \mathbf{Q}\mathbf{q}\mathbf{Q}^T \quad . \quad (3.99)$$

Because of isotropy, we have $\check{\Psi}(\mathbf{q}^*\mathbf{U}^*) = \check{\Psi}(\mathbf{q}\mathbf{U}) = \check{h}(\mathbf{U}^*) = \check{h}(\mathbf{U})$ and therefore $\mathbf{q}^* = \mathbf{Q}\mathbf{f}(\mathbf{U})\mathbf{Q}^T = \mathbf{f}(\mathbf{U}^*)$ will be solution of the equation $\check{\Psi}(\mathbf{q}^*\mathbf{U}^*) = \check{h}(\mathbf{U}^*)$. That means, $\mathbf{f}(\cdot)$ must be an isotropic tensor function of the symmetric second-order tensor \mathbf{U} ,

$$\mathbf{Q}\mathbf{f}(\mathbf{U})\mathbf{Q}^T = \mathbf{f}(\mathbf{Q}\mathbf{U}\mathbf{Q}^T) \quad . \quad (3.100)$$

It follows that \mathbf{q} has to be also symmetric, because every isotropic tensor-valued function of a symmetric tensor is also symmetric. Hence, \mathbf{q} must indicate the properties $\mathbf{q} = \mathbf{q}^T = \mathbf{q}^{-1}$, which can be fulfilled if and only if $\mathbf{q} \equiv \mathbf{1}$ or $\bar{\mathbf{R}} \equiv \mathbf{R}$. But as $\mathbf{u} \rightarrow \mathbf{u}_{cl}$ and $\bar{\mathbf{R}} = \mathbf{R}$ (or $\bar{\mathbf{U}} = \mathbf{U}$), $\tilde{\mathbf{T}}$ will be reduced to the classical Biot stress tensor, and consequently, $\tilde{\mathbf{T}}$ will be coaxial to \mathbf{U} so that $\mathbf{T}\mathbf{U} = \mathbf{U}\tilde{\mathbf{T}}$, consistent with $\mathbf{S}_A = \mathbf{0}$ in Eq. (3.94). The mathematical interpretation of this result is that in the limiting case there exist no more constitutive and field equations for $\bar{\mathbf{R}}$ and $\bar{\mathbf{R}}$ has to be determined from the solution $\mathbf{q} = \mathbf{f}(\mathbf{U})$. This implies for isotropy the unique solution $\bar{\mathbf{R}} \equiv \mathbf{R}$.

Summarizing, classical isotropic elasticity will be the result whenever $\mathcal{R}'_t(\mathbf{x})$ shrinks to a point, $\mathbf{b}_c = \mathbf{0}$, $\bar{\mathbf{R}} = \mathbf{R}$ (or $\bar{\mathbf{U}} = \mathbf{U}$) and $\mathbf{u} \rightarrow \mathbf{u}_{cl}$ so that $\tilde{\mathbf{T}} \rightarrow (\mathbf{S}_B)_S = \mathbf{S}_B$.

Clearly, if it is desired that the elasticity tensor of the limiting material $\tilde{\mathcal{C}}$ is derivable from the elasticity tensor of the micropolar material, then the limiting process $\mathbf{u} \rightarrow \mathbf{u}_{cl}$ has to take place in such a way that $\tilde{\mathcal{C}}$ indicates the properties

$$\tilde{\mathcal{C}} := \lim_{\mathbf{u} \rightarrow \mathbf{u}_{cl}} \varrho_{\mathcal{R}} \left. \frac{\partial^2 \check{\Psi}}{\partial \tilde{\boldsymbol{\epsilon}} \partial \tilde{\boldsymbol{\epsilon}}} \right|_{\bar{\mathbf{U}} = \mathbf{U}} \equiv \varrho_{\mathcal{R}} \left. \frac{\partial^2 \check{\Psi}}{\partial \tilde{\boldsymbol{\epsilon}} \partial \tilde{\boldsymbol{\epsilon}}} \right|_{\bar{\mathbf{U}} = \mathbf{U}} \quad (3.101)$$

and $\tilde{\mathcal{C}}$ satisfies (3.82). Otherwise, if $\tilde{\mathcal{C}}$ is defined by $\tilde{\mathcal{C}} = \varrho_{\mathcal{R}} \frac{\partial^2 \check{h}}{\partial \bar{\mathbf{U}} \partial \bar{\mathbf{U}}}$, relations (3.82) will be satisfied trivially. To discuss this point in more details, we confine ourself on the free energy function in Eq. (3.53), but for the pure elastic case:

$$\Psi = \check{\Psi}(\tilde{\boldsymbol{\epsilon}}, \tilde{\mathbf{K}}) = \frac{1}{2\varrho_{\mathcal{R}}} \left\{ \lambda(\text{tr}\tilde{\boldsymbol{\epsilon}})^2 + (\mu + \alpha)\tilde{\boldsymbol{\epsilon}} \cdot \tilde{\boldsymbol{\epsilon}} + (\mu - \alpha)\tilde{\boldsymbol{\epsilon}} \cdot \tilde{\boldsymbol{\epsilon}}^T + \beta(\text{tr}\tilde{\mathbf{K}})^2 + (\gamma + \delta)\tilde{\mathbf{K}} \cdot \tilde{\mathbf{K}} + (\gamma - \delta)\tilde{\mathbf{K}} \cdot \tilde{\mathbf{K}}^T \right\} \quad . \quad (3.102)$$

For $\beta, \gamma, \delta \rightarrow 0$ we have

$$\tilde{\Psi}(\tilde{\boldsymbol{\epsilon}}) = \lim_{\beta, \gamma, \delta \rightarrow 0} \check{\Psi}(\tilde{\boldsymbol{\epsilon}}, \tilde{\mathbf{K}}) = \frac{1}{2\varrho_{\mathcal{R}}} \left\{ \lambda(\text{tr}\tilde{\boldsymbol{\epsilon}})^2 + (\mu + \alpha)\tilde{\boldsymbol{\epsilon}} \cdot \tilde{\boldsymbol{\epsilon}} + (\mu - \alpha)\tilde{\boldsymbol{\epsilon}} \cdot \tilde{\boldsymbol{\epsilon}}^T \right\} \quad , \quad (3.103)$$

$$\tilde{\Psi}(\tilde{\boldsymbol{\epsilon}} = \mathbf{U} - \mathbf{1}) = \tilde{h}(\mathbf{U}) = \frac{1}{2\varrho_{\mathcal{R}}} \{ \lambda [\text{tr}(\mathbf{U} - \mathbf{1})]^2 + 2\mu(\mathbf{U} - \mathbf{1}) \cdot (\mathbf{U} - \mathbf{1}) \} \quad , \quad (3.104)$$

$$\frac{\partial^2 \tilde{\Psi}}{\partial \tilde{\boldsymbol{\epsilon}}_{ij} \partial \tilde{\boldsymbol{\epsilon}}_{mn}} = \frac{1}{\varrho_{\mathcal{R}}} \{ \lambda \delta_{ij} \delta_{mn} + \mu (\delta_{im} \delta_{jn} + \delta_{jm} \delta_{in}) + \alpha (\delta_{im} \delta_{jn} - \delta_{jm} \delta_{in}) \} \quad . \quad (3.105)$$

If one defines $\tilde{\mathcal{C}}$ by

$$\tilde{\mathcal{C}} := \varrho_{\mathcal{R}} \left. \frac{\partial^2 \tilde{\Psi}}{\partial \tilde{\boldsymbol{\epsilon}} \partial \tilde{\boldsymbol{\epsilon}}} \right|_{\tilde{\boldsymbol{\epsilon}} = \mathbf{U} - \mathbf{1}} \quad , \quad (3.106)$$

then, in view of Eq. (3.105), $\tilde{\mathcal{C}}$ will fulfill relations (3.82) if and only if $\alpha = 0$. Thus, for classical elasticity the conditions $\alpha, \beta, \gamma, \delta \rightarrow 0$ will be required. If, however, $\tilde{\mathcal{C}}$ is defined by

$$\tilde{\mathcal{C}} := \varrho_{\mathcal{R}} \frac{\partial^2 \tilde{h}}{\partial \mathbf{U} \partial \mathbf{U}} \quad , \quad (3.107)$$

then relations (3.82) will be satisfied trivially and α may be arbitrary.

3.6 Classical limit of the micropolar plasticity model

3.6.1 Elasticity law – flow rule – additive decomposition of strain

Generalizing the results of Sect. 3.5, we suppose $\mathbf{R}'_t(\mathbf{x})$ to be vanishing, $\mathbf{b}_c = \mathbf{0}$, $\bar{\mathbf{R}}_e = \mathbf{R}_e$, and $\beta, \gamma, \delta \rightarrow 0$, so that

$$\Psi_e = \frac{1}{2\varrho_{\mathcal{R}}} \{ \lambda (\text{tr}(\mathbf{U}_e - \mathbf{1}))^2 + 2\mu(\mathbf{U}_e - \mathbf{1}) \cdot (\mathbf{U}_e - \mathbf{1}) \} \quad , \quad (3.108)$$

$$\hat{\mathbf{S}}_B = (\hat{\mathbf{S}}_B)_S = \hat{\mathbf{T}}|_{\bar{\mathbf{U}}_e = \mathbf{U}_e} = \lambda \{ \text{tr}(\mathbf{U}_e - \mathbf{1}) \} \mathbf{1} + 2\mu(\mathbf{U}_e - \mathbf{1}) = \mathbf{R}_e^T \mathbf{S} \mathbf{F}_e^{T-1} \quad . \quad (3.109)$$

It is worth remarking that generally it is not correct to also set $\bar{\mathbf{R}}_p = \mathbf{R}_p$ and therefore $\bar{\mathbf{R}} = \mathbf{R}$. In fact, because of $\mathbf{F} = \mathbf{F}_e \mathbf{F}_p$, $\mathbf{R} = \mathbf{R}_e \mathbf{R}_p$, we would have $\mathbf{U} = \mathbf{R}_p^T \mathbf{U}_e \mathbf{V}_p \mathbf{R}_p$ and hence $\mathbf{U}_e \mathbf{V}_p = \mathbf{V}_p \mathbf{U}_e$. That means, \mathbf{U}_e and \mathbf{V}_p would always possess the same principal axes, which cannot generally be true.

It is convenient to introduce the Second-Piola-Kirchhoff stress tensor $\hat{\mathbf{S}}$, with respect to the plastic intermediate configuration,

$$\hat{\mathbf{S}} = \mathbf{F}_e^{-1} \mathbf{S} \mathbf{F}_e^{T-1} \quad , \quad (3.110)$$

so that the Mandel stress tensor $\hat{\mathbf{P}}$ becomes (cf. [157])

$$\hat{\mathbf{P}} := \hat{\mathbf{C}}_e \hat{\mathbf{S}} = (\mathbf{1} + 2\hat{\mathbf{\Gamma}}_e) \hat{\mathbf{S}} \quad , \quad (3.111)$$

where

$$\hat{\mathbf{\Gamma}}_e = \frac{1}{2} (\hat{\mathbf{C}}_e - \mathbf{1}) \quad . \quad (3.112)$$

In the case of isotropy, assumed here, $\hat{\mathbf{S}}$ and $\hat{\mathbf{\Gamma}}_e$ possess the same principal axes, so that $\hat{\mathbf{\Gamma}}_e \hat{\mathbf{S}}$ is commutative and the Mandel stress tensor becomes symmetric.

Commonly in metal plasticity small elastic strains are assumed. We define by

$$\epsilon_e := \sup_{\mathbf{x} \in \mathcal{R}_{\mathcal{R}}, t \geq 0} \{ \|\mathbf{U}_e - \mathbf{1}\| \} \quad (3.113)$$

a measure for the smallness of elastic strains. Then

$$\mathbf{U}_e = \mathbf{1} + \mathcal{O}(\epsilon_e) \quad , \quad \mathbf{V}_e = \mathbf{1} + \mathcal{O}(\epsilon_e) \quad , \quad \mathbf{F}_e = \mathbf{R}_e + \mathcal{O}(\epsilon_e) \quad , \quad (3.114)$$

where \mathcal{O} denotes the Landau symbol. These allow to establish the approximations

$$\hat{\mathbf{\Gamma}}_e \approx \mathbf{U}_e - \mathbf{1} \quad , \quad \hat{\mathbf{S}} \approx \hat{\mathbf{S}}_B \quad , \quad (3.115)$$

and hence

$$\hat{\mathbf{S}} \approx \lambda(\text{tr} \hat{\mathbf{\Gamma}}_e) \mathbf{1} + 2\mu \hat{\mathbf{\Gamma}}_e \quad . \quad (3.116)$$

In order to obtain classical plasticity with von Mises yield function (cf. [157]), keeping in mind that in the case of elastic isotropy $\hat{\mathbf{P}}$ is symmetric, we set $\alpha_2 = \alpha_3 = \alpha_4 = 0$ and $\alpha_1 = \frac{3}{4}$ in Eq. (3.56) to obtain

$$f = \hat{f}(\hat{\mathbf{P}}, \hat{\boldsymbol{\xi}}, k) = \sqrt{\frac{3}{2}(\hat{\mathbf{P}} - \hat{\boldsymbol{\xi}})_S^D \cdot (\hat{\mathbf{P}} - \hat{\boldsymbol{\xi}})_S^D} - k \quad . \quad (3.117)$$

It follows from Eqs. (3.59)–(3.62) that

$$\hat{\mathbf{D}}_p = \dot{s} \frac{\partial \hat{f}}{\partial \hat{\mathbf{P}}} = \frac{3}{2k} \dot{s} (\hat{\mathbf{P}} - \hat{\boldsymbol{\xi}})_S^D \equiv \frac{3}{2k} \dot{s} (\hat{\mathbf{P}} - \hat{\boldsymbol{\xi}}_S)^D \quad , \quad (3.118)$$

$$\hat{\mathbf{W}}_p = \hat{\boldsymbol{\Omega}}_p \quad , \quad (3.119)$$

$$\hat{\mathbf{K}}_p = \mathbf{0} \quad , \quad (3.120)$$

where now \dot{s} is defined classically through

$$\dot{s} = \sqrt{\frac{2}{3} \hat{\mathbf{D}}_p \cdot \hat{\mathbf{D}}_p} \quad . \quad (3.121)$$

According to Eq. (3.119), the material plastic spin $\hat{\mathbf{W}}_p$ and the micropolar plastic (microgyration) spin $\hat{\boldsymbol{\Omega}}_p$ are equal, but undetermined. Consequently, $\hat{\mathbf{R}}_p$ will be undetermined too. Now, it is convenient to interpret $\hat{\mathbf{D}}_p$ as Oldroyd time derivative of $\hat{\mathbf{\Gamma}}_p$ (see also [157]),

$$\hat{\mathbf{D}}_p = \dot{\hat{\mathbf{\Gamma}}}_p + \hat{\mathbf{L}}_p^T \hat{\mathbf{\Gamma}}_p + \hat{\mathbf{\Gamma}}_p \hat{\mathbf{L}}_p \quad , \quad \hat{\mathbf{\Gamma}}_p := \frac{1}{2}(\mathbf{1} - \hat{\mathbf{B}}_p^{-1}) \quad . \quad (3.122)$$

This way, the resulting model may be formulated by means of the strain tensors $\hat{\mathbf{\Gamma}}_e, \hat{\mathbf{\Gamma}}_p$, and we have

$$\hat{\mathbf{\Gamma}} := \mathbf{F}_p^T \mathbf{E} \mathbf{F}_p = \hat{\mathbf{\Gamma}}_e + \hat{\mathbf{\Gamma}}_p \quad , \quad \mathbf{E} := \frac{1}{2}(\mathbf{F}^T \mathbf{F} - \mathbf{1}) \quad . \quad (3.123)$$

3.6.2 Hardening rules

To complete the derivation of the limiting classical model the rules for isotropic and kinematic hardening remain still to be given. It is a straightforward matter to verify from Eqs. (3.63)–(3.66) that isotropic hardening essentially maintains its form

$$R = \gamma^{(is)} r + R_0 \quad , \quad R_0 = R|_{s=0} \quad , \quad k_0 = k|_{s=0} = R_0 + h \quad , \quad (3.124)$$

$$\dot{r} = (1 - \beta^{(is)} r) \dot{s} \quad , \quad r|_{s=0} = 0 \quad \Leftrightarrow \quad (3.125)$$

$$\dot{R} = [\gamma^{(is)} - \beta^{(is)}(R - R_0)] \dot{s} \quad \Leftrightarrow \quad \dot{k} = [\gamma^{(is)} - \beta^{(is)}(k - k_0)] \dot{s} \quad , \quad (3.126)$$

but now \dot{s} is given as in Eq. (3.121).

Proceeding to establish the resulting kinematic hardening rule, we rewrite Eq. (3.72) by adding the term $\hat{\mathbf{L}}_p \hat{\mathbf{Y}} - \hat{\mathbf{L}}_p \hat{\mathbf{Y}}$ on the left hand side, keeping in mind that $\hat{\hat{\mathbf{c}}}_p = \hat{\mathbf{L}}_p - \hat{\hat{\mathbf{Q}}}_p = \hat{\mathbf{D}}_p$:

$$\dot{\hat{\mathbf{Y}}} - \hat{\mathbf{L}}_p \hat{\mathbf{Y}} + \hat{\mathbf{Y}} \hat{\mathbf{L}}_p + \hat{\mathbf{D}}_p \hat{\mathbf{Y}} = \hat{\mathbf{D}}_p - \sqrt{\frac{3}{2}} \dot{s} (2b_1 \hat{\mathbf{Z}}_S + 2b_2 \hat{\mathbf{Z}}_A) \quad , \quad (3.127)$$

or

$$\dot{\hat{\mathbf{Y}}} - \hat{\mathbf{L}}_p \hat{\mathbf{Y}} + \hat{\mathbf{Y}} \hat{\mathbf{L}}_p = \hat{\mathbf{D}}_p (\mathbf{1} - \hat{\mathbf{Y}}) - \dot{s} \left\{ (b_1^* + b_2^*) \hat{\mathbf{Z}} + (b_1^* - b_2^*) \hat{\mathbf{Z}}^T \right\} \quad . \quad (3.128)$$

Again, \dot{s} is defined as in (3.121) and $b_1^* = \sqrt{6}b_1$, $b_2^* = \sqrt{6}b_2$. From Eq. (3.128) it can be concluded that $\hat{\mathbf{Y}}$ will be generally nonsymmetric. This will be true even if $b_1^* = b_2^* = 0$. Consequently, it is natural to assume the conjugate stress tensor $\hat{\mathbf{Z}}$ and the related backstress tensor $\hat{\hat{\boldsymbol{\xi}}}$ as in Eqs. (3.70) and (3.69), respectively. Since $\hat{\mathbf{Y}}_c$ should not be present in the free energy function, we set $c_4 = c_5 = c_6 = 0$, and without loss of generality, we set $b_{c1} = b_{c2} = 0$, so that $\hat{\hat{\mathbf{Y}}}_c = \mathbf{0}$, by virtue of (3.120).

3.7 Concluding remarks

In the classical limit of the elastic-plastic model the elastic rotation \mathbf{R}_e becomes equal to the micropolar elastic rotation $\bar{\mathbf{R}}_e$, whereas the plastic material spin $\hat{\mathbf{W}}_p$ becomes equal to the plastic microgyration tensor $\hat{\hat{\mathbf{Q}}}_p$ and therefore $\mathbf{R}_p \neq \bar{\mathbf{R}}_p$ in general. This is different from other approaches in the literature where $\mathbf{R} = \bar{\mathbf{R}}$ is often assumed to apply. Also the resulting classical model is characterized by an elasticity law with respect to the Biot stress tensor relative to the plastic intermediate configuration, and a von Mises yield function expressed in terms of Mandel stress tensors. The flow rule represents an associated normality condition, and the isotropic hardening rule remains unchanged. It turns out that the most interesting result concerns kinematic hardening. In fact, if the yield function is an isotropic tensor function of an effective stress tensor, as, e.g., $\hat{\mathbf{P}} - \hat{\hat{\boldsymbol{\xi}}}$, then almost all classical plasticity models deal with symmetric back stress tensors. Furthermore, the free energy function is assumed to depend on an internal strain tensor $\hat{\mathbf{Y}}$ responsible for kinematic hardening, which is also symmetric. Consequently only corotational or upper and lower Oldroyd time derivatives are invoked in the evolution equations governing the response of kinematic hardening (see, e.g., [157]). Opposite to such classical models, in the derived limiting classical model the internal strain $\hat{\mathbf{Y}}$ is nonsymmetric and the evolution equation for $\hat{\mathbf{Y}}$ is formulated by means of a mixed Oldroyd time derivative. Note that van der Giessen [63, 64] proposed an interesting plasticity theory, in which the yield function is expressed in terms of Mandel

stress tensors as well. Mixed Oldroyd time derivative is invoked also in this theory, but the evolution equation is formulated direct for the back stress tensor $\hat{\xi}$. Opposite to this theory, the back stress tensor $\hat{\xi}$ in the present paper is given as a function of \hat{Y} and $\hat{Z}(\hat{Y})$ and a mixed Oldroyd time derivative is used to specify the evolution of \hat{Y} . Of course, it is of general interest to discuss characteristic properties of the resulting limiting model with reference to other standard classical plasticity models. This will then be the aim of Part II.

Appendix

3.8 Derivation of balance laws for momentum and moment of momentum according to Mindlin's approach

Having available the definition of the microcontinuum, the kinematical relations and the equations describing conservation of mass (see Sect. 3.3.2), Mindlin's approach for deriving the balance laws of momentum and of moment of momentum can be extended from small to finite deformations. The conception of this approach may be described as follows. When dealing with materials whose response is governed by higher order stresses, to establish the local equations of motion on a purely geometrical way, it may become quickly hard to follow. Alternatively, one may use Hamilton's principle to derive these equations. It is emphasized, that this principle concerns only conservative mechanical systems and is equivalent to the local equations of motion, provided all functions involved are sufficiently smooth. However, although the local equations of motion will be derived in the framework of conservative systems, they still apply to every mechanical system governed by similar higher order stresses. Consequently, they can be utilized for the elastic-plastic materials addressed in the present paper. Another important reason for employing this approach is to derive rigorously the local equations of motion for the macrocontinuum by using appropriate averages of the microcontinuum, as we shall see.

3.8.1 Hamilton's principle for pure elastic materials

Hamilton's principle for independent variations $\delta \mathbf{u}$ and $\delta \bar{\mathbf{R}}$ of displacement $\mathbf{u} := \mathbf{x} - \mathbf{X}$ and micropolar rotation $\bar{\mathbf{R}}$, and fixed times t_0, t_1 , reads

$$\delta \left(\int_{t_0}^{t_1} K dt + \int_{t_0}^{t_1} W_e dt \right) = \delta \int_{t_0}^{t_1} W dt \quad , \quad (3.129)$$

or

$$\int_{t_0}^{t_1} \delta K dt + \int_{t_0}^{t_1} \delta W_e dt = \int_{t_0}^{t_1} \delta W dt \quad . \quad (3.130)$$

Here, K and W_e are the total kinetic energy and the work done by external forces for the macrocontinuum, respectively, while the work of the internal forces is designated by W . Variations $\delta \mathbf{u}$ and $\delta \bar{\mathbf{R}}$, as well as quantities K, W_e, W are defined in the following sections.

3.8.2 Variation of \mathbf{u} and $\bar{\mathbf{R}}$

Let $\partial\mathcal{R}_t^{u_i}$ be the part of the boundary where the displacement components u_i are prescribed, $u_i = u_i^0$ on $\partial\mathcal{R}_t^{u_i}$. Variations $\delta\mathbf{u} = \delta\mathbf{u}(\mathbf{x}, t)$ are defined to be, as sufficiently as needed, smooth functions vanishing on $\partial\mathcal{R}_t^{u_i}$, i.e., $\delta u_i = 0$ on $\partial\mathcal{R}_t^{u_i}$. Moreover, $\delta\mathbf{u}$ have to vanish everywhere at times t_0 and t_1 , $\delta\mathbf{u} \equiv \mathbf{0}$ on \mathcal{R}_{t_0} or \mathcal{R}_{t_1} .

In order to introduce variations $\delta\bar{\mathbf{R}}$, of the micropolar rotation $\bar{\mathbf{R}}$, we assume $\boldsymbol{\varphi} = \varphi_i \mathbf{e}_i$ to be the axial vector of the skew-symmetric tensor associated with the micropolar rotation $\bar{\mathbf{R}}$ (cf. Eq. (3.19)):

$$\bar{\mathbf{R}} = \exp(\boldsymbol{\Phi}) = \exp(\text{Spn}(\boldsymbol{\varphi})) \quad . \quad (3.131)$$

Let $\partial\mathcal{R}_t^{\varphi_i}$ be the part of $\partial\mathcal{R}_t$ where rotation boundary conditions are prescribed, $\varphi_i = \varphi_i^0$ on $\partial\mathcal{R}_t^{\varphi_i}$. We designate by $\bar{\mathbf{R}}_\varphi$ the value of $\bar{\mathbf{R}}$ for fixed $\boldsymbol{\varphi}$. If we superpose to $\bar{\mathbf{R}}_\varphi$ a further rotation $\mathbf{Q} = \mathbf{Q}(\xi\mathbf{M}) = \exp(\xi\mathbf{M})$, then $\bar{\mathbf{R}} = \mathbf{Q}\bar{\mathbf{R}}_\varphi$. Here, ξ is scalar-valued and $\mathbf{M} = \mathbf{M}(\mathbf{x}, t)$ is skew-symmetric second-order tensor. The variation of $\bar{\mathbf{R}}$ is defined by

$$\delta\bar{\mathbf{R}} = \left. \frac{\partial}{\partial\xi} \mathbf{Q}(\xi\mathbf{M})\bar{\mathbf{R}}_\varphi \right|_{\xi=0} \xi \quad . \quad (3.132)$$

By using the Euler-Rodrigues formula (3.20),

$$\delta\bar{\mathbf{R}} = (\xi\mathbf{M})\bar{\mathbf{R}}_\varphi = \delta\mathbf{M}\bar{\mathbf{R}}_\varphi \quad , \quad (3.133)$$

with

$$\delta\mathbf{M} = \delta\mathbf{M}(\mathbf{x}, t) := \xi\mathbf{M} = \text{Spn}(\delta\mathbf{m}) \Leftrightarrow \delta\mathbf{m} = \text{axl}(\delta\mathbf{M}) \quad . \quad (3.134)$$

Additionally, the variations $\delta\mathbf{m} = \delta\mathbf{m}(\mathbf{x}, t)$ are required to be, as sufficiently as needed, smooth functions vanishing on $\partial\mathcal{R}_t^{\varphi_i}$ and satisfying $\delta\mathbf{m} \equiv \mathbf{0}$ on \mathcal{R}_{t_0} or \mathcal{R}_{t_1} .

3.8.3 Kinetic energy of the macroscopic continuum

The total kinetic energy of the macrocontinuum is given by (cf. [122])

$$K := \int_{\mathcal{R}_{\mathcal{R}}} T dV \equiv \int_{\mathcal{R}_t} \tau dv \quad , \quad (3.135)$$

where T is the density of kinetic energy of the macroscopic continuum at \mathbf{X} per unit volume of the reference configuration of the macroscopic continuum, and τ is the density of kinetic energy of the macroscopic continuum at \mathbf{x} per unit volume of the actual configuration of the macroscopic continuum.

We define

$$T = T(\mathbf{X}, t) := \frac{1}{2} \langle \varrho'_{\mathcal{R}}(\mathbf{X}, \mathbf{X}') \rangle_{\mathcal{R}_{\mathcal{R}}} \langle (\mathbf{x} + \mathbf{x}') \cdot (\mathbf{x} + \mathbf{x}') \rangle_{\mathcal{R}_{\mathcal{R}}} = \frac{\varrho_{\mathcal{R}}}{2} \langle (\mathbf{x} + \mathbf{x}') \cdot (\mathbf{x} + \mathbf{x}') \rangle_{\mathcal{R}_{\mathcal{R}}} \quad , \quad (3.136)$$

$$\tau = \tau(\mathbf{x}, t) := \frac{1}{2} \langle \varrho'_{\mathcal{R}}(\mathbf{x}, \mathbf{x}', t) \rangle_{\mathcal{R}_t} \langle (\mathbf{x} + \mathbf{x}') \cdot (\mathbf{x} + \mathbf{x}') \rangle_{\mathcal{R}_t} = \frac{\varrho}{2} \langle (\mathbf{x} + \mathbf{x}') \cdot (\mathbf{x} + \mathbf{x}') \rangle_{\mathcal{R}_t} \quad , \quad (3.137)$$

where $\langle (\mathbf{x} + \mathbf{x}') \cdot (\mathbf{x} + \mathbf{x}') \rangle_{\mathcal{R}_{\mathcal{R}}}$ and $\langle (\mathbf{x} + \mathbf{x}') \cdot (\mathbf{x} + \mathbf{x}') \rangle_{\mathcal{R}_t}$ are respectively averages of squares of velocities to be defined appropriately, and use has been made of (3.37) and (3.39). In order that definitions (3.136) and (3.137) are compatible with (3.135), we have to prove that

$$TdV = \tau dv \quad . \quad (3.138)$$

In addition, we shall show that T and τ obey the representations

$$T = \frac{\rho_{\mathcal{R}}}{2} (\dot{\mathbf{x}} \cdot \dot{\mathbf{x}}) + \frac{\rho_{\mathcal{R}}}{2} \dot{\mathbf{R}}^T \dot{\mathbf{R}} \cdot \Theta \quad , \quad (3.139)$$

$$\tau = \frac{\rho}{2} (\dot{\mathbf{x}} \cdot \dot{\mathbf{x}}) + \frac{\rho}{2} \Omega^T \Omega \cdot \theta \quad , \quad (3.140)$$

where Θ and θ are Lagrangean and Eulerian second-order tensors, respectively, to be given below. They fulfill the transformation formula

$$\theta = \bar{\mathbf{R}} \Theta \bar{\mathbf{R}}^T \quad . \quad (3.141)$$

To prove Eqs. (3.138)–(3.140), we consider two possibilities for the material point $\mathbf{X}' = \mathbf{0}$ of the microcontinuum. In the first possibility, we assume this point to be the volume centroid of the microcontinuum, i.e.,

$$\int_{\mathcal{R}'_{\mathcal{R}}} \mathbf{X}' dV' = \mathbf{0} \quad . \quad (3.142)$$

As the deformation of the microcontinuum is homogeneous, we have $\mathbf{X}' = \bar{\mathbf{R}}^T \mathbf{x}'$, so that Eq. (3.142) is equivalent to

$$\bar{\mathbf{R}}^T \int_{\mathcal{R}'_t} \mathbf{x}' dv' = \mathbf{0} \quad , \quad (3.143)$$

where (3.29) has been taken into account. Since $\bar{\mathbf{R}}$ is a regular mapping, the linear equation (3.143) possesses only the trivial solution

$$\int_{\mathcal{R}'_t} \mathbf{x}' dv' = \mathbf{0} \quad . \quad (3.144)$$

In other words, the material point of the microcontinuum which is volume centroid in the reference configuration remains volume centroid in the actual configuration as well. From Eq. (3.144),

$$\int_{\mathcal{R}'_t} \dot{\mathbf{x}}' dv' = \mathbf{0} \quad . \quad (3.145)$$

According to the first possibility, $\langle (\mathbf{x} + \mathbf{x}') \cdot (\mathbf{x} + \mathbf{x}') \rangle_{\mathcal{R}_{\mathcal{R}}}$ and $\langle (\mathbf{x} + \mathbf{x}') \cdot (\mathbf{x} + \mathbf{x}') \rangle_{\mathcal{R}_t}$ are given by the following volume averages:

$$\langle (\mathbf{x} + \mathbf{x}') \cdot (\mathbf{x} + \mathbf{x}') \rangle_{\mathcal{R}_{\mathcal{R}}} := \frac{1}{V'} \int_{\mathcal{R}'_{\mathcal{R}}} (\mathbf{x} + \mathbf{x}') \cdot (\mathbf{x} + \mathbf{x}') dV' \quad , \quad (3.146)$$

$$\langle (\mathbf{x} + \mathbf{x}') \cdot (\mathbf{x} + \mathbf{x}') \rangle_{\mathcal{R}_t} := \frac{1}{v'} \int_{\mathcal{R}'_t} (\mathbf{x} + \mathbf{x}') \cdot (\mathbf{x} + \mathbf{x}') dv' \quad . \quad (3.147)$$

It follows from Eqs. (3.136) and (3.137) that

$$T = \frac{\rho_{\mathcal{R}}}{2} \left\{ \frac{1}{V'} \int_{\mathcal{R}'_{\mathcal{R}}} (\mathbf{x} + \mathbf{x}') \cdot (\mathbf{x} + \mathbf{x}') dV' \right\} = \frac{\rho_{\mathcal{R}}}{2} (\dot{\mathbf{x}} \cdot \dot{\mathbf{x}}) + \frac{\rho_{\mathcal{R}}}{2} \left\{ \frac{1}{V'} \int_{\mathcal{R}'_{\mathcal{R}}} \dot{\mathbf{x}}' \cdot \dot{\mathbf{x}}' dV' \right\} \quad (3.148)$$

and

$$\tau = \frac{\rho}{2} \left\{ \frac{1}{v'} \int_{\mathcal{R}'_t} (\mathbf{x} + \mathbf{x}') \cdot (\mathbf{x} + \mathbf{x}') \cdot dv' \right\} = \frac{\rho}{2} (\dot{\mathbf{x}} \cdot \dot{\mathbf{x}}) + \frac{\rho}{2} \left\{ \frac{1}{v'} \int_{\mathcal{R}'_t} \dot{\mathbf{x}}' \cdot \dot{\mathbf{x}}' dv' \right\} . \quad (3.149)$$

It is worth emphasizing that Eq. (3.148) corresponds to the kinetic energy density proposed by Mindlin [122], when "the material is composed wholly of unit cells". Also, it is not difficult to verify (by using relations of Sects. 3.3.1 and 3.3.2) that Eqs. (3.148) and (3.149) satisfy the equivalence relation (3.138).

In order to recast T and τ , we define the second-order tensors Θ and θ by the volume averages

$$\Theta = \Theta(\mathbf{X}) := \frac{1}{V'} \int_{\mathcal{R}'_{\mathcal{R}}} \mathbf{X}' \otimes \mathbf{X}' dV' = \Theta^T , \quad (3.150)$$

$$\theta = \theta(\mathbf{x}, t) := \frac{1}{v'} \int_{\mathcal{R}'_t} \mathbf{x}' \otimes \mathbf{x}' dv' = \theta^T . \quad (3.151)$$

Recalling that $\mathbf{x}' = \bar{\mathbf{R}}\mathbf{X}'$, $\dot{\mathbf{x}}' = \Omega\mathbf{x}'$, one can easily deduce on the one hand that Eq. (3.141) holds, and on the other hand that

$$\frac{1}{V'} \int_{\mathcal{R}'_{\mathcal{R}}} \dot{\mathbf{x}}' \cdot \dot{\mathbf{x}}' dV' \equiv \frac{1}{v'} \int_{\mathcal{R}'_t} \dot{\mathbf{x}}' \cdot \dot{\mathbf{x}}' dv' = \dot{\mathbf{R}}^T \dot{\mathbf{R}} \cdot \Theta = \Omega^T \Omega \cdot \theta . \quad (3.152)$$

After inserting into Eqs. (3.148) and (3.149), we obtain Eqs. (3.139) and (3.140).

According to the second possibility, we assume the point of the microcontinuum at \mathbf{X} with $\mathbf{X}' = \mathbf{0}$ to be the center of mass, i.e.,

$$\int_{\mathcal{R}'_{\mathcal{R}}} \mathbf{X}' \varrho'_{\mathcal{R}} dV' = \mathbf{0} , \quad (3.153)$$

which is equivalent to

$$\int_{\mathcal{R}'_t} \mathbf{x}' \varrho' dv' = \mathbf{0} . \quad (3.154)$$

That means, the material point of the microcontinuum which is center of mass in the reference configuration remains center of mass in every configuration during the motion of the material body. Moreover,

$$\frac{d}{dt} \int_{\mathcal{R}'_t} \mathbf{x}' \varrho' dv' = \int_{\mathcal{R}'_t} \dot{\mathbf{x}}' \varrho' dv' = \mathbf{0} . \quad (3.155)$$

These results go back to Eringen (see e.g. [46, p. 31]).

Now, we define $\langle (\mathbf{x} + \mathbf{x}') \cdot (\mathbf{x} + \mathbf{x}') \cdot \rangle_{\mathcal{R}_{\mathcal{R}}}$ and $\langle (\mathbf{x} + \mathbf{x}') \cdot (\mathbf{x} + \mathbf{x}') \cdot \rangle_{\mathcal{R}_t}$ by the mass averages

$$\langle (\mathbf{x} + \mathbf{x}') \cdot (\mathbf{x} + \mathbf{x}') \cdot \rangle_{\mathcal{R}_{\mathcal{R}}} := \frac{1}{\int_{\mathcal{R}'_{\mathcal{R}}} \varrho'_{\mathcal{R}}(\mathbf{X}, \mathbf{X}') dV'} \int_{\mathcal{R}'_{\mathcal{R}}} (\mathbf{x} + \mathbf{x}') \cdot (\mathbf{x} + \mathbf{x}') \cdot \varrho'_{\mathcal{R}}(\mathbf{X}, \mathbf{X}') dV' \quad (3.156)$$

and

$$\langle (\mathbf{x} + \mathbf{x}') \cdot (\mathbf{x} + \mathbf{x}') \cdot \rangle_{\mathcal{R}_t} := \frac{1}{\int_{\mathcal{R}'_t} \chi(\mathbf{x}, t) \varrho'(\mathbf{x}, \mathbf{x}', t) dv'} \int_{\mathcal{R}'_t} \chi(\mathbf{x}, t) [(\mathbf{x} + \mathbf{x}') \cdot (\mathbf{x} + \mathbf{x}') \cdot] \varrho'(\mathbf{x}, \mathbf{x}', t) dv' , \quad (3.157)$$

respectively. After inserting into Eqs. (3.136) and (3.137), and making use of Eqs. (3.153)–(3.155) and the relations (cf. Eqs. (3.37) and (3.39))

$$\varrho_{\mathcal{R}} V' = \int_{\mathcal{R}'_{\mathcal{R}}} \varrho'_{\mathcal{R}} dV' \quad , \quad \varrho v' = \int_{\mathcal{R}'_t} \chi \varrho' dv' \quad , \quad (3.158)$$

we conclude that

$$T = \frac{\varrho_{\mathcal{R}}}{2} \left\{ \frac{1}{\varrho_{\mathcal{R}} V'} \int_{\mathcal{R}'_{\mathcal{R}}} (\mathbf{x} + \mathbf{x}') \cdot (\mathbf{x} + \mathbf{x}') \cdot \varrho'_{\mathcal{R}} dV' \right\} = \frac{\varrho_{\mathcal{R}}}{2} (\dot{\mathbf{x}} \cdot \dot{\mathbf{x}}) + \frac{\varrho_{\mathcal{R}}}{2} \left\{ \frac{1}{\varrho_{\mathcal{R}} V'} \int_{\mathcal{R}'_{\mathcal{R}}} (\dot{\mathbf{x}}' \cdot \dot{\mathbf{x}}') \varrho'_{\mathcal{R}} dV' \right\} \quad (3.159)$$

and

$$\tau = \frac{\varrho}{2} \left\{ \frac{1}{\varrho v'} \int_{\mathcal{R}'_t} \chi (\mathbf{x} + \mathbf{x}') \cdot (\mathbf{x} + \mathbf{x}') \cdot \varrho' dv' \right\} = \frac{\varrho}{2} (\dot{\mathbf{x}} \cdot \dot{\mathbf{x}}) + \frac{\varrho}{2} \left\{ \frac{1}{\varrho v'} \int_{\mathcal{R}'_t} \chi (\dot{\mathbf{x}}' \cdot \dot{\mathbf{x}}') \varrho' dv' \right\} \quad . \quad (3.160)$$

It is easy to confirm (by using relations of Sects. 3.3.1 and 3.3.2), on the one hand, that Eqs. (3.159) and (3.160) satisfy Eq. (3.138), and on the other hand that T and τ may be represented by Eqs. (3.139)–(3.141), provided Θ and θ are now defined by the mass averages

$$\Theta = \Theta(\mathbf{X}) := \frac{1}{\varrho_{\mathcal{R}} V'} \int_{\mathcal{R}'_{\mathcal{R}}} \mathbf{X}' \otimes \mathbf{X}' \varrho'_{\mathcal{R}} dV' \quad , \quad (3.161)$$

$$\theta = \theta(\mathbf{x}, t) := \frac{1}{\varrho v'} \int_{\mathcal{R}'_t} \chi (\mathbf{x}' \otimes \mathbf{x}') \varrho' dv' \quad . \quad (3.162)$$

Note that the tensors Θ and θ in these equations correspond to the microinertia tensors introduced by Eringen (see e.g. [46, p. 32]). From Eqs. (3.135) and (3.139)

$$\int_{t_0}^{t_1} \delta K dt = - \int_{t_0}^{t_1} \left\{ \int_{\mathcal{R}_{\mathcal{R}}} (\varrho_{\mathcal{R}} \ddot{\mathbf{x}} \cdot \delta \mathbf{u} + \varrho_{\mathcal{R}} \Theta \cdot \ddot{\mathbf{R}}^T \delta \bar{\mathbf{R}}) dV \right\} dt \quad , \quad (3.163)$$

where use is made of partial integration and of the fact that $\delta \mathbf{u}$ and $\delta \bar{\mathbf{R}}$ vanish at times t_0 and t_1 .

Clearly, instead of $\delta \bar{\mathbf{R}}$ one may utilize the axial vector $\delta \mathbf{m}$ in order to rewrite Eq. (3.163). To this end, we recast the term $\Theta \cdot \ddot{\mathbf{R}}^T \delta \bar{\mathbf{R}}$ in (3.163) as follows:

$$\begin{aligned} \Theta \cdot \ddot{\mathbf{R}}^T \delta \bar{\mathbf{R}} &= (\Omega \bar{\mathbf{R}}) \cdot \Theta \bar{\mathbf{R}}^T \cdot \delta \mathbf{M} \\ &= \{ (\Omega \bar{\mathbf{R}} \Theta \bar{\mathbf{R}}^T) \cdot - \Omega \bar{\mathbf{R}} (\Theta \bar{\mathbf{R}}^T) \} \cdot \delta \mathbf{M} \\ &= \{ (\Omega \theta) \cdot - \Omega \theta \Omega^T \} \cdot \delta \mathbf{M} \\ &= (\Omega \theta) \cdot \delta \mathbf{M} \\ &= (\Omega \theta)_{ij} e_{jik} \delta m_k \quad . \end{aligned} \quad (3.164)$$

Following Eringen [46, p. 33], we define a "micro-rotation inertia vector" σ by

$$\sigma := (\Omega \theta)_{ij} e_{jik} \mathbf{e}_k \quad (3.165)$$

so that

$$\Theta \cdot \ddot{\mathbf{R}}^T \delta \bar{\mathbf{R}} = \dot{\sigma} \cdot \delta \mathbf{m} \quad . \quad (3.166)$$

After some algebraic manipulations,

$$\boldsymbol{\sigma} = \mathbf{j}\boldsymbol{\omega} \quad , \quad \mathbf{j} := (\text{tr}\boldsymbol{\theta})\mathbf{1} - \boldsymbol{\theta} \quad , \quad (3.167)$$

which has been introduced by Eringen (see e.g. [46, p. 33]).

This way, Eq. (3.163) takes the form

$$\int_{t_0}^{t_1} \delta K dt = - \int_{t_0}^{t_1} \left\{ \int_{\mathcal{R}_t} (\varrho \ddot{\mathbf{x}} \cdot \delta \mathbf{u} + \varrho \dot{\boldsymbol{\sigma}} \cdot \delta \mathbf{m}) dv \right\} dt \quad . \quad (3.168)$$

3.8.4 Work of the internal forces

The work of the internal forces will be stored in the material as potential energy W ,

$$W := \int_{\mathcal{R}_{\mathcal{R}}} \varrho_{\mathcal{R}} \Psi dV \equiv \int_{\mathcal{R}_t} \varrho \Psi dv \quad , \quad (3.169)$$

with Ψ being given by Eq. (3.35). Now we define the stress tensors

$$\tilde{\mathbf{T}} := \varrho_{\mathcal{R}} \frac{\partial \tilde{\Psi}}{\partial \tilde{\boldsymbol{\epsilon}}} \quad , \quad \mathbf{S} := \bar{\mathbf{R}} \tilde{\mathbf{T}} \mathbf{F}^T \quad , \quad \mathbf{T} := \frac{1}{\det \mathbf{F}} \mathbf{S} \quad , \quad (3.170)$$

and the couple stress tensors

$$\tilde{\mathbf{T}}_c := \varrho_{\mathcal{R}} \frac{\partial \tilde{\Psi}}{\partial \tilde{\mathbf{K}}} \quad , \quad \mathbf{S}_c := \bar{\mathbf{R}} \tilde{\mathbf{T}}_c \bar{\mathbf{R}}^T \quad , \quad \mathbf{T}_c := \frac{1}{\det \mathbf{F}} \mathbf{S}_c \bar{\mathbf{V}}^T \quad . \quad (3.171)$$

Then,

$$\delta W = \int_{\mathcal{R}_{\mathcal{R}}} (\tilde{\mathbf{T}} \cdot \delta \tilde{\boldsymbol{\epsilon}} + \tilde{\mathbf{T}}_c \cdot \delta \tilde{\mathbf{K}}) dV \quad . \quad (3.172)$$

After some lengthy calculations, where use is made of integration by parts and the divergence theorem,

$$\begin{aligned} \int_{\mathcal{R}_{\mathcal{R}}} \tilde{\mathbf{T}} \cdot \delta \tilde{\boldsymbol{\epsilon}} dV &= \int_{\mathcal{R}_t} \mathbf{T} \cdot (\delta \mathbf{M}^T + (\delta \mathbf{F}) \mathbf{F}^{-1}) dv \\ &= \int_{\partial \mathcal{R}_t} (\mathbf{T} \mathbf{n}) \cdot \delta \mathbf{u} da - \int_{\mathcal{R}_t} \{ (\text{div} \mathbf{T}) \cdot \delta \mathbf{u} + \mathbf{t}_T \cdot \delta \mathbf{m} \} dv \quad , \end{aligned} \quad (3.173)$$

$$\begin{aligned} \int_{\mathcal{R}_{\mathcal{R}}} \tilde{\mathbf{T}}_c \cdot \delta \tilde{\mathbf{K}} dV &= \int_{\mathcal{R}_t} \mathbf{T}_c \cdot \text{grad} \delta \mathbf{m} dv \\ &= \int_{\partial \mathcal{R}_t} (\mathbf{T}_c \mathbf{n}) \cdot \delta \mathbf{m} da - \int_{\mathcal{R}_t} (\text{div} \mathbf{T}_c) \cdot \delta \mathbf{m} dv \quad , \end{aligned} \quad (3.174)$$

where

$$\mathbf{t}_T := \text{axl}(\mathbf{T} - \mathbf{T}^T) \quad . \quad (3.175)$$

Substituting (3.173) and (3.174) into (3.172),

$$\delta W = \int_{\partial \mathcal{R}_t} \{ (\mathbf{T} \mathbf{n}) \cdot \delta \mathbf{u} + (\mathbf{T}_c \mathbf{n}) \cdot \delta \mathbf{m} \} da - \int_{\mathcal{R}_t} \{ (\text{div} \mathbf{T}) \cdot \delta \mathbf{u} + (\mathbf{t}_T + \text{div} \mathbf{T}_c) \cdot \delta \mathbf{m} \} dv \quad . \quad (3.176)$$

3.8.5 Work of the external forces

As suggested by Mindlin [122], Eq. (3.176) motivates to adopt the following form for δW_e :

$$\delta W_e = \int_{\partial \mathcal{R}_t} (\mathbf{t} \cdot \delta \mathbf{u} + \mathbf{t}_c \cdot \delta \mathbf{m}) da + \int_{\mathcal{R}_t} (\mathbf{b} \cdot \delta \mathbf{u} + \mathbf{b}_c \cdot \delta \mathbf{m}) dv \quad , \quad (3.177)$$

where \mathbf{t} , \mathbf{t}_c are respectively the surface force (traction) and the couple surface force (couple traction) per unit area of the actual configuration of the macroscopic continuum, and \mathbf{b} , \mathbf{b}_c are respectively the body force and the couple body force per unit volume of the actual configuration of the macroscopic continuum.

3.8.6 Local equations of motion

We now insert Eqs. (3.177), (3.176) and (3.168) into Eq. (3.130) and drop the integration with respect to time to get

$$\begin{aligned} & \int_{\partial \mathcal{R}_t} (\mathbf{t} - \mathbf{T}\mathbf{n}) \cdot \delta \mathbf{u} da + \int_{\partial \mathcal{R}_t} (\mathbf{t}_c - \mathbf{T}_c \mathbf{n}) \cdot \delta \mathbf{m} da \\ & + \int_{\mathcal{R}_t} \{\text{div} \mathbf{T} + \mathbf{b} - \rho \ddot{\mathbf{x}}\} \cdot \delta \mathbf{u} dv + \int_{\mathcal{R}_t} \{\mathbf{t}_T + \text{div} \mathbf{T}_c + \mathbf{b}_c - \rho \dot{\boldsymbol{\sigma}}\} \cdot \delta \mathbf{m} dv = 0 \quad . \end{aligned} \quad (3.178)$$

Necessary and sufficient conditions in order for Eq. (3.178) to be satisfied for arbitrary variations $\delta \mathbf{u}$ and $\delta \mathbf{m}$ are the local equations of motion

$$\text{div} \mathbf{T} + \mathbf{b} = \rho \ddot{\mathbf{x}} \quad \text{in } \mathcal{R}_t \quad , \quad (3.179)$$

$$\mathbf{t}_T + \text{div} \mathbf{T}_c + \mathbf{b}_c = \rho \dot{\boldsymbol{\sigma}} \quad \text{in } \mathcal{R}_t \quad , \quad (3.180)$$

together with the boundary conditions

$$T_{ij} n_j = t_i = t_i^0 \quad \text{on } \partial \mathcal{R}_t^{t_i} = \partial \mathcal{R}_t \setminus \partial \mathcal{R}_t^{u_i} \quad , \quad (3.181)$$

$$(\mathbf{T}_c)_{ij} n_j = (\mathbf{t}_c)_i = (\mathbf{t}_c)_i^0 \quad \text{on } \partial \mathcal{R}_t^{(\mathbf{t}_c)_i} = \partial \mathcal{R}_t \setminus \partial \mathcal{R}_t^{\varphi_i} \quad , \quad (3.182)$$

$$\delta u_i = 0 \quad \text{on } \partial \mathcal{R}_t^{u_i} \quad \text{and} \quad u_i = u_i^0 \quad \text{on } \partial \mathcal{R}_t^{u_i} \quad , \quad (3.183)$$

$$\delta m_i = 0 \quad \text{on } \partial \mathcal{R}_t^{\varphi_i} \quad \text{and} \quad \varphi_i = \varphi_i^0 \quad \text{on } \partial \mathcal{R}_t^{\varphi_i} \quad . \quad (3.184)$$

Concluding, once more it is emphasized that relations (3.179)–(3.184) have been derived here by confining to pure elasticity, but otherwise they are valid for all micropolar materials, irrespective of particular constitutive properties.

4 Micropolar plasticity theories and their classical limits. Part II: Comparison of responses predicted by the limiting and a standard classical model

P. Grammenoudis, Ch. Sator, Ch. Tsakmakis

Acta Mechanica, 189 (2007) 3-4, 177-191

**Micropolar plasticity theories and their classical limits.
Part II: Comparison of responses predicted by the limiting and
a standard classical model**

P. Grammenoudis, Ch. Sator, Ch. Tsakmakis

**Darmstadt University of Technology, Institute of Continuum Mechanics,
Hochschulstraße 1, 64289 Darmstadt, Germany**

Abstract

The paper is concerned with the limiting classical model which may be approached by a micropolar plasticity theory proposed previously. The aim is to investigate the limiting classical model in comparison with some standard classical plasticity models. The essential differences to such models consist in the constitutive equations governing kinematic hardening. As shown in the paper, this causes different responses mainly in the so-called second-order effects.

4.1 Introduction

Standard classical finite deformation plasticity models are characterized by the multiplicative decomposition of the deformation gradient tensor into elastic and plastic parts, an elasticity law for the stress tensor, a flow rule for the plastic deformation, and constitutive equations governing the hardening response. Plastic flow is postulated to occur whenever so-called loading criteria are satisfied, the latter being defined with the help of the concept of a yield function and the related yield surface. Isotropic and kinematic hardening may be modelled by stress like tensors which appear in the yield function, represented in the stress space. If the theory is thermodynamically consistent formulated, then the yield function depends commonly on the so-called Mandel stress tensor. Also the back stress tensor describing kinematic hardening is assumed to possess the mathematical structure of a Mandel stress tensor (see, e.g., [157] and [162]). For many practical problems it suffices to focus attention to yield and free energy functions, which are scalar valued isotropic tensor functions of their arguments. In this case, symmetric strain and stress tensors are usually employed to model kinematic hardening effects. This imposes to use upper and lower Oldroyd time derivatives in the evolution equations, whenever time derivatives of Oldroyd type come into question. In fact, use of mixed Oldroyd derivatives causes generally not symmetric fluxes.

In this paper we are concerned with the plasticity model obtained as a classical limit of the micropolar plasticity theory proposed by Grammenoudis and Tsakmakis [67, 69]. The limiting model has been derived in Part I of this series of papers and exhibits a kinematic hardening rule invoking mixed Oldroyd time derivatives and non-symmetric internal strain and stress tensorial variables. As mentioned in Part I, van der Giessen [63, 64] proposed also a kinematic hardening rule with a back stress tensor of

Mandel type related to an evolution equation where use is made of mixed Oldroyd time derivatives. However, as explained in Part I, there are some conceptual differences between the two kinematic hardening rules, not discussed further here. The present work aims to illustrate typical properties of the classical limiting model in comparison with standard classical plasticity models. It is shown that the main differences in predicted responses are in so-called second-order effects. It can be seen that isotropic hardening may not affect the obtained results. Therefore, in what follows isotropic hardening will be omitted.

4.2 The limiting classical model (LCM)

Using the same notation as in Part I, the limiting classical model may be summarized, relative to the plastic intermediate configuration, as follows:

$$\hat{\mathbf{\Gamma}} = \mathbf{F}_p^{T-1} \frac{1}{2} (\mathbf{F}^T \mathbf{F} - \mathbf{1}) \mathbf{F}_p^{-1} = \hat{\mathbf{\Gamma}}_e + \hat{\mathbf{\Gamma}}_p \quad , \quad \hat{\mathbf{\Gamma}}_e = \frac{1}{2} (\hat{\mathbf{U}}_e^2 - \mathbf{1}) \quad , \quad \hat{\mathbf{\Gamma}}_p = \frac{1}{2} (\mathbf{1} - \mathbf{V}_p^{-2}) \quad , \quad (4.1)$$

$$\hat{\mathbf{S}}_B = \mathbf{R}_e^T \mathbf{S} \mathbf{F}_e^{T-1} = \lambda \{ \text{tr}(\mathbf{U}_e - \mathbf{1}) \} \mathbf{1} + 2\mu (\mathbf{U}_e - \mathbf{1}) \quad , \quad (4.2)$$

$$\hat{\mathbf{P}} = (\mathbf{1} + 2\hat{\mathbf{\Gamma}}_e) \hat{\mathbf{S}} \quad , \quad \hat{\mathbf{S}} = \mathbf{F}_e^{-1} \mathbf{S} \mathbf{F}_e^{T-1} = \mathbf{U}_e^{-1} \hat{\mathbf{S}}_B \quad , \quad (4.3)$$

$$f = \hat{f}(\hat{\mathbf{P}}, \hat{\boldsymbol{\xi}}) = \sqrt{\frac{3}{2} (\hat{\mathbf{P}} - \hat{\boldsymbol{\xi}}_S)^D \cdot (\hat{\mathbf{P}} - \hat{\boldsymbol{\xi}}_S)^D} - k \quad , \quad k = \text{const} \quad , \quad (4.4)$$

$$\hat{\mathbf{D}}_p = \dot{\hat{\mathbf{\Gamma}}}_p + \hat{\mathbf{L}}_p^T \hat{\mathbf{\Gamma}}_p + \hat{\mathbf{\Gamma}}_p \hat{\mathbf{L}}_p = \dot{s} \frac{\partial \hat{f}}{\partial \hat{\mathbf{P}}} = \frac{3\dot{s}}{2k} (\hat{\mathbf{P}} - \hat{\boldsymbol{\xi}}_S)^D \quad , \quad \dot{s} = \sqrt{\frac{2}{3} \hat{\mathbf{D}}_p \cdot \hat{\mathbf{D}}_p} \quad , \quad (4.5)$$

$$\hat{\boldsymbol{\xi}} = (\mathbf{1} - \hat{\mathbf{Y}}^T) \hat{\mathbf{Z}} \quad , \quad (4.6)$$

$$\hat{\mathbf{Z}} = c_1 (\text{tr} \hat{\mathbf{Y}}) \mathbf{1} + (c_2 + c_3) \hat{\mathbf{Y}} + (c_2 - c_3) \hat{\mathbf{Y}}^T \quad , \quad (4.7)$$

$$\dot{\hat{\mathbf{Y}}} - \hat{\mathbf{L}}_p \hat{\mathbf{Y}} + \hat{\mathbf{Y}} \hat{\mathbf{L}}_p = \hat{\mathbf{D}}_p (\mathbf{1} - \hat{\mathbf{Y}}) - \dot{s} \left\{ (b_1^* + b_2^*) \hat{\mathbf{Z}} + (b_1^* - b_2^*) \hat{\mathbf{Z}}^T \right\} \quad . \quad (4.8)$$

In comparing this model with a standard classical model, small elastic strains are assumed to apply. Then, Eq. (4.2) may be approximated (cf. Part I) by the elasticity law

$$\hat{\mathbf{S}} = \lambda (\text{tr} \hat{\mathbf{\Gamma}}_e) \mathbf{1} + 2\mu \hat{\mathbf{\Gamma}}_e \quad . \quad (4.9)$$

4.3 A standard classical model (SCM)

As mentioned in the introduction, standard classical plasticity models for finite deformations, are characterized by a symmetric internal strain tensor $\hat{\mathbf{Y}}$ responsible for kinematic hardening effects. Again, $\hat{\mathbf{Y}}$ is a strain tensor relative to the plastic intermediate configuration. Assuming the specific free energy $\Psi_p^{(kin)}$ to be an isotropic tensor function of $\hat{\mathbf{Y}}$, $\Psi_p^{(kin)} = \hat{\Psi}_p^{(kin)}(\hat{\mathbf{Y}})$, the thermodynamically conjugate internal stress tensor $\hat{\mathbf{Z}} := \varrho_{\mathcal{R}} \frac{\partial \hat{\Psi}_p^{(kin)}}{\partial \hat{\mathbf{Y}}}$ is also symmetric, and additionally $\hat{\mathbf{Z}}$ is given also as isotropic tensor function of $\hat{\mathbf{Y}}$. Therefore, $\hat{\mathbf{Z}}$ and $\hat{\mathbf{Y}}$ possess the same principal axes. This implies that the back-stress tensor $\hat{\boldsymbol{\xi}}$ will always be symmetric, whenever $\hat{\boldsymbol{\xi}}$ will be represented as an isotropic tensor function of $\hat{\mathbf{Y}}$ and $\hat{\mathbf{Z}}(\hat{\mathbf{Y}})$. This is the case when $\hat{\boldsymbol{\xi}}$ is postulated to obey the mathematical structure of a Mandel stress tensor (see [157, 162]).

Some standard classical models exhibiting nonlinear kinematic hardening rules of Armstrong-Frederick type have been intensively discussed by Tsakmakis et al. (see e.g. [158, 36, 35, 162]). All constitutive equations are identical to those in Sect. 4.2, except of the kinematic hardening rule. As a typical example we refer to the kinematic hardening rule proposed in [162],

$$\hat{\boldsymbol{\xi}} = (\mathbf{1} + 2\hat{\mathbf{Y}})\hat{\mathbf{Z}} \quad , \quad (4.10)$$

$$\Psi_p^{(kin)} = \hat{\Psi}_p^{(kin)}(\hat{\mathbf{Y}}) = \frac{1}{2\varrho_{\mathcal{R}}} \left\{ c_1(\text{tr}(\hat{\mathbf{Y}}))^2 + c_2\hat{\mathbf{Y}} \cdot \hat{\mathbf{Y}} \right\} \quad , \quad (4.11)$$

$$\hat{\mathbf{Z}} = c_1(\text{tr}\hat{\mathbf{Y}})\mathbf{1} + c_2\hat{\mathbf{Y}} \quad , \quad (4.12)$$

$$\overset{\nabla}{\hat{\mathbf{Y}}} = \dot{\hat{\mathbf{Y}}} - \hat{\mathbf{L}}_p\hat{\mathbf{Y}} - \hat{\mathbf{Y}}\hat{\mathbf{L}}_p^T = \hat{\mathbf{D}}_p - \dot{s}b\hat{\mathbf{Z}} \quad . \quad (4.13)$$

4.4 Eulerian form of the two models

For implementing the two models into finite element codes like ABAQUS, all equations have to be transformed appropriately into the current configuration. It is emphasized that all physical aspects have already been incorporated in the formulation relative to the plastic intermediate configuration $\hat{\mathcal{R}}_t$. Therefore, the transformation formulas with respect to the current configuration \mathcal{R}_t will have formal character only and may be defined on the basis of reasons of convenience.

We shall transform the models into \mathcal{R}_t by using the Almansi strain tensor \mathbf{A} . Moreover we assume the elastic strains to be small. Then,

$$\mathbf{A} = \frac{1}{2}(\mathbf{1} - \mathbf{F}^{T-1}\mathbf{F}^{-1}) = \mathbf{F}_e^{T-1}\hat{\mathbf{\Gamma}}\mathbf{F}_e^{-1} \approx \mathbf{R}_e\hat{\mathbf{\Gamma}}\mathbf{R}_e^T \quad , \quad (4.14)$$

$$\mathbf{A} = \mathbf{A}_e + \mathbf{A}_p \quad , \quad (4.15)$$

$$\mathbf{A}_e = \frac{1}{2}(\mathbf{1} - \mathbf{B}_e^{-1}) = \mathbf{F}_e^{T-1}\hat{\mathbf{\Gamma}}_e\mathbf{F}_e^{-1} \approx \mathbf{R}_e\hat{\mathbf{\Gamma}}_e\mathbf{R}_e^T \quad , \quad (4.16)$$

$$\mathbf{A}_p = \mathbf{F}_e^{T-1}\hat{\mathbf{\Gamma}}_p\mathbf{F}_e^{-1} \approx \mathbf{R}_e\hat{\mathbf{\Gamma}}_p\mathbf{R}_e^T \quad , \quad (4.17)$$

which are Eulerian counterparts of Eqs. (4.1). The elasticity law (4.9) may be rewritten as

$$\mathbf{S} \approx \lambda(\text{tr}\mathbf{A}_e)\mathbf{1} + 2\mu\mathbf{A}_e \quad .$$

The definition

$$\boldsymbol{\xi} := \mathbf{F}_e\hat{\boldsymbol{\xi}}\mathbf{F}_e^T \approx \mathbf{R}_e\hat{\boldsymbol{\xi}}\mathbf{R}_e^T \quad (4.18)$$

and the relation

$$\mathbf{S} = \mathbf{F}_e^{T-1}\hat{\mathbf{P}}\mathbf{F}_e^T \approx \mathbf{R}_e\hat{\mathbf{P}}\mathbf{R}_e^T \quad (4.19)$$

enable to obtain for the yield function in (4.4)

$$f = \bar{f}(\mathbf{S}, \boldsymbol{\xi}_S) = \sqrt{\frac{3}{2}(\mathbf{S} - \boldsymbol{\xi}_S)^D \cdot (\mathbf{S} - \boldsymbol{\xi}_S)^D} - k \quad , \quad k = \text{const} \quad . \quad (4.20)$$

We remark that

$$\hat{\mathbf{A}}_p := \dot{\mathbf{A}}_p + \mathbf{L}^T\mathbf{A}_p + \mathbf{A}_p\mathbf{L} = \mathbf{F}_e^{T-1}\hat{\mathbf{D}}_p\mathbf{F}_e^{-1} \approx \mathbf{R}_e\hat{\mathbf{D}}_p\mathbf{R}_e^T \quad . \quad (4.21)$$

Thus, the flow rule (4.5) yields

$$\hat{\mathbf{A}}_p \approx \frac{3\dot{s}}{2k}(\mathbf{S} - \boldsymbol{\xi}_S)^D \quad , \quad \dot{s} \approx \sqrt{\frac{2}{3}\hat{\mathbf{A}}_p \cdot \hat{\mathbf{A}}_p} \quad . \quad (4.22)$$

In order to transform the kinematic hardening rules we distinguish between two cases.

Limiting classical model

We define

$$\mathbf{Z} := \mathbf{F}_e^{T-1} \hat{\mathbf{Z}} \mathbf{F}_e^T \approx \mathbf{R}_e \hat{\mathbf{Z}} \mathbf{R}_e^T \quad , \quad \mathbf{Y} := \mathbf{F}_e \hat{\mathbf{Y}} \mathbf{F}_e^{-1} \approx \mathbf{R}_e \hat{\mathbf{Y}} \mathbf{R}_e^T \quad , \quad (4.23)$$

so that

$$\dot{\mathbf{Y}} - \mathbf{L}\mathbf{Y} + \mathbf{Y}\mathbf{L} = \mathbf{F}_e(\dot{\hat{\mathbf{Y}}} - \hat{\mathbf{L}}_p \hat{\mathbf{Y}} + \hat{\mathbf{Y}} \hat{\mathbf{L}}_p) \mathbf{F}_e^{-1} \approx \mathbf{R}_e(\dot{\hat{\mathbf{Y}}} - \hat{\mathbf{L}}_p \hat{\mathbf{Y}} + \hat{\mathbf{Y}} \hat{\mathbf{L}}_p) \mathbf{R}_e^T \quad . \quad (4.24)$$

It follows from Eqs. (4.6)–(4.8) and (4.18) that

$$\boldsymbol{\xi} \approx (\mathbf{1} - \mathbf{Y}^T) \mathbf{Z} \quad , \quad (4.25)$$

$$\mathbf{Z} \approx c_1(\text{tr} \mathbf{Y}) \mathbf{1} + (c_2 + c_3) \mathbf{Y} + (c_2 - c_3) \mathbf{Y}^T \quad , \quad (4.26)$$

$$\dot{\mathbf{Y}} - \mathbf{L}\mathbf{Y} + \mathbf{Y}\mathbf{L} \approx \hat{\mathbf{A}}_p(\mathbf{1} - \mathbf{Y}) - \dot{s} \{ (b_1^* + b_2^*) \mathbf{Z} + (b_1^* - b_2^*) \mathbf{Z}^T \} \quad . \quad (4.27)$$

Standard classical model

The definitions

$$\mathbf{Z} := \mathbf{F}_e^{T-1} \hat{\mathbf{Z}} \mathbf{F}_e^{-1} \approx \mathbf{R}_e \hat{\mathbf{Z}} \mathbf{R}_e^T \quad , \quad \mathbf{Y} := \mathbf{F}_e \hat{\mathbf{Y}} \mathbf{F}_e^T \approx \mathbf{R}_e \hat{\mathbf{Y}} \mathbf{R}_e^T \quad , \quad (4.28)$$

imply

$$\dot{\mathbf{Y}} - \mathbf{L}\mathbf{Y} - \mathbf{Y}\mathbf{L}^T = \mathbf{F}_e \{ \dot{\hat{\mathbf{Y}}} - \hat{\mathbf{L}}_p \hat{\mathbf{Y}} - \hat{\mathbf{Y}} \hat{\mathbf{L}}_p^T \} \mathbf{F}_e^T \approx \mathbf{R}_e \{ \dot{\hat{\mathbf{Y}}} - \hat{\mathbf{L}}_p \hat{\mathbf{Y}} - \hat{\mathbf{Y}} \hat{\mathbf{L}}_p^T \} \mathbf{R}_e^T \quad (4.29)$$

and hence

$$\boldsymbol{\xi} \approx (\mathbf{1} + 2\mathbf{Y}) \mathbf{Z} \quad , \quad (4.30)$$

$$\mathbf{Z} = c_1(\text{tr} \mathbf{Y}) \mathbf{1} + c_2 \mathbf{Y} \quad , \quad (4.31)$$

$$\dot{\mathbf{Y}} - \mathbf{L}\mathbf{Y} - \mathbf{Y}\mathbf{L}^T \approx \hat{\mathbf{A}}_p - \dot{s} b \mathbf{Z} \quad . \quad (4.32)$$

4.5 Comparative study of the two models

The two models established above have been implemented into the UMAT-subroutine of the finite element code ABAQUS. For the time integration of the constitutive equations an operator split algorithm according to [145] has been employed (more details may be found in [161]). The common material parameters for both models are chosen to be

$$\mu = 76923 \text{ MPa} \quad ,$$

$$\begin{aligned}\lambda &= 115384 \text{ MPa} \quad , \\ k &= 200 \text{ MPa} \quad ,\end{aligned}$$

while the material parameters appearing in the kinematic hardening rules are chosen as follows.

Limiting classical model

$$\begin{aligned}b_1^* &= b_2^* = 0,00125 \text{ [MPa]}^{-1} \quad , \\ c_1 &= 0 \quad , \\ c_2 &= c_3 = 10000 \text{ MPa} \quad .\end{aligned}$$

Standard classical model

$$\begin{aligned}c_1 &= 0 \quad , \\ c_2 &= 20000 \text{ MPa} \quad , \\ b &= 0,0025 \text{ [MPa]}^{-1} \quad .\end{aligned}$$

4.5.1 Uniaxial tension-compression loading

Strain controlled uniaxial homogeneous tension-compression loadings of a bar in the z -direction are displayed in Fig. 4.1. T_{zz} denotes the zz -Cauchy stress component and $l = l(t)$, l_0 are the lengths of the bar in z -direction at time t and at the beginning of the deformation process, respectively. It can be seen that there exist only small quantitative differences between the predicted responses. This was the reason for choosing the material parameters as above.

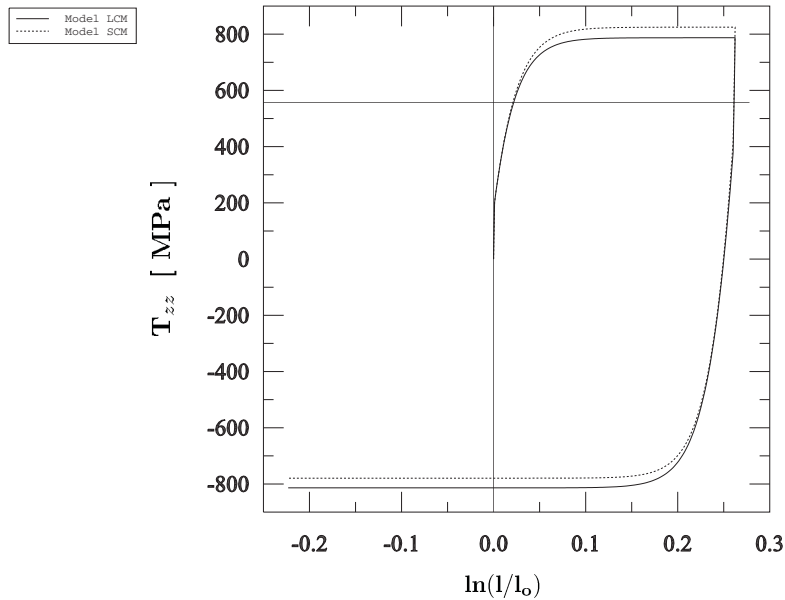

Figure 4.1: Uniaxial homogenous tension-compression loadings of a bar in the z -direction.

4.5.2 Tension-compression loading of a notched circular specimen

Strain controlled inhomogenous tension-compression loading can be generated by a notched circular cylinder specimen. The mantle of the specimen is taken to be traction-free, whereas the top boundaries are first elongated by the action of tension, resulting to a global strain ε of about 15%. Subsequently, the top boundaries of the specimen have been compressed, resulting in a global compression strain ε of about -15% . Taking into account various symmetry conditions, a quarter of such a specimen is illustrated in Fig. 4.2. We denote the radius of the notch by ϱ ; R_0 is the maximal outer radius and R_{on} is the minimal outer radius (radius in the plane through the notch root) of the specimen. Using cylindrical polar coordinates (R, Φ, Z) and (r, φ, z) in the undeformed and current configuration, respectively, we have $0 \leq R \leq R_0$, $-L_0 \leq Z \leq L_0$ and $-L(t) \leq z \leq L(t)$ with $L(t=0) = L_0$. The geometry of the specimen is specified by $L_0 = 80$ mm, $\rho = 4$ mm and $R_{on} = 6$ mm, while the finite element mesh is build up of 244 8-node axisymmetric elements with reduced integration (CAX8R) and 809 nodes. The discretization of the critical radius in the plane through the notch root ($Z = 0$) involves 19 equidistant located nodes.

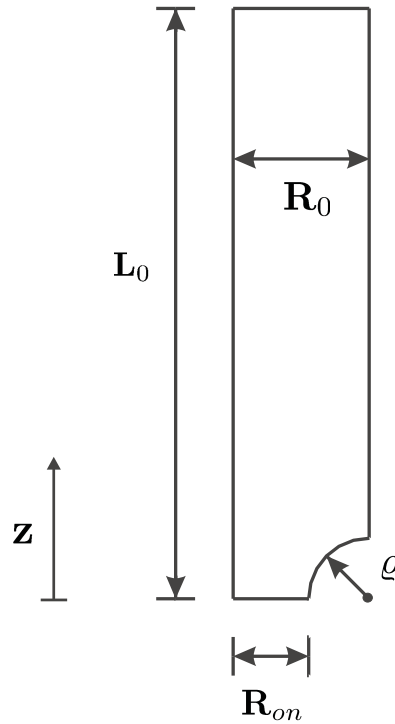

Figure 4.2: A quarter of a notched circular specimen.

Radial distributions of the stress components T_{rr} , $T_{\varphi\varphi}$ and T_{zz} , in the plane through the notch root ($Z = 0$), are illustrated in Figs. 4.3–4.5 for monotonic tensile loading and $\varepsilon = 15\%$, and in Figs. 4.6–4.8 for tension-compression loading and $\varepsilon = -15\%$. It turns out that all distributions are similar with small quantitative differences.

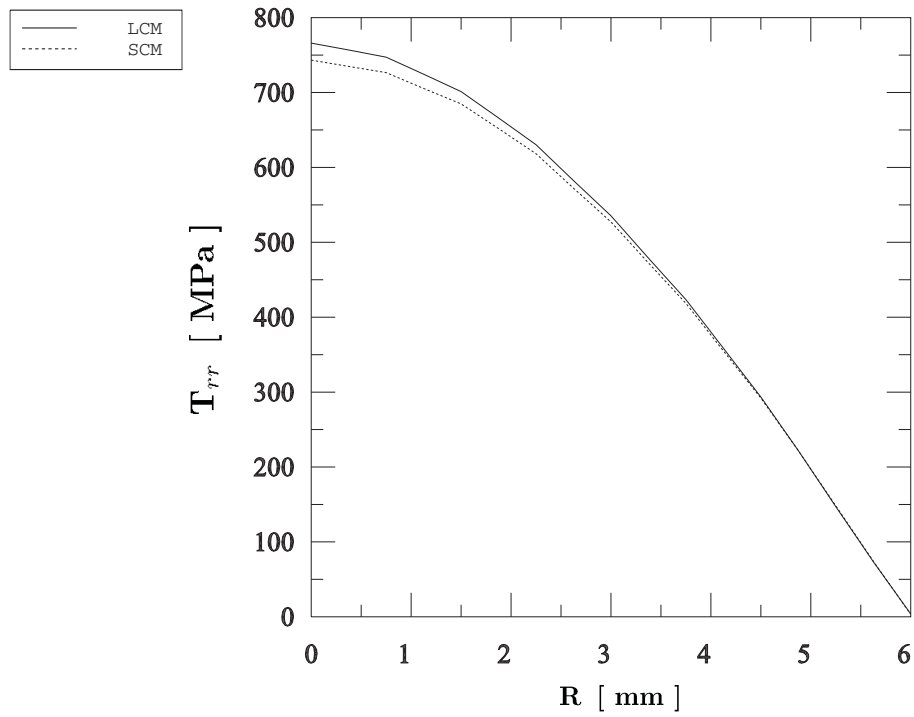

Figure 4.3: Monotonic tensile loading. T_{rr} stress components in the notch root at $\varepsilon = 15\%$.

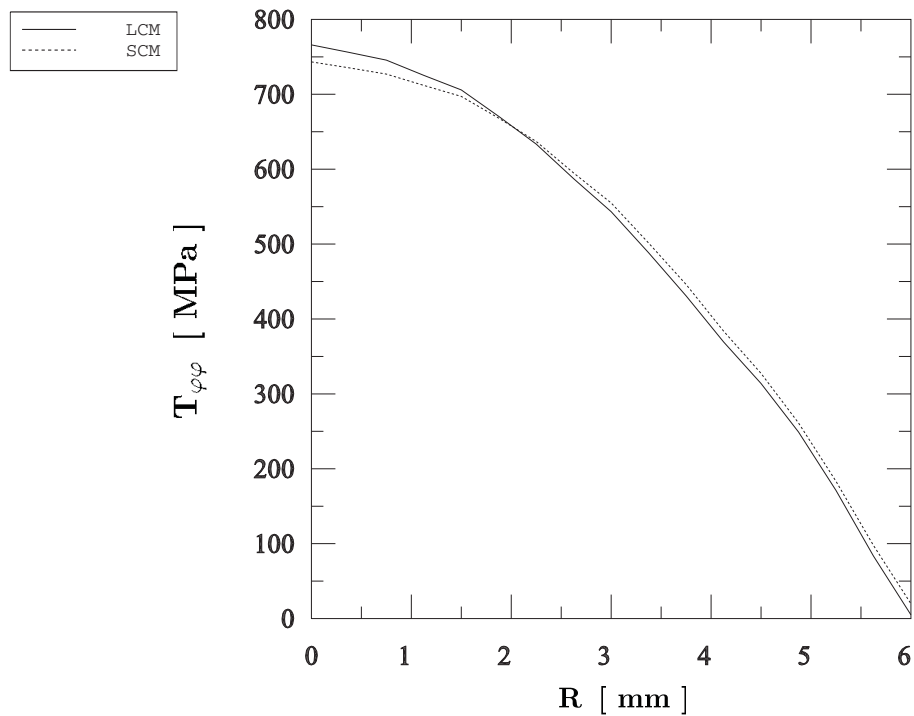

Figure 4.4: Monotonic tensile loading. $T_{\varphi\varphi}$ stress components in the notch root at $\varepsilon = 15\%$.

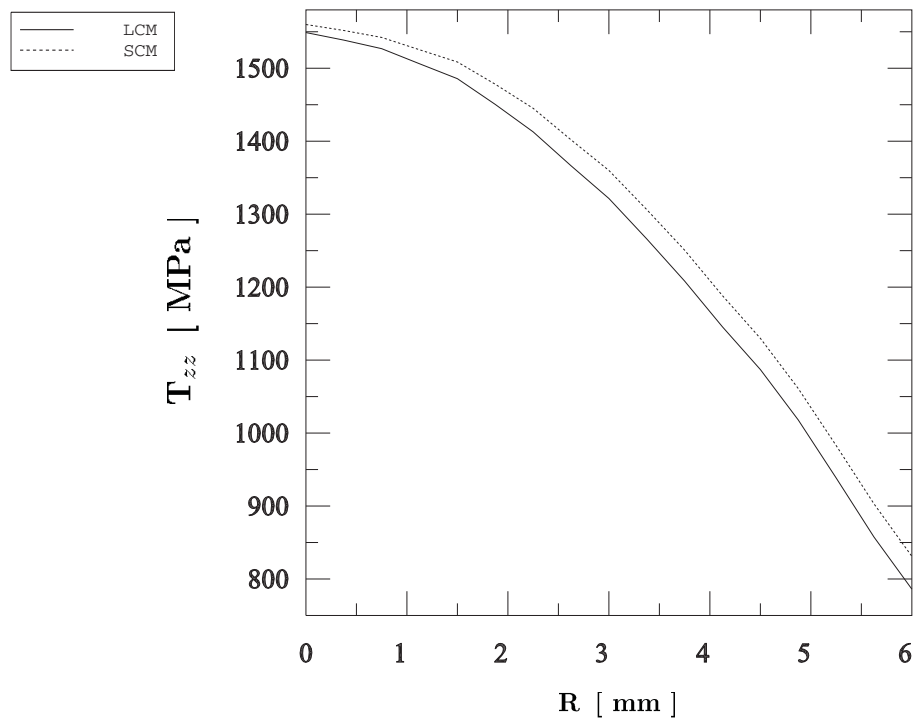

Figure 4.5: Monotonic tensile loading. T_{zz} stress components in the notch root at $\varepsilon = 15\%$.

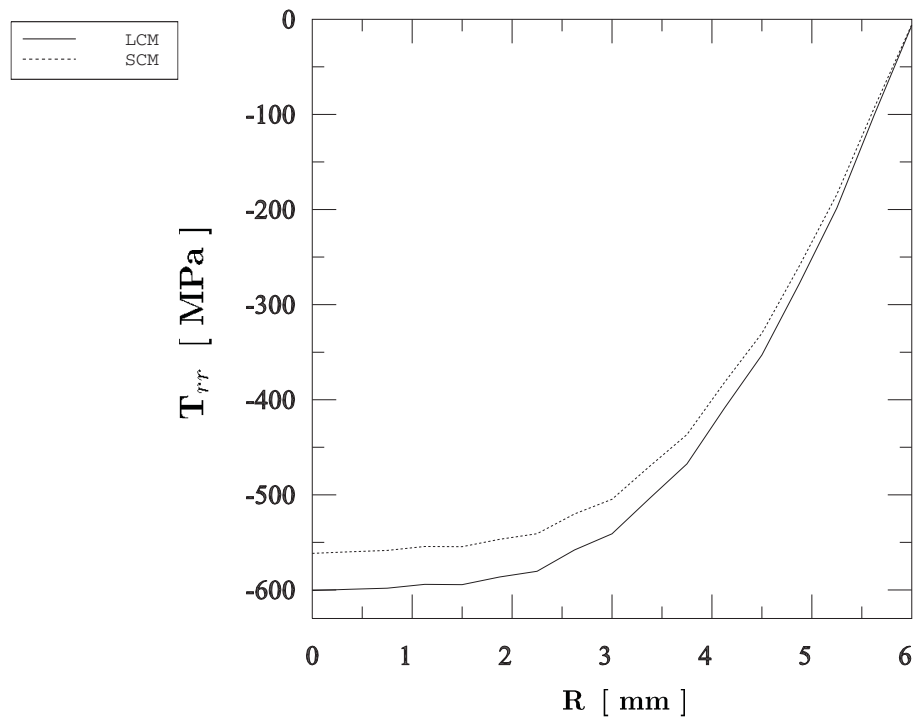

Figure 4.6: Tension-compression loading. T_{rr} stress components in the notch root at $\varepsilon = -15\%$.

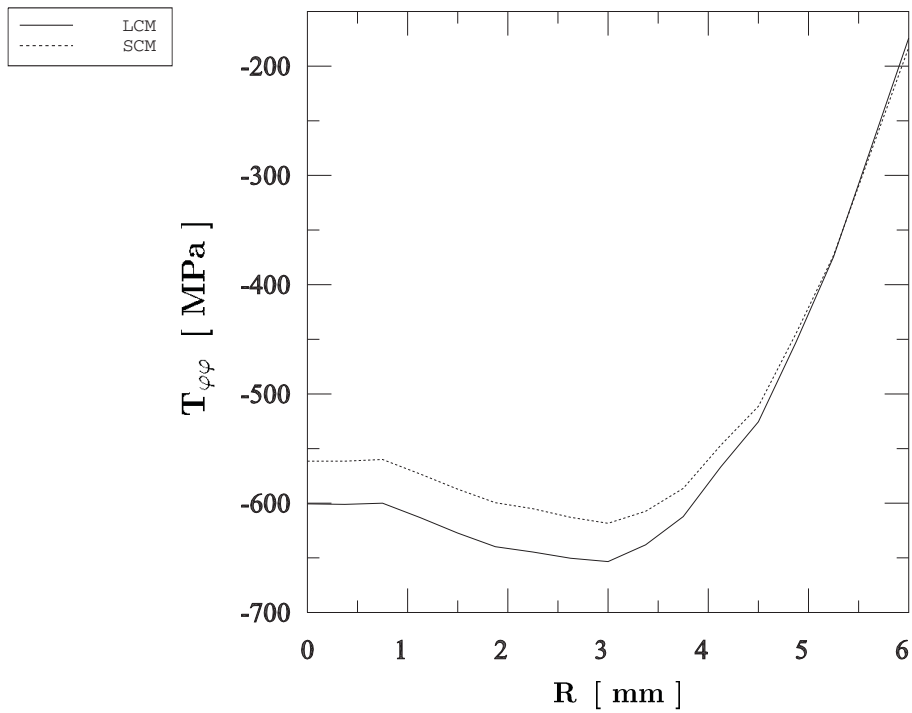

Figure 4.7: Tension-compression loading. $T_{\varphi\varphi}$ stress components in the notch root at $\varepsilon = -15\%$.

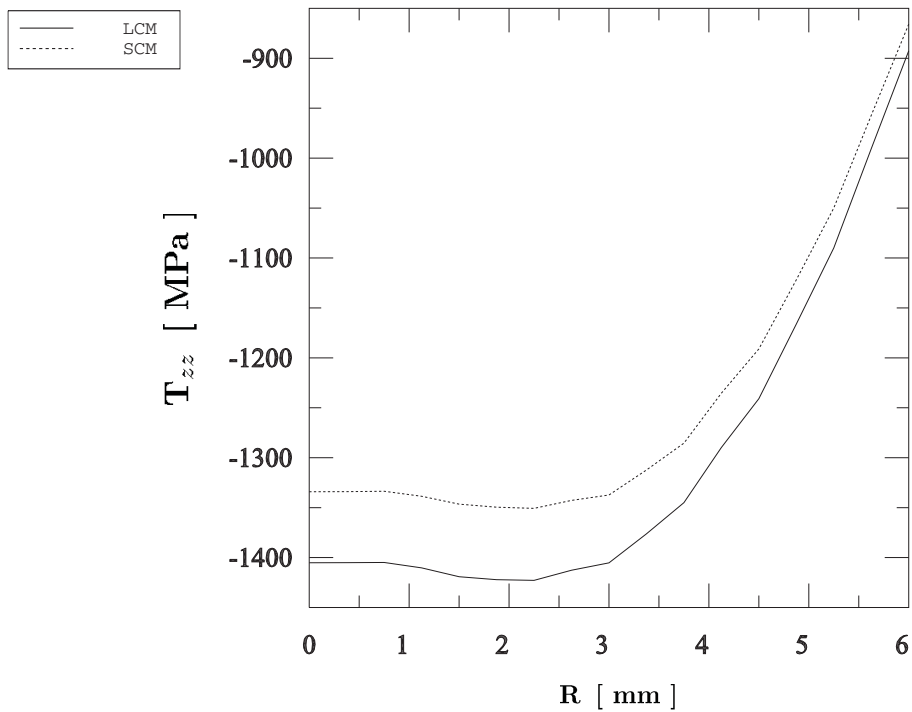

Figure 4.8: Tension-compression loading. T_{zz} stress components in the notch root at $\varepsilon = -15\%$.

4.5.3 Simple Shear

Simple shear represents a homogenous deformation which involves large amounts of rotation. With respect to Cartesian coordinates (x, y, z) , the deformation gradient tensor \mathbf{F} is given by

$$\mathbf{F}_{ij}(t) = \begin{pmatrix} 1 & \gamma(t) & 0 \\ 0 & 1 & 0 \\ 0 & 0 & 1 \end{pmatrix}. \quad (4.33)$$

The shear strain γ is given by $\gamma = \tan \Theta$, where $\Theta = \Theta(t)$ is the angle of shear in the (x, y) -coordinate plane (see Fig. 4.9).

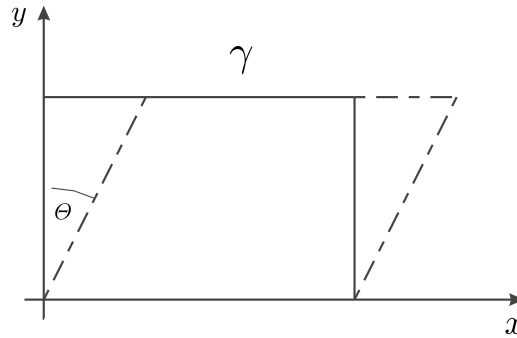

Figure 4.9: Simple shear.

Consider the loading history, where γ is increasing at the beginning until the value 0.5 is reached (loading), and then decreases to the value of -0.3 (reloading). The corresponding stress distributions against γ are displayed in Figs. 4.10–4.13. Whereas the γ - T_{xy} plots are in principle identical, the two models indicate quantitative and qualitative differences with respect to the second-order effects, i.e., relative to the plots of the normal stresses. The γ - T_{xx} and γ - T_{yy} plots are similar, but some quantitative differences are existing. Quantitative as well as qualitative differences are present in the predicted γ - T_{zz} responses. In particular the T_{zz} stress components are characterized by different signs. Note that the normal stress components for both models, compared with the shear stress component T_{xy} , are smaller of about one order of magnitude.

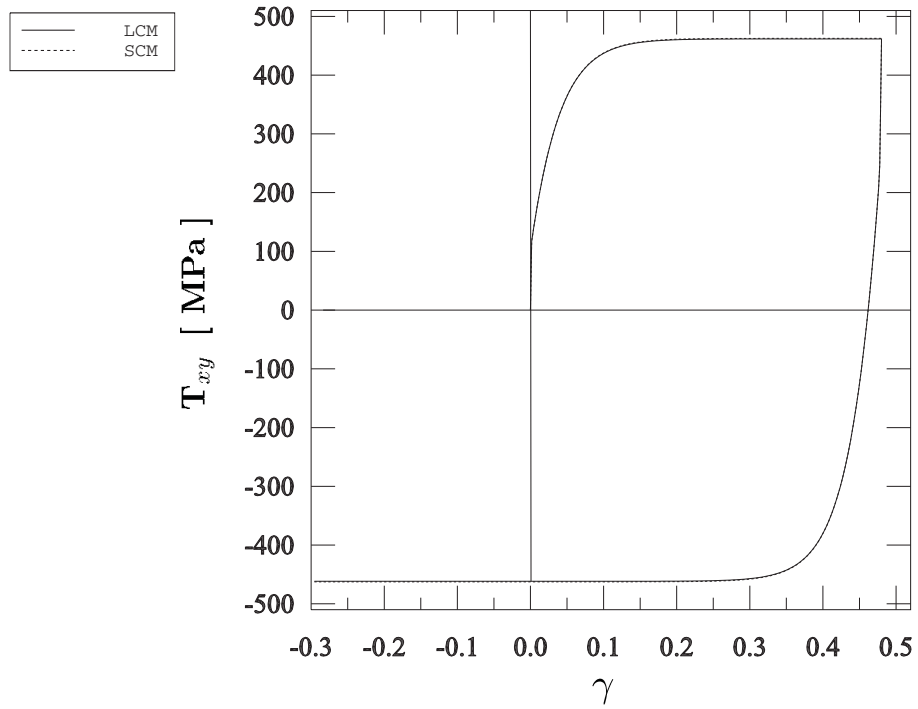

Figure 4.10: Calculated values of the shear stress T_{xy} .

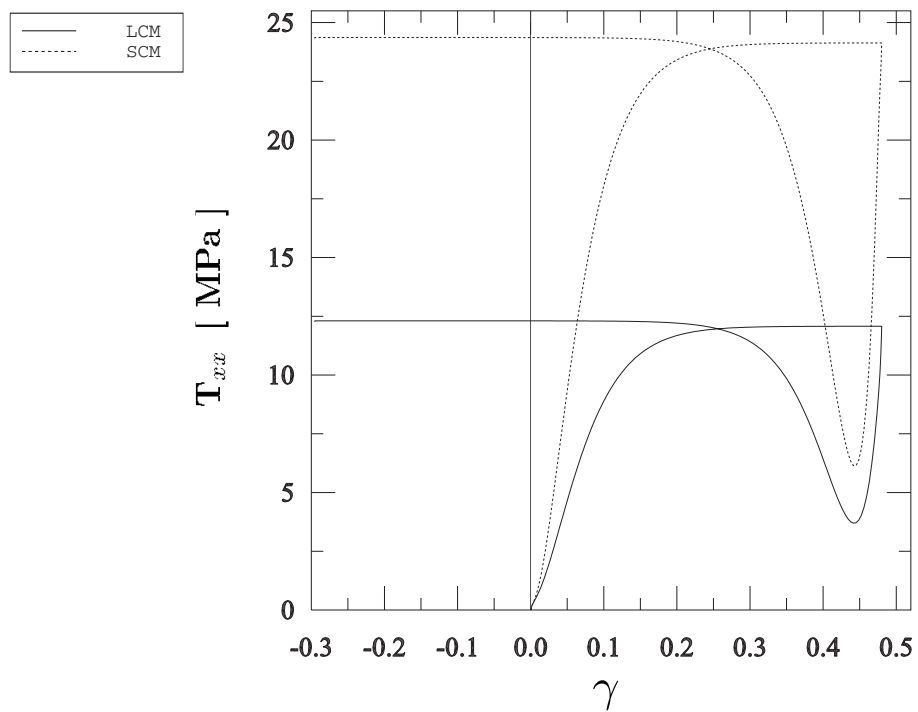
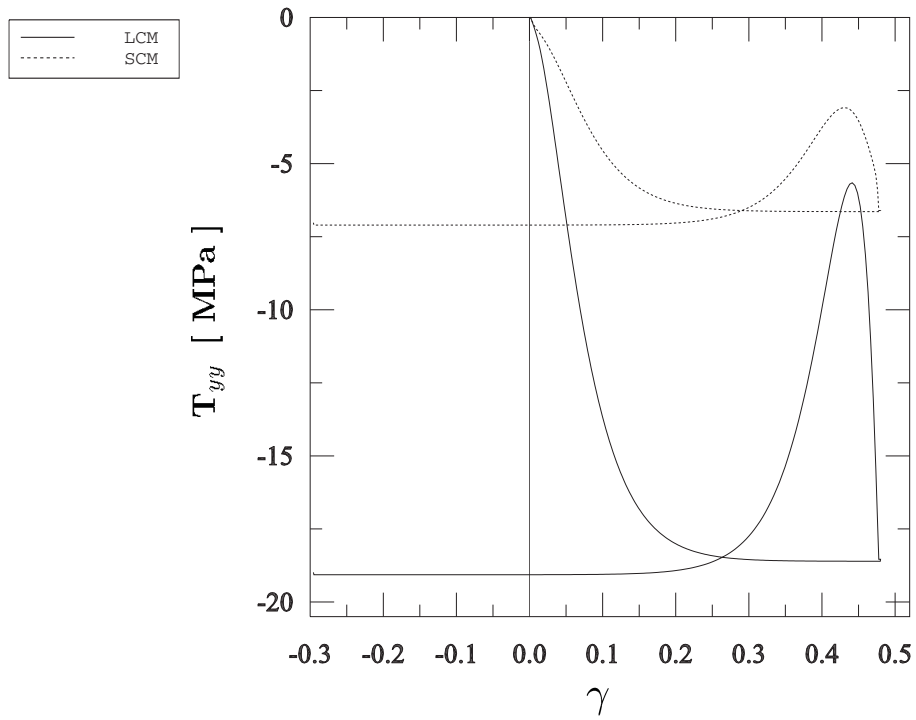
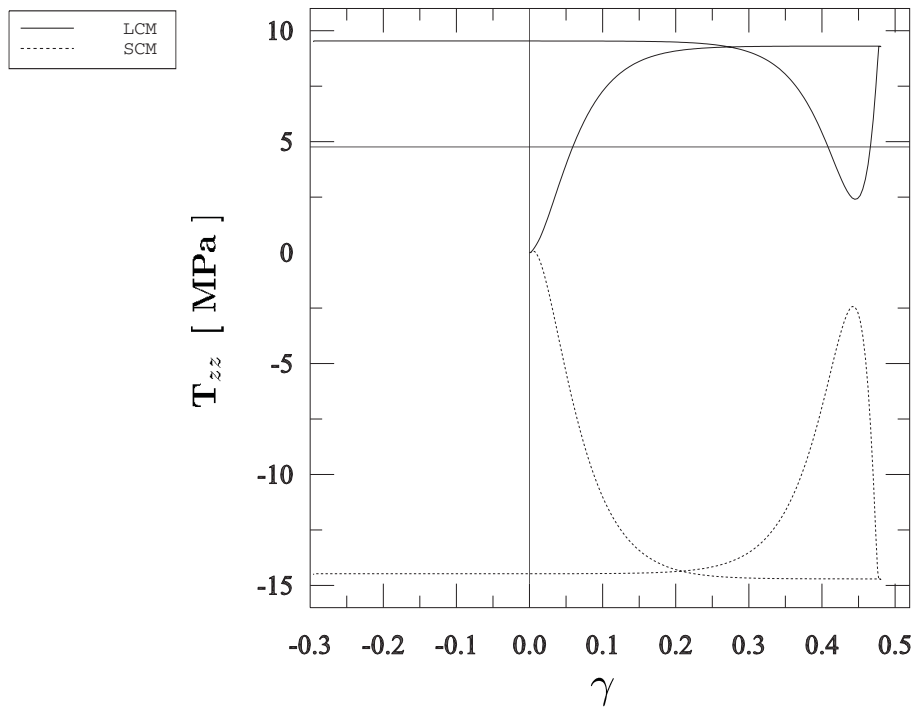

Figure 4.11: Calculated values of the shear stress T_{xx} .

Figure 4.12: Calculated values of the shear stress T_{yy} .Figure 4.13: Calculated values of the shear stress T_{zz} .

4.5.4 Torsional loading

We consider torsional loading of a circular cylinder with fixed ends. The finite element discretization consists of 75 8-node axisymmetric elements (ABAQUS type CGAX8) and 266 nodes. The outer radius r_0 and the length l of the cylinder are chosen to be equal to 0.85 mm. The discretization of the radius involves 31 nodes.

From classical finite deformation elasticity and plasticity it is well known (see, e.g., [127, 91, 165, p. 306]) that for realizing torsional loading with constant length some axial (compression) forces are required to act on the ends of the specimen. This so-called second-order effect is known in the elasticity theory as Poynting-effect. Particularly, a non-constant r - T_{zz} distribution is necessary in general. In the case of classical plasticity, where the yield function is an isotropic function of its arguments, axial normal stresses are required whenever kinematic hardening is invoked.

All radial distributions of stress components according to the two models, except of the axial stress component T_{zz} , are essentially identical. Consequently, we concentrate ourselves on the predicted r - T_{zz} responses ($0 \leq r \leq r_0$) displayed in Figs. 4.14 and 4.15. In these Figures, $\gamma = \vartheta r_0$ is the global shear of the cylinder (shear at the outer radius), where ϑ is the twist per unit length. It can be seen that for sufficient large amount of shear the maxima of the graphs are at $r = 0$ for LCM and at $r = r_0$ for SCM (more details may be found in [140, 68]). Moreover, at the neighborhood of the minimum the stress distributions for SCM indicate large amounts of gradients. Thus, significant qualitative differences in the predicted responses are present in the r - T_{zz} graphs. It is worth emphasizing that, as in the case of simple shear, the axial stress components, compared with the shear stress components, are of about one order of magnitude smaller.

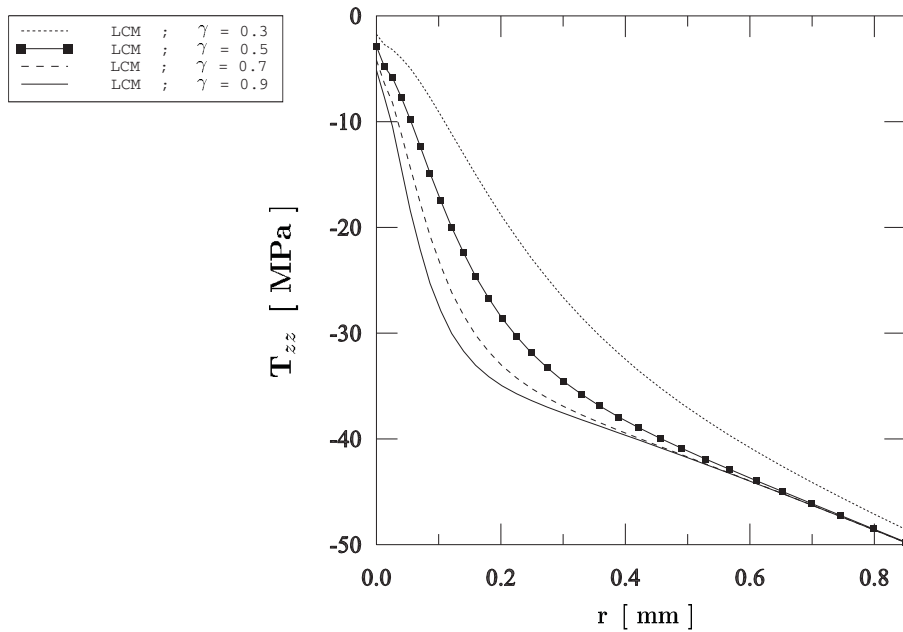

Figure 4.14: Calculated values of the normal stress T_{zz} .

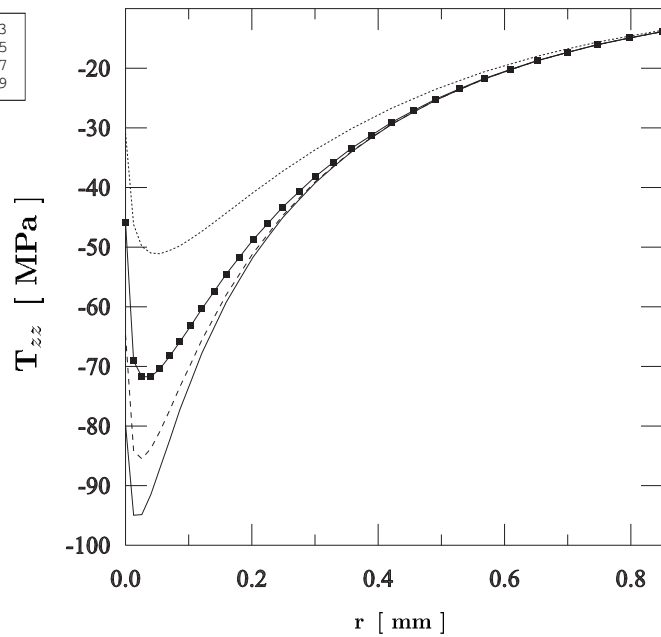

Figure 4.15: Calculated values of the normal stress T_{zz} .

4.6 Concluding remarks

The limiting classical model is characterized by a kinematic hardening law, which is expressed in terms of non-symmetric internal strain and stress tensors. In particular, a mixed Oldroyd time derivative is involved. As mentioned above, standard classical models deal with symmetric internal strain tensors responsible for kinematic hardening. For such models evolution equations involving both, the upper and the lower Oldroyd time derivatives, in connection with back-stress tensors of Mandel type have already been investigated (see, e.g., [157, 162]). It has been recognized, that the main differences occur in the predicted second-order effects. Therefore, it is natural to expect that for different kinematic hardening models, including the limiting classical model considered, the most important differences in predicted responses will be present in second-order effects. Indeed, the investigations here confirm this supposition. To complete the investigation of kinematic hardening rules on the basis of Oldroyd time derivatives, it remains still to discuss the other mixed Oldroyd time derivative. Also, it is of interest to find the corresponding micropolar plasticity model. However, the answer of such questions is beyond of the scope of the present paper and will be tackled in a future work.

5 Isotropic hardening in micropolar plasticity

P. Grammenoudis, Ch. Tsakmakis

**Archive of Applied Mechanics (Ingenieur Archiv),
79 (2009) 4, 323-334**

Isotropic hardening in micropolar plasticity

P. Grammenoudis, Ch. Tsakmakis

**Darmstadt University of Technology, Institute of Continuum Mechanics,
Hochschulstraße 1, 64289 Darmstadt, Germany**

Abstract

Experimental evidence for length scale effects in plasticity has been provided, e.g., by Fleck et al. [50]. Results from torsional loadings on copper wires, when appropriately displayed, indicated that, for the same shear at the outer radius, the normalized torque increased with decreasing specimen radius. Modelling of the constitutive behavior in the framework of micropolar plasticity is a possibility to account for length scale effects. The present paper is concerned with this possibility and deals with the theory developed by Grammenoudis and Tsakmakis [67, 69, 70]. Both isotropic and kinematic hardening are present in that theory, with isotropic hardening being captured in a unified manner. Here, we discuss isotropic hardening composed of two parts, responsible for strain and gradient effects, respectively.

5.1 Introduction

It has been recognized experimentally (see, for example, Stelmashenko [151], Fleck et al. [50], Ma and Clarke [115], Poole et al. [135], Stölken and Evans [152]) that materials exhibit strong size effects when characteristic macroscopic dimensions are comparable with some internal length scales inherent to the material behavior. For metals, such effects are in essence observable once plastic deformations have been produced. In order to capture size effects, one has to introduce in some way nonlocality aspects into the constitutive equations governing the response of plastically deformable solids. This may be achieved, for example, by including higher-order gradients of the kinematical and dynamical variables (see, for example, Aifantis [3, 4, 5], Fleck and Hutchinson [51, 52], Toupin [154], Mindlin and Tiersten [123], Mindlin [122], Eringen and Suhubi [49], Eringen [45, 46]).

One particular type of "gradient" theory is the micropolar model, which has been discussed by Eringen [45, 46] and is closely related to the Cosserat continuum [30]. Micropolar models display the property that the Cauchy stress tensor is no longer symmetric and that so-called couple-stress tensors are present, which are thermodynamically conjugate to micropolar curvature tensors. The latter are expressed in terms of the spatial gradient of a microrotation tensor, which is invoked to augment the kinematical degrees of freedom at every material point. In phenomenological plasticity, micropolar theories have been proposed, investigated, and applied by Lippmann [109], Diepolder et al. [37], Besdo [8], and Steinmann [149]. Micropolar crystal plasticity models have been developed by Forest [54] and Forest et al. [53], while Ehlers and Volk [43] made use of micropolar theories to describe constitutive properties of porous media. Moreover, micropolar theories have been employed by de Borst [10], de

Borst and Mühlhaus [12], Dietsche and Willam [38], Tejchman and Wu [153], Mühlhaus and Vardoulakis [118], Steinmann [149], and Steinmann and Willam [150] to study strain-softening material response and related localization phenomena in the framework of rate-independent plasticity.

A constitutive model for finite-deformations micropolar plasticity exhibiting kinematic and isotropic hardening in a thermodynamically consistent way has been proposed by Grammenoudis and Tsakmakis [67, 69, 70]. While kinematic hardening addresses separately effects due to strain and rotation gradients, isotropic hardening in these papers was unified formulated, i.e., the influence of strain and rotation gradient terms on isotropic hardening is not accounted for separately. In particular, the material parameters governing isotropic hardening may be identified from purely homogeneous uniaxial tensile experiments. It has been concluded in Grammenoudis and Tsakmakis [70] that such isotropic hardening rules overestimates the aforementioned experimental results concerning torsional loading, and therefore fail to predict generally the material response appropriately. In contrast, the kinematic hardening rule allows a more accurate fit to the experimental results. Hence, the question arises of when it is possible to predict appropriately the experimental responses for monotonic torsional loading by assuming an isotropic hardening law which accounts separately for effects due to strain and rotations gradients. This question is properly discussed in the present paper by means of parameter studies. As it will be shown, the isotropic hardening proposed herein, which is thermodynamically consistent, is essentially capable to predict appropriately the experimental results. To estimate the capabilities of the model on the basis of fitted material parameters is beyond the scope of the present work, as the currently available numerical approaches take large amounts of time.

5.2 The micropolar plasticity model

Micropolar theories use as independent kinematical variables the deformation gradient tensor \mathbf{F} and the so-called micropolar rotation tensor $\bar{\mathbf{R}}$. Multiplicative decomposition of \mathbf{F} into elastic and plastic parts for classical plasticity has been assumed by Lee (see, e.g., Lee and Liu [101] and Lee [100]). For micropolar plasticity, multiplicative decompositions of \mathbf{F} and $\bar{\mathbf{R}}$, into elastic and plastic parts respectively, were postulated by Steinmann [149]:

$$\mathbf{F} = \mathbf{F}_e \mathbf{F}_p \quad , \quad \bar{\mathbf{R}} = \bar{\mathbf{R}}_e \bar{\mathbf{R}}_p \quad . \quad (5.1)$$

Geometrically, \mathbf{F}_p and $\bar{\mathbf{R}}_p$ introduce a so-called plastic intermediate configuration, denoted by \hat{R}_t . Based on Eqs. (5.1), a thermodynamically consistent micropolar plasticity theory has been proposed by Grammenoudis and Tsakmakis [67]. Focussing attention on isotropic hardening only, and using the notation introduced in [67], the most relevant constitutive relations of that theory, relative to the plastic intermediate configuration, are given as follows.

Kinematics:

$$\mathbf{F} = \mathbf{R}\mathbf{U} = \mathbf{V}\mathbf{R} \quad , \quad \mathbf{F}_e = \mathbf{R}_e \mathbf{U}_e = \mathbf{V}_e \mathbf{R}_e \quad , \quad \mathbf{F}_p = \mathbf{R}_p \mathbf{U}_p = \mathbf{V}_p \mathbf{R}_p \quad , \quad (5.2)$$

$$\mathbf{F} = \bar{\mathbf{R}}\bar{\mathbf{U}} = \bar{\mathbf{V}}\bar{\mathbf{R}} \quad , \quad \mathbf{F}_e = \bar{\mathbf{R}}_e \bar{\mathbf{U}}_e = \bar{\mathbf{V}}_e \bar{\mathbf{R}}_e \quad , \quad \mathbf{F}_p = \bar{\mathbf{R}}_p \bar{\mathbf{U}}_p = \bar{\mathbf{V}}_p \bar{\mathbf{R}}_p \quad , \quad (5.3)$$

$$\hat{\mathbf{L}}_p = \dot{\mathbf{F}}_p \mathbf{F}_p^{-1} \quad , \quad \hat{\mathbf{D}}_p = \frac{1}{2}(\hat{\mathbf{L}}_p + \hat{\mathbf{L}}_p^T) \quad , \quad \hat{\mathbf{W}}_p = \frac{1}{2}(\hat{\mathbf{L}}_p - \hat{\mathbf{L}}_p^T) \quad , \quad \hat{\mathbf{\Omega}}_p = \dot{\bar{\mathbf{R}}}_p \bar{\mathbf{R}}_p^T \quad , \quad (5.4)$$

$$\hat{\mathbf{e}} = \hat{\mathbf{e}}_e + \hat{\mathbf{e}}_p \quad , \quad \hat{\mathbf{e}}_e = \bar{\mathbf{U}}_e - \mathbf{1} \quad , \quad \hat{\mathbf{e}}_p = \mathbf{1} - \bar{\mathbf{V}}_p^{-1} \quad , \quad (5.5)$$

$$\hat{\mathbf{K}} = \hat{\mathbf{K}}_e + \hat{\mathbf{K}}_p = \bar{\mathbf{R}}_p \tilde{\mathbf{K}} \bar{\mathbf{R}}_p^T \quad , \quad \tilde{\mathbf{K}} = \left\{ \text{axl} \left(\bar{\mathbf{R}}^T \frac{\partial \bar{\mathbf{R}}}{\partial X_k} \right) \right\} \otimes \mathbf{E}_k \quad . \quad (5.6)$$

Stress and couple stress tensors:

$$\mathbf{S} = (\det \mathbf{F})\mathbf{T} = \bar{\mathbf{R}}_e \hat{\mathbf{T}} \mathbf{F}_e^T = \mathbf{F}_e \hat{\mathbf{S}} \mathbf{F}_e^T, \quad \hat{\mathbf{P}} = (\mathbf{1} + \hat{\boldsymbol{\epsilon}}_e^T) \hat{\mathbf{T}} = \hat{\mathbf{C}}_e \hat{\mathbf{S}}, \quad (5.7)$$

$$\mathbf{S}_c = (\det \bar{\mathbf{V}}) \mathbf{T}_c \bar{\mathbf{V}}^{T-1} = \bar{\mathbf{R}}_e \hat{\mathbf{T}}_c \bar{\mathbf{R}}_e^T, \quad \hat{\mathbf{P}}_c \equiv \hat{\mathbf{T}}_c. \quad (5.8)$$

Specific free energy:

$$\Psi(t) = \Psi_e(t) + \Psi_p(t). \quad (5.9)$$

Elasticity law:

$$\Psi_e = \hat{\Psi}_e(\hat{\boldsymbol{\epsilon}}_e, \hat{\mathbf{K}}_e), \quad \hat{\mathbf{T}} = \varrho \mathcal{R} \frac{\partial \hat{\Psi}_e}{\partial \hat{\boldsymbol{\epsilon}}_e}, \quad \hat{\mathbf{T}}_c = \varrho \mathcal{R} \frac{\partial \hat{\Psi}_e}{\partial \hat{\mathbf{K}}_e}. \quad (5.10)$$

Yield function:

$$\begin{aligned} f(t) &= \hat{f}(\hat{\mathbf{P}}, \hat{\mathbf{P}}_c, \hat{\boldsymbol{\xi}}, \hat{\boldsymbol{\xi}}_c, k) \\ &= \left\{ (\alpha_1 + \alpha_2) \hat{\mathbf{P}}^D \cdot \hat{\mathbf{P}}^D + (\alpha_1 - \alpha_2) \hat{\mathbf{P}}^D \cdot (\hat{\mathbf{P}}^T)^D \right. \\ &\quad \left. + (\alpha_3 + \alpha_4) \hat{\mathbf{P}}_c^D \cdot \hat{\mathbf{P}}_c^D + (\alpha_3 - \alpha_4) \hat{\mathbf{P}}_c^D \cdot (\hat{\mathbf{P}}_c^T)^D \right\}^{\frac{1}{2}} - k, \end{aligned} \quad (5.11)$$

$$k = R + h, \quad h = \text{const.} \geq 0. \quad (5.12)$$

Flow rules:

$$\overset{\diamond}{\hat{\boldsymbol{\epsilon}}}_p = \dot{\hat{\boldsymbol{\epsilon}}}_p - \hat{\boldsymbol{\Omega}}_p \hat{\boldsymbol{\epsilon}}_p + \hat{\boldsymbol{\epsilon}}_p \hat{\mathbf{L}}_p \equiv \hat{\mathbf{L}}_p - \hat{\boldsymbol{\Omega}}_p = \frac{\dot{s}}{\zeta} \frac{\partial \hat{f}}{\partial \hat{\mathbf{P}}}, \quad (5.13)$$

$$\overset{\diamond}{\hat{\mathbf{K}}}_p = \dot{\hat{\mathbf{K}}}_p - \hat{\boldsymbol{\Omega}}_p \hat{\mathbf{K}}_p - \hat{\mathbf{K}}_p \hat{\boldsymbol{\Omega}}_p^T = \frac{\dot{s}}{\zeta} \frac{\partial \hat{f}}{\partial \hat{\mathbf{P}}_c}, \quad (5.14)$$

$$\dot{s} := \sqrt{\overset{\diamond}{\hat{\boldsymbol{\epsilon}}}_p \cdot \overset{\diamond}{\hat{\boldsymbol{\epsilon}}}_p + \overset{\diamond}{\hat{\mathbf{K}}}_p \cdot \overset{\diamond}{\hat{\mathbf{K}}}_p} = \sqrt{\dot{s}_1^2 + \dot{s}_2^2}, \quad (5.15)$$

$$\dot{s}_1 = \sqrt{\overset{\diamond}{\hat{\boldsymbol{\epsilon}}}_p \cdot \overset{\diamond}{\hat{\boldsymbol{\epsilon}}}_p}, \quad \dot{s}_2 = \sqrt{\overset{\diamond}{\hat{\mathbf{K}}}_p \cdot \overset{\diamond}{\hat{\mathbf{K}}}_p}, \quad (5.16)$$

$$\zeta := \sqrt{\frac{\partial \hat{f}}{\partial \hat{\mathbf{P}}} \cdot \frac{\partial \hat{f}}{\partial \hat{\mathbf{P}}} + \frac{\partial \hat{f}}{\partial \hat{\mathbf{P}}_c} \cdot \frac{\partial \hat{f}}{\partial \hat{\mathbf{P}}_c}}. \quad (5.17)$$

In these relations, plastic incompressibility is assumed to apply, so that $\det \mathbf{F}_p = 1$ or $\text{tr} \hat{\mathbf{L}}_p = 0$. While Eqs. (5.2) represent polar decompositions, this is not the case for Eqs. (5.3). It is important to notice that the second-order tensors $\bar{\mathbf{U}}, \bar{\mathbf{V}}, \bar{\mathbf{U}}_e, \bar{\mathbf{V}}_e, \bar{\mathbf{U}}_p$ and $\bar{\mathbf{V}}_p$ do not represent symmetric tensors generally. The micropolar strains $\hat{\boldsymbol{\epsilon}}, \hat{\boldsymbol{\epsilon}}_e$ and $\hat{\boldsymbol{\epsilon}}_p$ and the so-called micropolar curvatures $\hat{\mathbf{K}}, \hat{\mathbf{K}}_e$ and $\hat{\mathbf{K}}_p$ are second-order tensors, which are generally nonsymmetric. \mathbf{T} and \mathbf{T}_c are the Cauchy stress tensor and the Eulerian couple stress tensor, respectively. These stresses enter into the balance laws of momentum

and moment of momentum, which are not considered here. $\hat{\mathbf{P}}$ and $\hat{\mathbf{P}}_c$ denote so-called Mandel stress and Mandel couple stress tensors, respectively. The specific free energy Ψ in Eq. (5.9) is additively composed of parts responsible for elasticity and isotropic hardening. Furthermore, Ψ is stipulated to be an isotropic tensor function of its arguments. The yield function in Eq. (5.11) represents a finite deformation counterpart of a yield function for small deformations proposed by de Borst [11] with $\alpha_1, \alpha_2, \alpha_3$ and α_4 , being material parameters. In this, k is the yield stress and h denotes a material parameter. Isotropic hardening is modelled by the scalar stress like variable R . If the value of R at the beginning of the deformation process is assumed to vanish, then h represents the initial yield stress. The flow rules are associated normality rules, derived as sufficient conditions for the validity of Il'iusin's postulate extended to micropolar materials.

It is important to notice that $\hat{\mathbf{K}}_p$ in Grammenoudis and Tsakmakis [67] is related to some gradient terms relative to the reference configuration and hence should satisfy some kind of compatibility conditions, but such compatibility conditions are not regarded in [67]. Therefore, strictly speaking, that constitutive theory is wrong. However, one can define $\hat{\mathbf{K}}_p$ to be only a linear map, which otherwise fullfills the same transformations conditions as $\hat{\mathbf{K}}_p$ in [67]. Then, the constitutive theory developed in Grammenoudis and Tsakmakis [67] will be correct, and this version is adopted here.

In Grammenoudis and Tsakmakis [67] isotropic hardening is governed by the Eqs.

$$\Psi_p^{(is)} = \hat{\Psi}_p^{(is)}(r) = \frac{1}{\varrho\mathcal{R}} \left(\frac{1}{2} \gamma^{is} r^2 + R_0 r \right) \quad , \quad (5.18)$$

$$R := \varrho\mathcal{R} \frac{\partial \hat{\Psi}_p^{(is)}}{\partial r} = \gamma^{is} r + R_0 \quad , \quad (5.19)$$

$$R_0 = R|_{s=0} \quad , \quad k_0 := k|_{s=0} = R_0 + h \quad , \quad (5.20)$$

$$\dot{r} = (1 - \beta^{is} r) \frac{\dot{s}}{\zeta} \quad , \quad r|_{s=0} = 0 \quad , \quad (5.21)$$

where the quantities β^{is} , γ^{is} , and R_0 denote material parameters. This form of isotropic hardening rule resamples those for classical plasticity intensively investigated by Chaboche [19, 20]. It may be recognized that the isotropic hardening model (5.18)–(5.21) reflects effects of micropolar strains and curvatures in a unified manner. Indeed, \dot{r} in (5.21) depends on the increment of the plastic arc length \dot{s} , which in turn is a function of both $\hat{\epsilon}_p^\diamond$ and $\hat{\mathbf{K}}_p^\diamond$ (see Eq. (5.15)).

5.3 Isotropic hardening accounting separately for strain and rotation gradient effects

The aim of the present paper is to propose an isotropic hardening rule accounting separately for strain and rotation gradient effects.

As shown in Grammenoudis and Tsakmakis [67], in the absence of kinematic hardening the internal dissipation inequality reads

$$\mathcal{D}_{int} := \hat{\mathbf{P}} \cdot \hat{\epsilon}_p^\diamond + \hat{\mathbf{P}}_c \cdot \hat{\mathbf{K}}_p^\diamond - \varrho\mathcal{R} \dot{\Psi}_p^{is} \geq 0 \quad . \quad (5.22)$$

We shall derive evolution equations for the isotropic hardening response as necessary conditions for the validity of the dissipation inequality (5.22).

The model for isotropic hardening adopted in [67] assumes Ψ_p^{is} to be a function of one scalar variable r . Now, to account separately for strain and rotation gradient effects, Ψ_p^{is} is chosen to be function of two scalar strains r_1 and r_2

$$\Psi_p^{is} = \hat{\Psi}_p^{is}(r_1, r_2) = \frac{1}{\varrho_{\mathcal{R}}} \left(\frac{1}{2} \gamma_1^{is} r_1^2 + \frac{1}{2} \gamma_2^{is} r_2^2 + R_{01} r_1 + R_{02} r_2 \right) , \quad (5.23)$$

where r_1 and r_2 are, respectively, responsible for strain and rotation gradient effects, and R_{01} , R_{02} , γ_1^{is} , and γ_2^{is} denote nonnegative material parameters.

Following the concepts of irreversible thermodynamics, we introduce thermodynamically conjugate forces by

$$R_1 := \varrho_{\mathcal{R}} \frac{\partial \hat{\Psi}_p^{is}}{\partial r_1} = \gamma_1^{is} r_1 + R_{01} , \quad (5.24)$$

$$R_2 := \varrho_{\mathcal{R}} \frac{\partial \hat{\Psi}_p^{is}}{\partial r_2} = \gamma_2^{is} r_2 + R_{02} . \quad (5.25)$$

With the relation

$$R = R_1 + R_2 , \quad (5.26)$$

the scalar variable k (see Eq. (5.12)), characteristic for isotropic hardening, is then defined through

$$k = R_1 + R_2 + h , \quad (5.27)$$

with

$$k_0 := k|_{s=0} = R_{01} + R_{02} + h . \quad (5.28)$$

Using the material time derivative of (5.23) and Eqs. (5.24) and (5.25), the dissipation inequality (5.22) can be rewritten as

$$\mathcal{D}_{int}^{is} = \hat{\mathbf{P}} \cdot \overset{\diamond}{\hat{\boldsymbol{\epsilon}}}_p + \hat{\mathbf{P}}_c \cdot \overset{\diamond}{\hat{\mathbf{K}}}_p - R_1 \dot{r}_1 - R_2 \dot{r}_2 \geq 0 . \quad (5.29)$$

Making use of the yield function (5.11) and the normality rule (5.13) and (5.14), the dissipation inequality (5.29) is equivalent to

$$\dot{s} \frac{k}{\zeta} - R_1 \dot{r}_1 - R_2 \dot{r}_2 \geq 0 . \quad (5.30)$$

In view of (5.27), Eq. (5.30) reads

$$\frac{\dot{s} R_1}{\zeta} + \frac{\dot{s} R_2}{\zeta} - R_1 \dot{r}_1 - R_2 \dot{r}_2 + \frac{\dot{s} h}{\zeta} \geq 0 . \quad (5.31)$$

From Eqs. (5.15) and (5.16) one can see that the increment of plastic arc length can be split up into two parts corresponding to strain and micropolar curvature. Note that, if kinematic hardening is also involved, the evolution Eqs. related to micropolar strain and rotation can be rewritten with \dot{s}_1 and \dot{s}_2 instead of \dot{s} , respectively. (For a detailed treatment of kinematic hardening, see Grammenoudis and

Tsakmakis [67].) Keeping in mind (5.27), and since $\dot{s}^2 = \dot{s}_1^2 + \dot{s}_2^2$, and therefore $\dot{s} \geq \dot{s}_1$, $\dot{s} \geq \dot{s}_2$, the following rearranged inequality must hold

$$R_1 \left(\frac{\dot{s}_1}{\zeta} - \dot{r}_1 \right) + R_2 \left(\frac{\dot{s}_2}{\zeta} - \dot{r}_2 \right) + \frac{\dot{s}h}{\zeta} \geq 0 \quad . \quad (5.32)$$

Because $\frac{\dot{s}h}{\zeta} \geq 0$, it suffices to require

$$R_1 \left(\frac{\dot{s}_1}{\zeta} - \dot{r}_1 \right) + R_2 \left(\frac{\dot{s}_2}{\zeta} - \dot{r}_2 \right) \geq 0 \quad (5.33)$$

in order to satisfy Eq. (5.22) always. Thus,

$$R_1 \left(\frac{\dot{s}_1}{\zeta} - \dot{r}_1 \right) \geq 0 \quad , \quad R_2 \left(\frac{\dot{s}_2}{\zeta} - \dot{r}_2 \right) \geq 0 \quad (5.34)$$

are sufficient conditions for (5.33). This, in turn, will be satisfied if

$$\frac{\dot{s}_1}{\zeta} - \dot{r}_1 = \beta_1^{is} \frac{\dot{s}_1}{\zeta} R_1 \quad , \quad (5.35)$$

$$\frac{\dot{s}_2}{\zeta} - \dot{r}_2 = \beta_2^{is} \frac{\dot{s}_2}{\zeta} R_2 \quad , \quad (5.36)$$

or equivalently,

$$\dot{r}_1 = (1 - \beta_1^{is} r_1) \frac{\dot{s}_1}{\zeta} \quad , \quad (5.37)$$

$$\dot{r}_2 = (1 - \beta_2^{is} r_2) \frac{\dot{s}_2}{\zeta} \quad , \quad (5.38)$$

where β_1^{is} and β_2^{is} are nonnegative material parameters. Eqs. (5.37) and (5.38) together with the initial conditions

$$r_1|_{s_1=0} = 0 \quad , \quad r_2|_{s_2=0} = 0 \quad , \quad (5.39)$$

represent the evolution law for the isotropic hardening.

In the following section, the capabilities of the isotropic hardening model introduced, which addresses separately strain and rotation gradient effects, will be illustrated with reference to torsional loading. For the field equations and the appropriate boundary conditions a weak form has been established in Grammenoudis and Tsakmakis [69]. This, together with the system of constitutive equations, have been then implemented in the UEL subroutine of the ABAQUS finite element code. The required time integrations are carried out by applying an operator split algorithm of the elastic predictor/plastic corrector type. All the details about the numerical approach employed are reported in [69] and are not repeated here.

5.4 Experimentally observed results for torsional and uniaxial loadings

Fleck et al. [50] performed torsional and uniaxial tension experiments on thin polycrystalline copper wires ranging in diameter $2a$ from 12 to 170 μm . All the wires were annealed, giving grain sizes between

5 and 25 μm . Figure 5.1 displays the measured torsional stresses Q/a^3 as a function of the shear at the outer radius $\gamma_0 = \kappa a$, where Q is the torque and κ is the twist per unit length of the wire. It is argued that the graphs of the stresses Q/a^3 versus κa should coincide if the material response was independent of strain gradients. This was exactly the reason for using the normalized torque in the plots of Fig. 5.1.

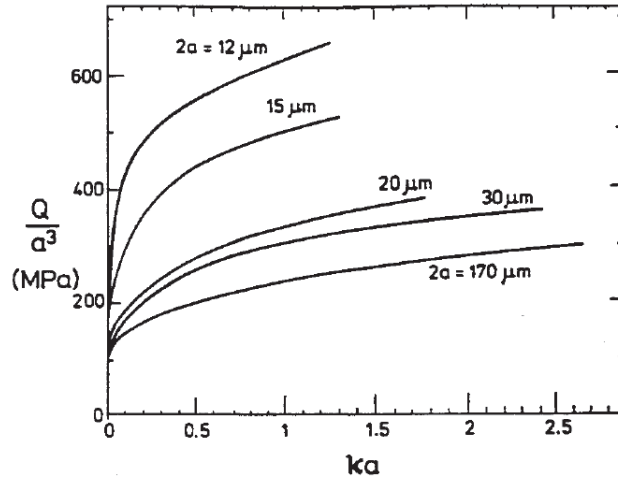

Figure 5.1: Distributions of the normalized torque Q/a^3 as a function of the shear at the outer radius κa according to Fleck et al. [50].

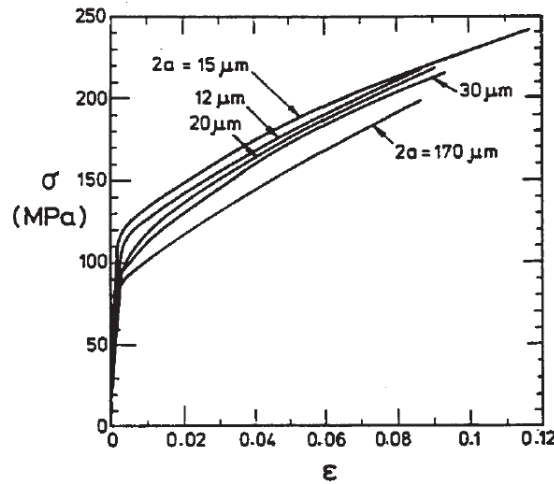

Figure 5.2: Uniaxial tension responses of copper wires, according to Fleck et al. [50], σ : true stress, ε : logarithmic strain.

To exclude other reasons, than strain gradients, Fleck et al. [50] conducted also uniaxial tension tests on copper wires. The measured stress versus strain distributions are shown in Fig. 5.2. The authors concluded that there is only a negligible influence of wire diameter on the tensile behavior. This confirms the fact that in uniaxial tension strain gradients are vanishing and therefore cannot affect the material response. Next we will employ the micropolar plasticity presented above to predict the experimental results displayed in Figs. 5.1 and 5.2.

5.5 Predicted responses for torsional loading of circular cylinders

Torsional loading of thin wires is modeled by using circular cylinders under monotonous torsional loading with fixed length. The finite element mesh employed is similar to the mesh used in [70] and consists of 60 eight-node solid elements. The two ends of the cylinders are subject to displacement boundary conditions of torsional type, with the microrotation being equal to the rotation resulting from the imposed deformation field at the ends. The remaining surfaces are supposed to be free of traction and couple traction loading. Geometrically similar circular cylinders are considered, with diameters corresponding to those in Figs. 5.1 and 5.2. The similarity of the cylinders allows the same finite element mesh to be utilized in all cases. (For more details see Grammenoudis and Tsakmakis [70].)

The following results are due to the isotropic hardening model accounting separately for strain and rotation gradient effects. Since uniaxial tension is a homogenous process, no rotation gradients are involved and the material parameters governing the response of the isotropic hardening variable R_1 can be determined from the experimental data in Figure 5.2 by using standard algorithms. In particular, the values β_1^{is} and γ_1^{is} have been established, to be 16 and 2,700 MPa, respectively, while we have assumed $\alpha_1 = 1$, $\alpha_2 = 0.5$, and $R_{10} = R_{20} = 0$ MPa (see also Grammenoudis and Tsakmakis [70]).

It was argued in Grammenoudis and Tsakmakis [70] that it is reasonable to expect that the size effects predicted by the constitutive model will be governed essentially by the yield function and the hardening rules, the effect of the elasticity law being negligible. Of course, imposed boundary conditions for micropolar rotations may also affect size effects, but such investigations are beyond the scope of the present paper. Consequently, we will concentrate ourself to the yield function and the isotropic hardening rule. However, the precise determination of material parameters α_3 , α_4 , β_2^{is} and γ_2^{is} is a difficult task and requires a lot of finite element calculations with long processing unit (CPU) times. Therefore, we content ourselves with only a study of the influence of these parameters on predicting size effects. The remaining material parameters, as well as the elasticity laws, are chosen as in Grammenoudis and Tsakmakis [70].

Figure 5.3 illustrates the predicted responses for the smallest (diameter $12\mu m$) and the largest specimen (diameter $170\mu m$). Evidently, it can be recognized that the constitutive theory is principally able to predict size effects. In Grammenoudis and Tsakmakis [70] it was concluded that, for the chosen material parameters, the kinematic hardening model is more suitable for describing the experimental results than the assumed isotropic hardening model capturing isotropic hardening effects in a unified manner. So, the overestimation of the experimental results was regarded as a characteristic feature of the assumed constitutive theory for isotropic hardening. From Fig. 5.3 one can conclude that the micropolar plasticity model equipped with isotropic hardening, accounting separately for strain and rotation gradient effects, is now able, in principle, to predict appropriately the experimental results reported in Fig. 5.1. This is in good agreement with classical models where the mechanical response due to monotonous loading may be described on a similar way by both the model of isotropic and the model of kinematical hardening. Also, Figs. 5.4–5.7 suggest that the parameters γ_2^{is} and β_2^{is} in Eqs. (5.25) and (5.38) affect, as one may expect, the response in the same way as do the classical parameters γ_1^{is} and β_1^{is} in the law (5.24) and (5.37). The results in Figs. 5.4–5.7 are for parameter values $\beta_2^{is} \in \{8, 12, 20, 100, 200\}$ and $\gamma_2^{is} \in \{900, 1, 800, 2, 700, 3, 500\}$ MPa as well as the smallest and the largest specimens. As the numerical simulations require large CPU times, only small amounts of shear strain are considered. Clearly, the parameters α_3 and α_4 in the yield function (5.11) affect the predicted size effects too. Indeed, as shown in Figs. 5.8 and 5.9 for the special case $\alpha_3 = \alpha_4$, we obtain smaller values for the normalized torque for larger the adopted values of α_3 .

However, some unexpected behaviour may arise, when predicted responses for all five specimens (diameters $2a = 12, 15, 20, 30,$ and $170\mu m$) are illustrated in the same diagram as shown in Fig. 5.10. It may be seen that the distance between the predicted responses for the larger specimens is smaller than the corresponding experimental data in Fig. 5.1. Moreover, the graph of the specimen with diameter $30\mu m$ covers a part of the graph of the specimen with diameter $170\mu m$. This latter effect is also displayed for the two largest specimens in Fig. 5.11, and was also observed in Grammenoudis and Tsakmakis [70] for the case of combined isotropic and kinematic hardening. Further calculations with finer meshes, not reported here, suggest that these results are independent on the chosen mesh. Also, all numerical operators employed, including the operator-split part for the local time integrations, are robust and stable, ensuring essentially quadratic convergence.

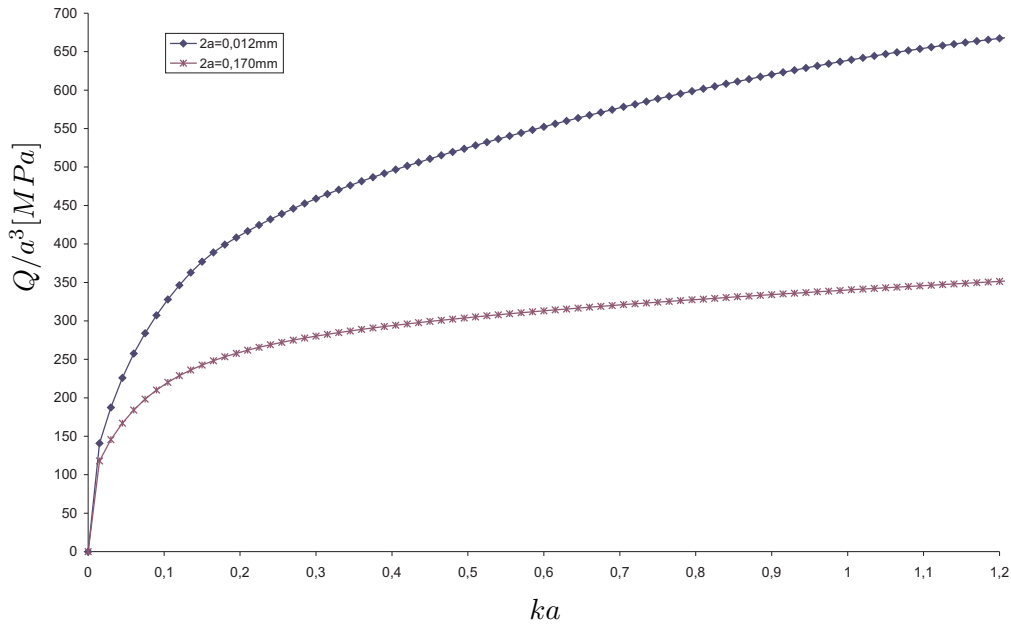

Figure 5.3: Predicted torsional responses for the smallest (diameter: $12\mu m$) and the largest specimen (diameter: $170\mu m$) for the set of material parameters $\beta_2^{is} = 200$, $\gamma_2^{is} = 2,700$ MPa and $\alpha_3 = \alpha_4 = 10,000mm^{-2}$.

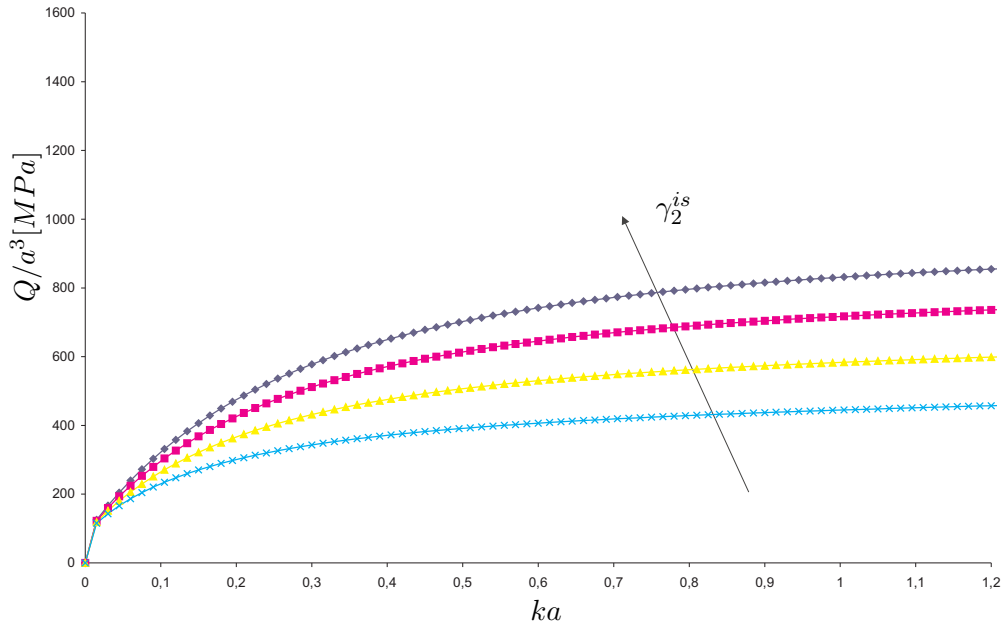

Figure 5.4: Predicted torsional responses for the largest specimen (diameter: $170\mu m$) and varying values of the parameter γ_2^{is} . The other plasticity parameters are fixed at $\beta_2^{is} = 16$ and $\alpha_3 = \alpha_4 = 10,000mm^{-2}$.

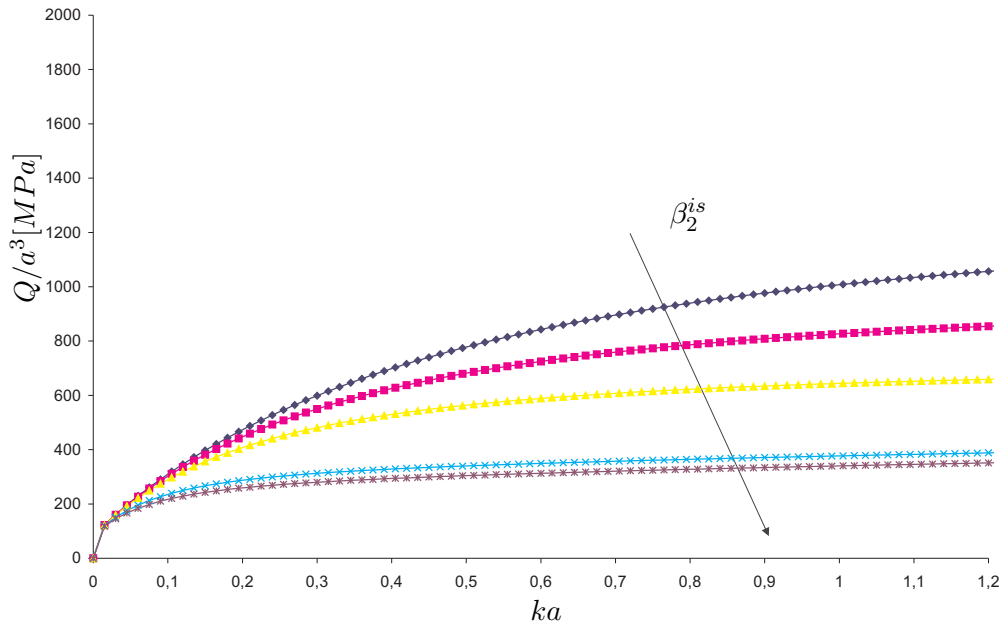

Figure 5.5: Predicted torsional responses for the largest specimen (diameter: $170\mu m$) and varying values of the parameter β_2^{is} . The other plasticity parameters are fixed at $\gamma_2^{is} = 2,700$ MPa and $\alpha_3 = \alpha_4 = 10,000mm^{-2}$.

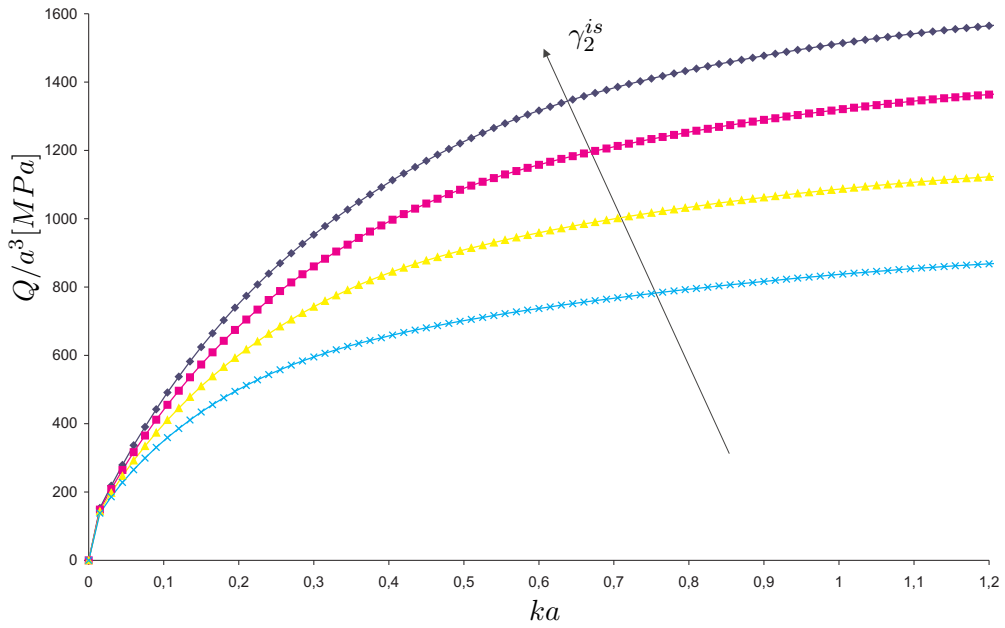

Figure 5.6: Predicted torsional responses for the smallest specimen (diameter: $12\mu m$) and varying values of the parameter γ_2^{is} . The other plasticity parameters are fixed at $\beta_2^{is} = 16$ and $\alpha_3 = \alpha_4 = 10,000mm^{-2}$.

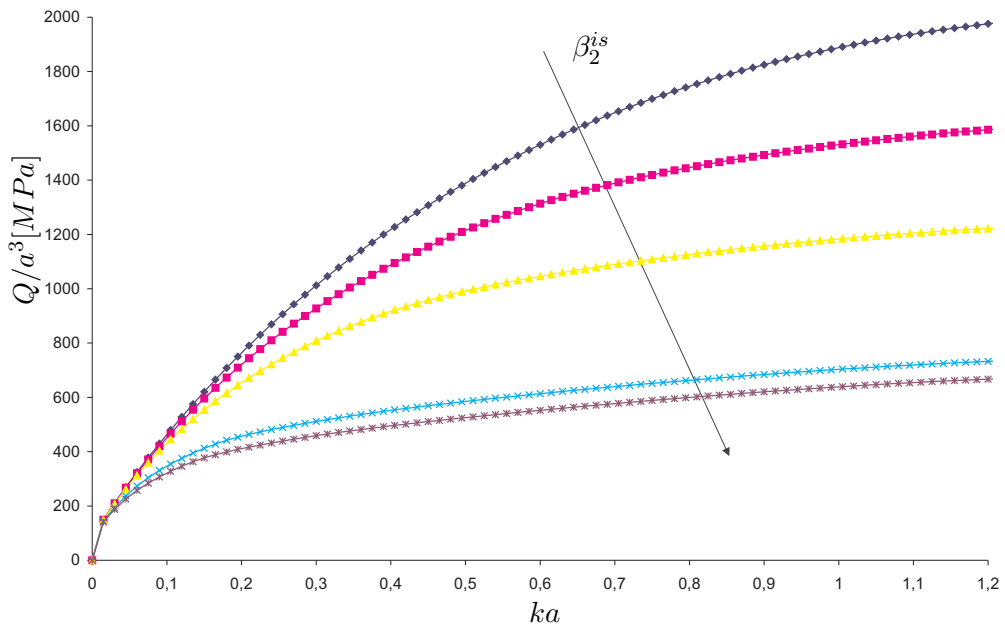

Figure 5.7: Predicted torsional responses for the smallest specimen (diameter: $12\mu m$) and varying values of the parameter β_2^{is} . The other plasticity parameters are fixed at $\gamma_2^{is} = 2,700$ MPa and $\alpha_3 = \alpha_4 = 10,000mm^{-2}$.

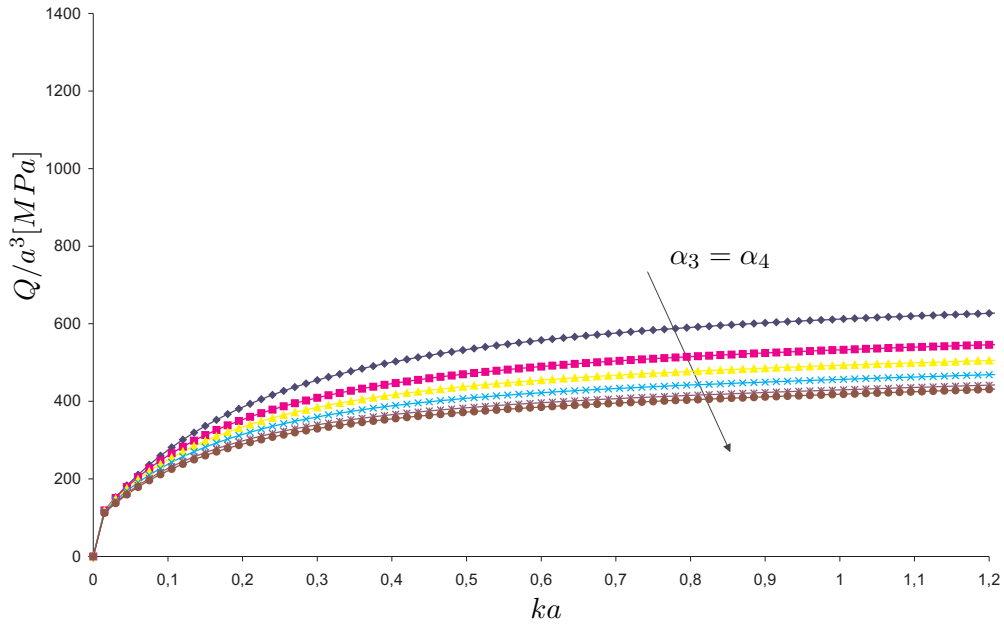

Figure 5.8: Predicted torsional responses for the largest specimen (diameter: $170\mu m$) and varying values of the parameters $\alpha_3 = \alpha_4$. The other plasticity parameters are fixed at $\beta_2^{is} = 20$ and $\gamma_2^{is} = 2,700$ MPa.

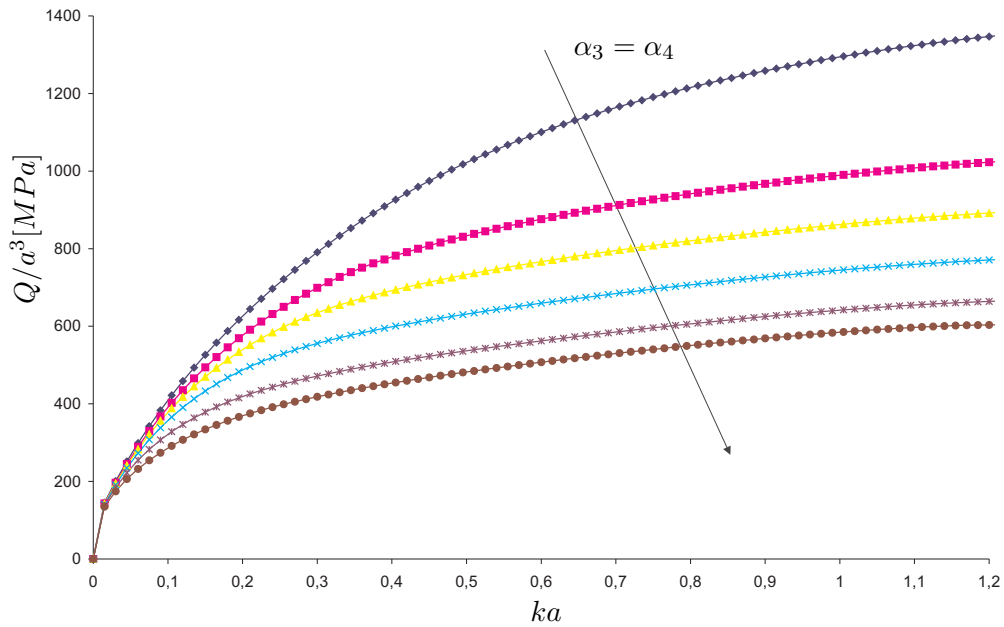

Figure 5.9: Predicted torsional responses for the smallest specimen (diameter: $12\mu m$) and varying values of the parameters $\alpha_3 = \alpha_4$. The other plasticity parameters are fixed at $\beta_2^{is} = 20$ and $\gamma_2^{is} = 2,700$ MPa.

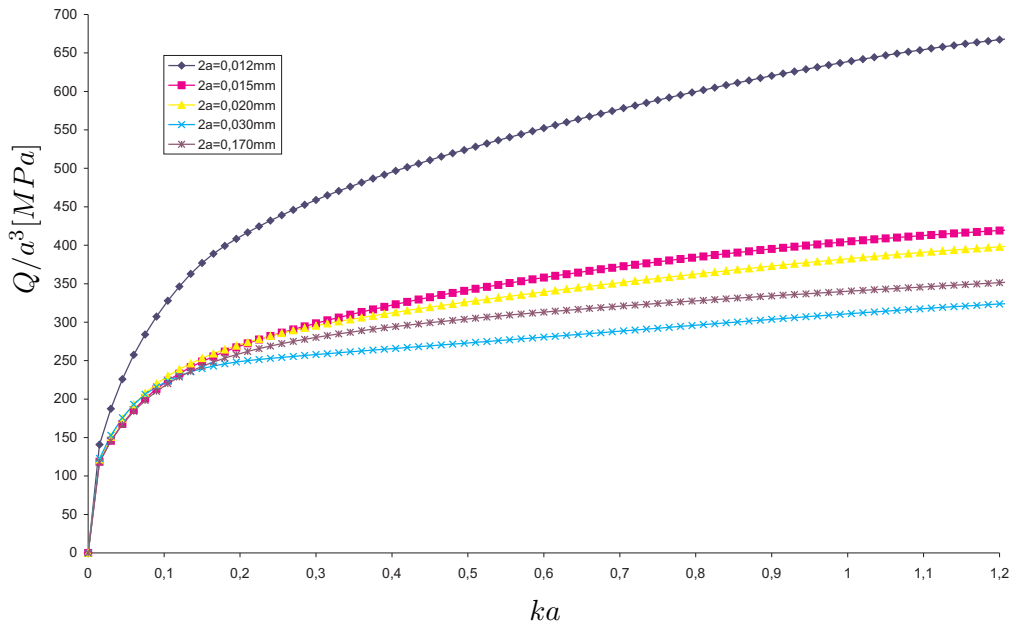

Figure 5.10: Predicted torsional responses for all five specimens (diameters $2a = 12, 15, 20, 30,$ and $170\mu m$) for the set of material parameters $\beta_2^{is} = 200, \gamma_2^{is} = 2, 700MPa$ and $\alpha_3 = \alpha_4 = 10, 000mm^{-2}$.

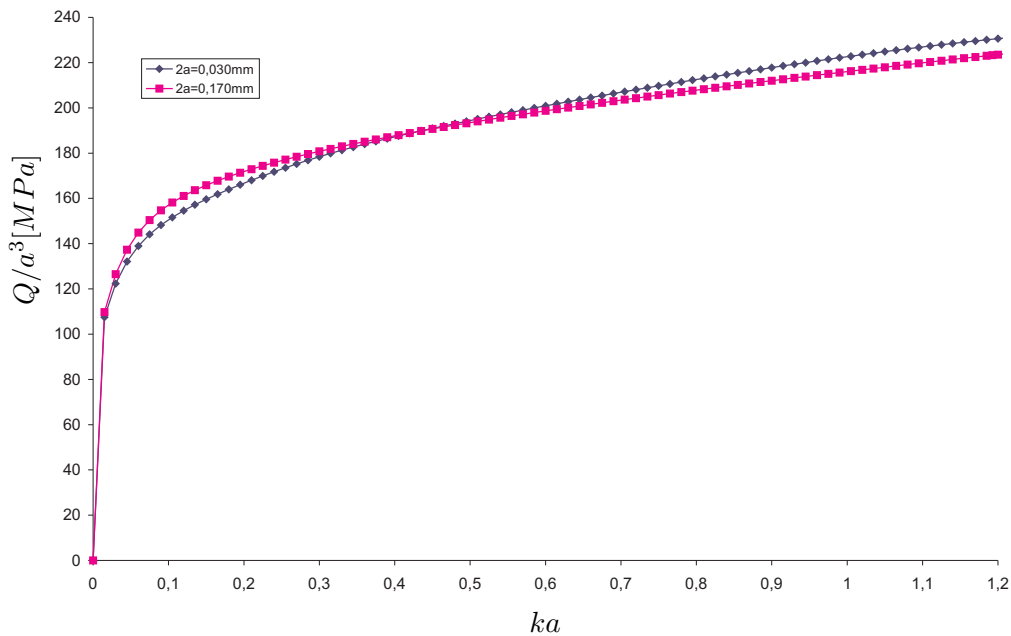

Figure 5.11: Predicted torsional responses for the specimen with diameter $30\mu m$ and the the largest specimen (diameter: $170\mu m$) for the set of material parameters $\beta_2^{is} = 200, \gamma_2^{is} = 1, 800MPa$ and $\alpha_1 = \alpha_2 = 0.75, \alpha_3 = \alpha_4 = 15, 000mm^{-2}$.

5.6 Concluding remarks

Thermodynamically consistent isotropic hardening models, which account separately for strain and rotation gradients in micropolar plasticity, have been established. Generally, the models are able to predict size effects in material behaviour more realistic than isotropic hardening laws capturing the influence of strains and rotation gradients in a unified manner. However, with increasing dimensions of specimens, some irregularities become observable in the predicted responses. It is claimed that this does not arise from the numerical approach applied. It may be that the reason lies in the chosen values of the material parameters, e.g., those present in the yield function. At time it is not clear if this reflects some unfortunate choice of material parameters or is the effect of the adopted constitutive theory and, in particular, the effect of the variables chosen to formulate the theory or even the chosen yield function. Such questions can be answered adequately after developing more efficient finite element schema, which require shorter calculation times than the schema used herein. Also, from the results in Figs. 5.4–5.7, one could expect that for some sets of material parameters, e.g., with large values of β_2^{is} , or for small amount of isotropic hardening R_2 , the proposed model will be able to predict adequately the observed experimental data for torsional loading. However, to answer this question precisely, one has to calculate the material parameters by using some professional identification algorithms. This will be the object of future work.

Finally, it has to be mentioned that there are further gradient models, such as those proposed by Aifantis [4], which allow modeling of size effects for torsional loading. However, the aim of the present paper is not to compare different gradient models with each other by discussing predicted responses, but rather to investigate the capabilities of the micropolar models.

6 Continuum damage models based on energy equivalence. Part I: Isotropic material response

P. Grammenoudis, D. Reckwerth, Ch. Tsakmakis

**International Journal of Damage Mechanics, 18
(2009), 31-63**

Continuum damage models based on energy equivalence. Part I: Isotropic material response

P. Grammenoudis^{*}, D. Reckwerth[°], Ch. Tsakmakis^{*}

**^{*}Darmstadt University of Technology, Institute of Continuum Mechanics,
Hochschulstraße 1, 64289 Darmstadt, Germany**

[°]Continental Teves AG & Co. oHG, Guerickestr. 7, 60488 Frankfurt am Main, Germany

Abstract

An energy equivalence method for modeling damage effects in material response is proposed. In the present article, the main issues of the method are discussed for the less complicated case of isotropic constitutive functions. Otherwise, the material response addressed is supposed to be (rate-independent) elasto-plastic exhibiting isotropic and kinematic hardening. In order to make clear the difference to other continuum damage models, it suffices to deal here with isotropic damage expressed in terms of a scalar state variable. Our approach is based on the concept of effective stress and effective strain combined with a principle of energy equivalence as explained in the article. As a result, both the yield function and the evolution equations governing the hardening response of the damaged material are obtained from a given undamaged model material. Characteristic properties of the damage theory proposed are illustrated by comparing predicted responses with those according to damage models based on the principle of strain equivalence.

6.1 Introduction

Continuum damage mechanics relies upon the works of Kachanov [92] and Robotnov [136], who considered creep rupture of metals under uniaxial loading. These works have been later extended in the framework of irreversible thermodynamics in order to describe general three-dimensional loading processes (see e.g. the literature cited in Skrzypek [146] and Chaboche [21]). There are three concepts for modelling damage effects within the continuum damage approach. The first one is the concept of effective stress combined with the strain equivalence hypothesis, which is attributed to Lemaitre and Chaboche (see e.g. [102]-[17]). The second one is the concept of effective strain combined with the stress equivalence hypothesis which has been introduced by Simo and Ju [143, 144]. The last concept, first introduced by Cordebois and Sidoroff [29], makes use of the notions of effective strain and effective stress and requires the principle of energy equivalence.

Generally, continuum damage models use the assumption that the unknown response functions for the real damaged material may be established from that ones for an undamaged fictitious material. The response functions for the latter are expressed in terms of effective stress and effective strain variables and are supposed to be known. Cordebois and Sidoroff [29] discussed the energy equivalence principle

for the case of pure elastic mechanical behavior. Interesting extensions to elastic-plastic materials were then proposed by Chow and Lu [24, 111] as well as Forster et al. [57]. Only isotropic hardening is considered in Chow and Lu [24] and an equivalence for the incremental plastic work is postulated. According to the assumptions made, the yield function for the real material is known and the effective accumulated plastic strain is gained by the principle. The latter is used to formulate the isotropic hardening rule for the real material. Both, isotropic and kinematic hardening are assumed to be present in the theory of Forster et al. [57]. Equivalence is defined for the free energy functions responsible for elasticity and for the energy stored in the material due to hardening, as well as for the dissipation potentials. The yield function for the real material is identical to that one for the undamaged material but expressed in terms of effective stresses.

An energy equivalence principle for modelling damage effects in material response is proposed in our papers. In Part I, we are concerned with (rate-independent) elasto-plasticity coupled with damage. In opposite to other continuum damage theories, we do generally not assume the yield function for the real material to be known or to be established from that one for the undamaged material by expressing the latter in terms of effective stresses only. Essential features of our approach can be summarized as follows. We postulate an equivalence for the material functions governing the plastic and the hardening powers. As a result, we obtain for the real material a family of yield functions, as well as the evolution equations for the hardening variables. In order to explain ideas as simple as possible, we restrict the presentation in Part I only to isotropic damage modelled by one scalar variable. Note that for isotropic damage, the strain equivalence principle has been turned out to be well established. Therefore, we shall discuss typical properties of our theory by comparing results with those derived by a corresponding theory in the framework of strain equivalence. The results are obtained numerically by employing the finite element method. For the case of a notched specimen under tension only some quantitative differences between the predicted responses may become visible. Anisotropic damage will be discussed in Part II.

Closing this section, we remark that damage theories on the basis of energy equivalence have the advantage, apart from physical aspects, to deal directly with symmetric stiffness tensors in the free energy functions when anisotropy is involved. This will be denoted in Part II of our article. Also, essential results according to the theory proposed here have been developed previously in Reckwerth and Tsakmakis [137]. However, since there are some arguments that there are not formulated clearly, or even they are incorrect, the present article offers a rigorous motivation for our continuum damage models.

6.2 Preliminaries – elasto-plastic constitutive models

Throughout the article, the underlying deformations are assumed to be small. We denote by \mathbf{E} the linearized strain tensor, while the Cauchy stress tensor is denoted by \mathbf{T} . Only isothermal deformation processes with homogeneous temperature distribution will be considered, and the second law of thermodynamics is assumed in the form of the Clausius-Duhem inequality. Since the formulation is not affected by a space dependence, an explicit reference to space will be dropped. Commonly the same symbol is used to designate a function and the value of that function at a point. However, if we deal with different representations of the same function, then different symbols will often be used. We write $\dot{\varphi}(t)$ for the material time derivative of a function $\varphi(t)$, where t is the time. Moreover, second-order tensors are denoted by bold-face letters, whereas fourth-order tensors are represented by bold-face

calligraphic letters. For two second-order tensors \mathbf{A} and \mathbf{B} , we write $\text{tr}\mathbf{A}$ for the trace of \mathbf{A} , \mathbf{A}^T for the transpose of \mathbf{A} , $\mathbf{A} \cdot \mathbf{B} = \text{tr}(\mathbf{A}\mathbf{B}^T)$ for the inner product between \mathbf{A} and \mathbf{B} , $\|\mathbf{A}\| = \sqrt{\mathbf{A} \cdot \mathbf{A}}$ for the Euclidian norm of \mathbf{A} , as well as $\mathbf{A} \otimes \mathbf{B}$ for the tensor product between \mathbf{A} and \mathbf{B} . We will use the symbol $\mathbf{1}$ for the second-order identity tensor, so that $\mathbf{A}^D = \mathbf{A} - \frac{1}{3}(\text{tr}\mathbf{A})\mathbf{1}$ is the deviator of \mathbf{A} , while \mathcal{E} is the fourth-order identity tensor operating in the space of all symmetric second-order tensors.

The (undamaged) elasto-plastic materials with isotropic and kinematic hardening we deal with in the present article are characterized by the following equations:

$$\mathbf{E} = \mathbf{E}_e + \mathbf{E}_p \quad , \quad (6.1)$$

$$\tilde{\Psi}(\mathbf{E}_e, \mathbf{Y}, r) = \tilde{\Psi}_e(\mathbf{E}_e) + \tilde{\Psi}_p(\mathbf{Y}, r) \quad , \quad (6.2)$$

$$\tilde{\Psi}_e(\mathbf{E}_e) = \frac{1}{2\rho} \mathbf{E}_e \cdot \mathbf{C}[\mathbf{E}_e] \quad , \quad (6.3)$$

$$\mathbf{C} := 2\mu\mathcal{E} + \lambda\mathbf{1} \otimes \mathbf{1} \quad , \quad (6.4)$$

$$\tilde{\Psi}_p(\mathbf{Y}, r) = \tilde{\Psi}_p^{kin}(\mathbf{Y}) + \tilde{\Psi}_p^{is}(r) \quad , \quad (6.5)$$

$$\tilde{\Psi}_p^{kin}(\mathbf{Y}) = \frac{c}{2\rho} \mathbf{Y} \cdot \mathbf{Y} \quad , \quad (6.6)$$

$$\tilde{\Psi}_p^{is}(r) = \frac{\gamma}{2\rho} r^2 \quad , \quad (6.7)$$

$$\boldsymbol{\xi} := \rho \frac{\partial \tilde{\Psi}_p^{kin}}{\partial \mathbf{Y}} = c\mathbf{Y} \quad , \quad (6.8)$$

$$R := \rho \frac{\partial \tilde{\Psi}_p^{is}}{\partial r} = \gamma r \quad , \quad (6.9)$$

$$r(t=0) = 0 \quad , \quad R(t=0) = 0 \quad , \quad (6.10)$$

$$\tilde{F}(\mathbf{T}, \boldsymbol{\xi}, R) := \tilde{f}(\mathbf{T} - \boldsymbol{\xi}, R) - k_0 \quad , \quad (6.11)$$

$$\tilde{f}(\mathbf{T} - \boldsymbol{\xi}, R) := \sqrt{\frac{3}{2}(\mathbf{T} - \boldsymbol{\xi})^D \cdot (\mathbf{T} - \boldsymbol{\xi})^D - R} \quad , \quad (6.12)$$

$$\tilde{F} = 0 \quad \Leftrightarrow \quad \tilde{f} = k_0 \quad : \quad \text{yield condition} \quad , \quad (6.13)$$

$$\text{plastic loading} \quad \Leftrightarrow \quad \tilde{F} = 0 \quad \& \quad \left(\frac{d}{dt} \tilde{F} \right)_{\mathbf{E}_p = \text{const}} > 0 \quad , \quad (6.14)$$

Flow rule:

$$\dot{\mathbf{E}}_p = \begin{cases} \tilde{\mathbf{f}}_p(\dot{s}, \mathbf{T}, \boldsymbol{\xi}, R) = \frac{\dot{s}}{\zeta} \frac{\partial \tilde{F}}{\partial \mathbf{T}} = \frac{\dot{s}}{\zeta} \frac{\partial \tilde{f}}{\partial (\mathbf{T} - \boldsymbol{\xi})} = \frac{3\dot{s}}{2\zeta} \frac{(\mathbf{T} - \boldsymbol{\xi})^D}{R + k_0} & \text{for plastic loading} \quad , \\ \mathbf{0} & \text{otherwise} \quad , \end{cases} \quad (6.15)$$

$$\dot{s} = \sqrt{\frac{2}{3} \dot{\mathbf{E}}_p \cdot \dot{\mathbf{E}}_p} \quad , \quad (6.16)$$

$$\zeta = \tilde{f}_\zeta(\mathbf{T} - \boldsymbol{\xi}, R) := \sqrt{\frac{2}{3} \frac{\partial \tilde{f}}{\partial (\mathbf{T} - \boldsymbol{\xi})} \cdot \frac{\partial \tilde{f}}{\partial (\mathbf{T} - \boldsymbol{\xi})}} = 1 \quad . \quad (6.17)$$

Clausius-Duhem inequality:

$$\mathbf{T} \cdot \dot{\mathbf{E}} - \rho \frac{d}{dt} \tilde{\Psi} = \mathbf{T} \cdot \dot{\mathbf{E}}_e + \mathbf{T} \cdot \dot{\mathbf{E}}_p - \rho \frac{d}{dt} \tilde{\Psi}_e - \rho \frac{d}{dt} \tilde{\Psi}_p \geq 0 \quad , \quad (6.18)$$

$$\mathbf{T} = \rho \frac{\partial \tilde{\Psi}_e}{\partial \mathbf{E}_e} = \mathbf{C}[\mathbf{E}_e] \quad : \quad \text{elasticity law} \quad . \quad (6.19)$$

Dissipation inequality:

$$\tilde{\mathcal{D}} := \mathbf{T} \cdot \dot{\mathbf{E}}_p - \varrho \frac{d}{dt} \tilde{\Psi}_p = \mathbf{T} \cdot \dot{\mathbf{E}}_p - \boldsymbol{\xi} \cdot \dot{\mathbf{Y}} - R\dot{r} = (\mathbf{T} - \boldsymbol{\xi}) \cdot \dot{\mathbf{E}}_p - R\dot{r} + \boldsymbol{\xi} \cdot (\dot{\mathbf{E}}_p - \dot{\mathbf{Y}}) \geq 0 \quad . \quad (6.20)$$

Kinematic hardening rule:

$$\dot{\mathbf{Y}} = \tilde{\mathbf{f}}_{\mathbf{Y}}(\dot{s}, \mathbf{T}, \boldsymbol{\xi}, R) = \dot{\mathbf{E}}_p - b \frac{\dot{s}}{\zeta} \boldsymbol{\xi} \quad . \quad (6.21)$$

Isotropic hardening rule:

$$\dot{r} = \tilde{f}_r(\dot{s}, \mathbf{T}, \boldsymbol{\xi}, R) = (1 - \beta R) \frac{\dot{s}}{\zeta} \quad . \quad (6.22)$$

Equation (6.1) is the decomposition of the strain tensor \mathbf{E} into elastic and plastic parts, $\tilde{\Psi}$ is the specific free energy function, ϱ is the mass density and μ, λ are the elasticity parameters. Isotropic and kinematic hardening are described by the state variables r and \mathbf{Y} , which represent a scalar strain ($r \geq 0$) and a second order strain tensor, respectively. From (6.8) and (6.9), we recognize that $\boldsymbol{\xi}$ and R are thermodynamically conjugated stresses to \mathbf{Y} and r , respectively. Often, $\boldsymbol{\xi}$ is called the back stress tensor. In Equations (6.6)–(6.11), γ, c, k_0 are material parameters. Equations (6.11)–(6.13) define the yield condition, with $k := k_0 + R$ and k_0 denoting the yield stress and the initial yield stress respectively. It is worth noticing that the initial value of isotropic hardening is assumed vanishing, $R(t = 0) = 0$. Nonvanishing initial values are important when modeling the energy stored in some metallic materials due to rearrangements of dislocations during plastic flow (cf. also Chaboche [19, 20]), but this problem is not addressed in our papers. Stresses $(\mathbf{T} - \boldsymbol{\xi}, \boldsymbol{\xi}, R)$ which do not contradict Equation (6.13) are called admissible plastic states. Plastic strain \mathbf{E}_p is governed by the flow rule, which has the form of an associated normality rule. For the chosen yield function the scalar ζ is constant equal to 1, but in other examples it will be function of state variables. In the case of rate-independent plasticity, we deal with in this article, the scalar multiplier \dot{s} has to be determined from the so-called consistency condition $\frac{d}{dt} \tilde{F} = 0$. Plastic flow is involved if the loading criteria (6.14) are satisfied. Using standard arguments, one may prove that the elasticity law (6.19) and the dissipation inequality (6.20) are sufficient conditions for the validity of the Clausius-Duhem inequality (6.18). Finally, (6.21) and (6.22) are evolution equations governing the response of the kinematic and isotropic hardening, respectively, with β, b being non-negative material parameters. To see that (6.21) and (6.22) do not contradict the dissipation inequality, we insert in (6.20) the flow rule (6.15) and the material time derivatives of (6.6) and (6.7), to obtain

$$\frac{\dot{s}}{\zeta} k_0 + R \left(\frac{\dot{s}}{\zeta} - \dot{r} \right) + \boldsymbol{\xi} \cdot (\dot{\mathbf{E}}_p - \dot{\mathbf{Y}}) \geq 0 \quad . \quad (6.23)$$

Since $\frac{\dot{s}}{\zeta} \geq 0$, we have $\frac{\dot{s}}{\zeta} k_0 \geq 0$. We recall that $r \geq 0$ has to hold, which implies $R \geq 0$, in view of (6.9). Therefore, the relations

$$R \left(\frac{\dot{s}}{\zeta} - \dot{r} \right) \geq 0 \quad , \quad (6.24)$$

$$\boldsymbol{\xi} \cdot (\dot{\mathbf{E}}_p - \dot{\mathbf{Y}}) \geq 0 \quad , \quad (6.25)$$

are sufficient conditions for (6.23) to hold. On the other hand, these inequalities are always satisfied, provided

$$\dot{\mathbf{E}}_p - \dot{\mathbf{Y}} = b \frac{\dot{s}}{\zeta} \boldsymbol{\xi} \quad , \quad (6.26)$$

$$\frac{\dot{s}}{\zeta} - \dot{r} = \beta \frac{\dot{s}}{\zeta} R \quad , \quad (6.27)$$

latter being identical to (6.21) and (6.22), respectively. Note that the evolution Equation (6.21), together with homogeneous initial conditions, render \mathbf{Y} , and therefore $\boldsymbol{\xi}$ too, to be deviatoric.

Alternatively, and equivalently, one may introduce a so-called dissipation potential

$$\tilde{\varphi}(\mathbf{T} - \boldsymbol{\xi}, \boldsymbol{\xi}, R) = \sqrt{\frac{3}{2}(\mathbf{T} - \boldsymbol{\xi})^D \cdot (\mathbf{T} - \boldsymbol{\xi})^D - R + \frac{\beta}{2}R^2 + \frac{b}{2}\boldsymbol{\xi} \cdot \boldsymbol{\xi}} \quad , \quad (6.28)$$

where $\tilde{\varphi}(\mathbf{T} - \boldsymbol{\xi}, \boldsymbol{\xi}, R)$ is a continuously differentiable convex scalar valued function. The surface $\tilde{\varphi}(\mathbf{T} - \boldsymbol{\xi}, \boldsymbol{\xi}, R) = \text{const}$ encloses a range of admissible plastic states $(\mathbf{T} - \boldsymbol{\xi}, \boldsymbol{\xi}, R)$, including the origin $(\mathbf{0}, \mathbf{0}, 0)$. Thus, the dissipation inequality (6.20) is automatically satisfied, provided the normality conditions

$$\dot{\mathbf{E}}_p = \frac{\dot{s}}{\zeta} \frac{\partial \tilde{\varphi}(\mathbf{T} - \boldsymbol{\xi}, \boldsymbol{\xi}, R)}{\partial (\mathbf{T} - \boldsymbol{\xi})} \quad , \quad (6.29)$$

$$\dot{\mathbf{E}}_p - \dot{\mathbf{Y}} = \frac{\dot{s}}{\zeta} \frac{\partial \tilde{\varphi}(\mathbf{T} - \boldsymbol{\xi}, \boldsymbol{\xi}, R)}{\partial \boldsymbol{\xi}} = b \frac{\dot{s}}{\zeta} \boldsymbol{\xi} \quad \Leftrightarrow \quad \dot{\mathbf{Y}} = \dot{\mathbf{E}}_p - b \frac{\dot{s}}{\zeta} \boldsymbol{\xi} \quad , \quad (6.30)$$

$$\dot{r} = -\frac{\dot{s}}{\zeta} \frac{\partial \tilde{\varphi}(\mathbf{T} - \boldsymbol{\xi}, \boldsymbol{\xi}, R)}{\partial R} = (1 - \beta R) \frac{\dot{s}}{\zeta} \quad , \quad (6.31)$$

hold. Actually, apart from formal differences, this is the approach advocated by Lemaitre and Chaboche [107].

Before going any further, it should be mentioned, that the plasticity model defined by (6.1)–(6.22) has been discussed intensively by Chaboche [19, 20] and is often attributed to him. Also, the evolution Equation (6.21) is equivalent to the so-called Armstrong-Frederick hardening rule. Finally, it is instructive to thought of the plastic power $\mathbf{T} \cdot \dot{\mathbf{E}}_p$, and the rates of energy stored in the material due to kinematic hardening $\boldsymbol{\xi} \cdot \dot{\mathbf{Y}}$, and due to isotropic hardening $R\dot{r}$, to be given by constitutive functions \tilde{w}_p , \tilde{w}_{kin} , and \tilde{w}_{is} of $(\dot{s}, \mathbf{T}, \boldsymbol{\xi}, R)$ respectively:

$$\tilde{w}_p(\dot{s}, \mathbf{T}, \boldsymbol{\xi}, R) := \mathbf{T} \cdot \tilde{\mathbf{f}}_p(\dot{s}, \mathbf{T}, \boldsymbol{\xi}, R) = \frac{\dot{s}}{\zeta} \mathbf{T} \cdot \frac{\partial \tilde{f}(\mathbf{T} - \boldsymbol{\xi}, R)}{\partial (\mathbf{T} - \boldsymbol{\xi})} \quad , \quad (6.32)$$

$$\tilde{w}_{kin}(\dot{s}, \mathbf{T}, \boldsymbol{\xi}, R) := \boldsymbol{\xi} \cdot \tilde{\mathbf{f}}_Y(\dot{s}, \mathbf{T}, \boldsymbol{\xi}, R) = \boldsymbol{\xi} \cdot \left(\tilde{\mathbf{f}}_p(\dot{s}, \mathbf{T}, \boldsymbol{\xi}, R) - b \frac{\dot{s}}{\zeta} \boldsymbol{\xi} \right) \quad , \quad (6.33)$$

$$\tilde{w}_{is}(\dot{s}, \mathbf{T}, \boldsymbol{\xi}, R) := R \tilde{f}_r(\dot{s}, \mathbf{T}, \boldsymbol{\xi}, R) = R(1 - \beta R) \frac{\dot{s}}{\zeta} \quad . \quad (6.34)$$

6.3 Basic assumptions

The continuum damage approach (see e.g. [19, 21]) makes the assumption that the set of state variables occurring in Section 6.2 is amplified by damage variables. For the aim of the present article, it suffices to confine on isotropic damage captured by a scalar valued variable $D \in [0, 1]$. The values $D = 0$ and $D = 1$ correspond to the undamaged state and the complete local rupture, respectively, while $D \in (0, 1)$ reflects a partially damaged state.

Common features in a large number of theories of continuum damage mechanics are the decomposition of strain

$$\mathbf{E} = \mathbf{E}_e + \mathbf{E}_p \quad , \quad (6.35)$$

as well as the existence of a specific free energy, which admits the representations

$$\Psi(t) = \bar{\Psi}(\mathbf{E}_e, \mathbf{Y}, r, D) = \Psi_e(t) + \Psi_p(t) \quad , \quad \Psi_p(t) = \Psi_p^{kin}(t) + \Psi_p^{is}(t) \quad , \quad (6.36)$$

$$\Psi_e(t) = \bar{\Psi}_e(\mathbf{E}_e, D) \quad , \quad \Psi_p^{kin}(t) = \bar{\Psi}_p^{kin}(\mathbf{Y}, D) \quad , \quad \Psi_p^{is}(t) = \bar{\Psi}_p^{is}(r, D) \quad . \quad (6.37)$$

Sufficient conditions for the Clausius-Duhem inequality

$$\bar{\mathcal{D}} := \mathbf{T} \cdot \dot{\mathbf{E}} - \rho \dot{\Psi}_e - \rho \dot{\Psi}_p^{kin} - \rho \dot{\Psi}_p^{is} \geq 0 \quad (6.38)$$

to hold, are the elasticity law

$$\mathbf{T} = \rho \frac{\partial \bar{\Psi}_e}{\partial \mathbf{E}_e} \quad , \quad (6.39)$$

together with the dissipation inequality

$$\bar{\mathcal{D}}_d := \mathbf{T} \cdot \dot{\mathbf{E}}_p - \boldsymbol{\xi} \cdot \dot{\mathbf{Y}} - R\dot{r} - \rho \frac{\partial \bar{\Psi}}{\partial D} \dot{D} \geq 0 \quad , \quad (6.40)$$

where

$$\boldsymbol{\xi} := \rho \frac{\partial \bar{\Psi}_p^{kin}}{\partial \mathbf{Y}} \quad , \quad R := \rho \frac{\partial \bar{\Psi}_p^{is}}{\partial r} \quad . \quad (6.41)$$

Clearly,

$$\bar{\mathcal{D}}_{dp} := \mathbf{T} \cdot \dot{\mathbf{E}}_p - \boldsymbol{\xi} \cdot \dot{\mathbf{Y}} - R\dot{r} = (\mathbf{T} - \boldsymbol{\xi}) \cdot \dot{\mathbf{E}}_p - R\dot{r} + \boldsymbol{\xi} \cdot (\dot{\mathbf{E}}_p - \dot{\mathbf{Y}}) \geq 0 \quad , \quad (6.42)$$

$$\bar{\mathcal{D}}_{dd} := -\rho \frac{\partial \bar{\Psi}}{\partial D} \dot{D} \geq 0 \quad (6.43)$$

are sufficient conditions for (6.40). Plastic flow is defined to occur whenever the condition for plastic loading

$$F(t) = \bar{F}(\mathbf{T}, \boldsymbol{\xi}, R, D) = \bar{f}(\mathbf{T} - \boldsymbol{\xi}, R, D) - k_0 \quad , \quad (6.44)$$

$$\text{plastic loading} \quad \Leftrightarrow \quad F = 0 \quad \& \quad (\dot{F})_{\mathbf{E}_p = \text{const}} > 0 \quad (6.45)$$

applies, where $\bar{F}(\mathbf{T}, \boldsymbol{\xi}, R, D)$ denotes the yield function. During plastic flow, evolution equations

$$\dot{\mathbf{E}}_p = \bar{\mathbf{f}}_p(\dot{s}, \mathbf{T}, \boldsymbol{\xi}, R, D) \quad , \quad (6.46)$$

$$\dot{\mathbf{Y}} = \bar{\mathbf{f}}_Y(\dot{s}, \mathbf{T}, \boldsymbol{\xi}, R, D) \quad , \quad (6.47)$$

$$\dot{r} = \bar{f}_r(\dot{s}, \mathbf{T}, \boldsymbol{\xi}, R, D) \quad (6.48)$$

are assumed to hold, where $\dot{s} = \sqrt{\frac{2}{3} \dot{\mathbf{E}}_p \cdot \dot{\mathbf{E}}_p}$, as in classical plasticity, has to be determined from the consistent condition $\dot{F} = 0$. Especially, we suppose the flow rule (6.46) to be represented by an associated normality rule,

$$\dot{\mathbf{E}}_p = \frac{\dot{s}}{\zeta} \frac{\partial \bar{F}}{\partial \mathbf{T}} = \frac{\dot{s}}{\zeta} \frac{\partial \bar{f}}{\partial (\mathbf{T} - \boldsymbol{\xi})} \quad , \quad (6.49)$$

with

$$\zeta = \bar{f}_\zeta(\mathbf{T} - \boldsymbol{\xi}, R, D) := \sqrt{\frac{2}{3} \frac{\partial \bar{f}}{\partial (\mathbf{T} - \boldsymbol{\xi})} \cdot \frac{\partial \bar{f}}{\partial (\mathbf{T} - \boldsymbol{\xi})}} \quad . \quad (6.50)$$

Similar to the theory without damage (see Section 6.2), (6.42) may be satisfied always by requiring normality conditions

$$\dot{\mathbf{E}}_p = \frac{\dot{s}}{\zeta} \frac{\partial \bar{\varphi}}{\partial (\mathbf{T} - \boldsymbol{\xi})} \quad , \quad \dot{\mathbf{E}}_p - \dot{\mathbf{Y}} = \frac{\dot{s}}{\zeta} \frac{\partial \bar{\varphi}}{\partial \boldsymbol{\xi}} \quad , \quad \dot{r} = -\frac{\dot{s}}{\zeta} \frac{\partial \bar{\varphi}}{\partial R} \quad , \quad (6.51)$$

where $\bar{\varphi}$ is a scalar valued function of $(\mathbf{T} - \boldsymbol{\xi}, \boldsymbol{\xi}, R, D)$,

$$\varphi(t) = \bar{\varphi}(\mathbf{T} - \boldsymbol{\xi}, \boldsymbol{\xi}, R, D) \quad , \quad (6.52)$$

representing an appropriate convex dissipation potential, with

$$\frac{\partial \bar{\varphi}(\mathbf{T} - \boldsymbol{\xi}, \boldsymbol{\xi}, R, D)}{\partial (\mathbf{T} - \boldsymbol{\xi})} = \frac{\partial \bar{F}(\mathbf{T}, \boldsymbol{\xi}, R, D)}{\partial \mathbf{T}} \quad . \quad (6.53)$$

The question now arises how to construct constitutive functions for the real (damaged) material from that ones in Section 6.2, which are supposed to govern the response of an undamaged fictitious material. For answering this question the strain equivalence and the energy equivalence principles are often used. Regarding isotropic damage, the theory based on the strain equivalence principle has been proved to be a very simple and efficient tool for modeling the constitutive behavior of ductile materials. Therefore, it is of interest here to compare responses predicted by this theory with those predicted by the constitutive theory established according to the energy equivalence principle, to be introduced later. To this end, we shall sketch briefly in the next section a model, which results from the strain equivalence principle and may be attributed to Chaboche [21]. In order to render the present work self-contained we shall derive this model from the constitutive relations given in Section 6.2.

6.4 Principle of strain equivalence

Continuums damage models which rest upon the strain equivalence principle, and are coupled with plastic material behavior, have been initiated and intensively investigated by Lemaitre and Chaboche [107]. Here, we shall apply a version of this principle to obtain from the model in Section 6.2 an elasto-plasticity theory coupled with damage effects. The essential features can be summarized as follows.

First we define effective stress variables $\mathbf{T}^{ef}, \boldsymbol{\xi}^{ef}, R^{ef}$ by

$$\mathbf{T}^{ef} := \frac{\mathbf{T}}{1-D} \quad , \quad \boldsymbol{\xi}^{ef} := \frac{\boldsymbol{\xi}}{1-D} \quad , \quad R^{ef} := \frac{R}{1-D} \quad . \quad (6.54)$$

Strain equivalence requires, on the one hand, the effective strain variables to be equal to the strain variables itself,

$$\mathbf{E}_e^{ef} \equiv \mathbf{E}_e \quad , \quad \mathbf{E}_p^{ef} \equiv \mathbf{E}_p \quad , \quad \mathbf{Y}^{ef} \equiv \mathbf{Y} \quad , \quad r^{ef} \equiv r \quad . \quad (6.55)$$

On the other hand, the constitutive equations for the real material arise from that of the fictitious (model) material, thereby replacing appropriately the strain and stress variables with the corresponding effective variables. In other words, from (6.19), (6.8)–(6.10), it follows that

$$\mathbf{T}^{ef} = \mathcal{C}[\mathbf{E}_e^{ef}] \equiv \mathcal{C}[\mathbf{E}_e] \quad , \quad (6.56)$$

$$\boldsymbol{\xi}^{ef} = c\mathbf{Y}^{ef} \equiv c\mathbf{Y} \quad , \quad (6.57)$$

$$R^{ef} = \gamma r^{ef} \equiv \gamma r \quad , \quad (6.58)$$

or

$$\mathbf{T} = (1 - D)\mathcal{C}[\mathbf{E}_e] \quad , \quad (6.59)$$

$$\boldsymbol{\xi} = (1 - D)c\mathbf{Y} \quad , \quad (6.60)$$

$$R = (1 - D)\gamma r \quad . \quad (6.61)$$

Equations (6.59)–(6.61) together with (6.39), (6.41) imply

$$\bar{\Psi}_e(\mathbf{E}_e, D) = \frac{1 - D}{2\rho} \mathbf{E}_e \cdot \mathcal{C}[\mathbf{E}_e] \quad , \quad (6.62)$$

$$\bar{\Psi}_p^{kin}(\mathbf{Y}, D) = \frac{1 - D}{2\rho} c\mathbf{Y} \cdot \mathbf{Y} \quad , \quad (6.63)$$

$$\bar{\Psi}_p^{is}(r, D) = \frac{1 - D}{2\rho} \gamma r^2 \quad . \quad (6.64)$$

Equations (6.11), (6.12) furnish for the yield function \bar{F} in (6.44)

$$\bar{f}(\mathbf{T} - \boldsymbol{\xi}, R, D) = \tilde{f}(\mathbf{T}^{ef} - \boldsymbol{\xi}^{ef}, R^{ef}) = \sqrt{\frac{3}{2}(\mathbf{T}^{ef} - \boldsymbol{\xi}^{ef})^D \cdot (\mathbf{T}^{ef} - \boldsymbol{\xi}^{ef})^D - R^{ef}} \quad , \quad (6.65)$$

so that

$$F(t) = \bar{F}(\mathbf{T}, \boldsymbol{\xi}, R, D) = \bar{f}(\mathbf{T} - \boldsymbol{\xi}, R, D) - k_0 = \sqrt{\frac{3}{2} \frac{(\mathbf{T} - \boldsymbol{\xi})^D \cdot (\mathbf{T} - \boldsymbol{\xi})^D}{1 - D} - \frac{R}{1 - D}} - k_0 \quad . \quad (6.66)$$

Furthermore, the dissipation function $\bar{\varphi}$ in (6.52) follows from $\tilde{\varphi}$ in (6.28), the latter being expressed in terms of effective variables:

$$\begin{aligned} \bar{\varphi}(\mathbf{T} - \boldsymbol{\xi}, \boldsymbol{\xi}, R, D) &= \tilde{\varphi}(\mathbf{T}^{ef} - \boldsymbol{\xi}^{ef}, \boldsymbol{\xi}^{ef}, R^{ef}) \\ &= \sqrt{\frac{3}{2}(\mathbf{T}^{ef} - \boldsymbol{\xi}^{ef})^D \cdot (\mathbf{T}^{ef} - \boldsymbol{\xi}^{ef})^D - R^{ef}} + \frac{\beta}{2}(R^{ef})^2 + \frac{b}{2}\boldsymbol{\xi}^{ef} \cdot \boldsymbol{\xi}^{ef} \\ &\equiv \sqrt{\frac{3}{2} \frac{(\mathbf{T} - \boldsymbol{\xi})^D \cdot (\mathbf{T} - \boldsymbol{\xi})^D}{1 - D} - \frac{R}{1 - D}} + \frac{1}{2}\beta \frac{R^2}{(1 - D)^2} + \frac{1}{2}b \frac{\boldsymbol{\xi} \cdot \boldsymbol{\xi}}{(1 - D)^2} \quad . \quad (6.67) \end{aligned}$$

It is not difficult to prove that for fixed D , \bar{f} in (6.66) and $\bar{\varphi}$ in (6.67) are convex functions of their arguments and that the surface $\bar{\varphi}(\mathbf{T} - \boldsymbol{\xi}, \boldsymbol{\xi}, R, D) = \text{const}$ encloses a range of admissible plastic states $(\mathbf{T} - \boldsymbol{\xi}, \boldsymbol{\xi}, R)$, including the origin $(\mathbf{0}, \mathbf{0}, 0)$. Thus, in view of (6.50)

$$\dot{\mathbf{E}}_p = \frac{3\dot{s}}{2\left(k_0 + \frac{R}{1-D}\right)} \frac{(\mathbf{T} - \boldsymbol{\xi})^D}{1 - D} \quad , \quad (6.68)$$

$$\dot{s} = \sqrt{\frac{3}{2}\dot{\mathbf{E}}_p \cdot \dot{\mathbf{E}}_p} \quad , \quad (6.69)$$

$$\zeta = \bar{f}_\zeta(\mathbf{T} - \boldsymbol{\xi}, R, D) := \sqrt{\frac{2}{3} \frac{\partial \bar{f}}{\partial (\mathbf{T} - \boldsymbol{\xi})} \cdot \frac{\partial \bar{f}}{\partial (\mathbf{T} - \boldsymbol{\xi})}} = \frac{1}{1 - D} \quad , \quad (6.70)$$

$$\dot{\mathbf{Y}} = \dot{\mathbf{E}}_p - b\dot{s}\frac{\boldsymbol{\xi}}{1-D} = \dot{\mathbf{E}}_p - bc\dot{s}\mathbf{Y} \quad , \quad (6.71)$$

$$\dot{r} = \left(1 - \beta\frac{R}{1-D}\right)\dot{s} = (1 - \beta\gamma r)\dot{s} \quad . \quad (6.72)$$

It still remains to check inequality (6.43). Keeping in mind (6.62)–(6.64),

$$-\varrho\frac{\partial\bar{\Psi}}{\partial D} = \frac{1}{2}(\mathbf{E}_e \cdot \mathbf{C}[\mathbf{E}_e] + c\mathbf{Y} \cdot \mathbf{Y} + \gamma r^2) = \varrho\tilde{\Psi}(\mathbf{E}_e, \mathbf{Y}, r) \quad , \quad (6.73)$$

which is always non-negative. This means that (6.43) will be satisfied in every case, provided

$$\dot{D} \geq 0 \quad . \quad (6.74)$$

In other words, any evolution equation rendering D to be a monotonically increasing function of time, will be compatible with (6.43).

It is a straight forward matter to show that for uniaxial tensile loading conditions, this model furnish the relations

$$\varepsilon = \varepsilon_e + \varepsilon_p \quad , \quad (6.75)$$

$$\sigma = (1 - D)E\varepsilon_e \quad , \quad (6.76)$$

$$\sigma - \frac{3}{2}\xi = R + (1 - D)k_0 \quad , \quad (6.77)$$

$$\xi = (1 - D)cy \quad , \quad (6.78)$$

$$R = (1 - D)\gamma r \quad , \quad (6.79)$$

$$\dot{y} = (1 - bcy)\dot{\varepsilon}_p \quad , \quad (6.80)$$

$$\dot{r} = (1 - \beta\gamma r)\dot{\varepsilon}_p \quad . \quad (6.81)$$

Here $E = \frac{\mu(3\lambda+2\mu)}{\lambda+\mu}$ is the Young's modulus, while σ , ε , ε_e , ε_p , ξ , y are the uniaxial components of \mathbf{T} , \mathbf{E} , \mathbf{E}_e , \mathbf{E}_p , $\boldsymbol{\xi}$, \mathbf{Y} , respectively. In order to obtain an insight into essential features of the model, we accomplish (6.75)–(6.81) with the simple damage law

$$D = \left(\frac{\varepsilon_p}{\alpha}\right)^2 \quad , \quad (6.82)$$

as indicated by Chaboche [21]. Figure 6.1 shows the strain-stress response according to these equations, for the material parameters given in Table 6.1. The case of ideal plasticity ($R = y = 0$) is also represented, for which (6.75)–(6.81) yield

$$\varepsilon_e = \frac{k_0}{E} = \text{const} \quad (6.83)$$

during plastic flow. It is readily seen, that for plasticity with isotropic and kinematic hardening, the elastic strain during plastic flow becomes

$$\varepsilon_e = \frac{3cy}{2E} + \frac{\gamma(r+r_0)}{E} + \frac{k_0}{E} \quad . \quad (6.84)$$

We recognize from (6.80), (6.81) that r , y are monotonically increasing functions of ε_p . Consequently, ε_e is a monotonically increasing function of ε_p as well, independent of the material parameters involved

Tabelle 6.1: Material parameters used in (6.75)–(6.81) in order to produce the strain-stress response with isotropic and kinematic hardening illustrated in Fig 6.1.

E [MPa]	k_0 [MPa]	r_0	c [MPa]	γ [MPa]	b [MPa]	β [MPa]	α
200000	200	0	30000	30000	10	10	0,02

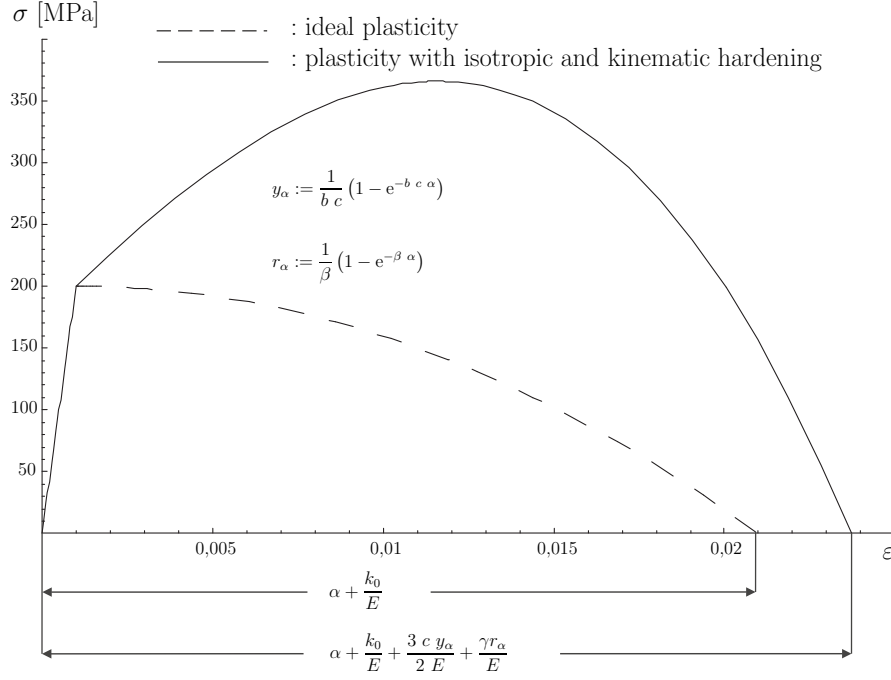

Figure 6.1: Strain-stress graphs for uniaxial tensile loading. The constitutive theory is based on the strain equivalence principle according to Chaboche [21].

in the hardening rules. As $\varepsilon_p \leq \alpha$, in view of (6.82), we infer from (6.84) that, during plastic flow, ε_e will remain bounded.

Before going any further, we remark that the model in this section has been discussed by Lämmer and Tsakmakis [110] with reference to further models derived from the strain equivalence principle. Also, it has been shown how the theory may be extended to finite deformations in a thermodynamically consistent way.

6.5 Proposed energy equivalence principle

Following Cordebois and Sidoroff [29], Chow and Lu [24] and Forster et al. [57], we introduce effective variables \mathbf{T}^{ef} , \mathbf{E}_e^{ef} , $\boldsymbol{\xi}^{ef}$, \mathbf{Y}^{ef} , R^{ef} , r^{ef} , \dot{s}^{ef} , and determine the constitutive equations for the real

material as follows. In order to deal with general defined effective variables, we set

$$\mathbf{T}^{ef} := \frac{\mathbf{T}}{m} \quad , \quad \mathbf{E}_e^{ef} := h\mathbf{E}_e \quad , \quad (6.85)$$

$$\boldsymbol{\xi}^{ef} := \frac{\boldsymbol{\xi}}{m} \quad , \quad \mathbf{Y}^{ef} := h\mathbf{Y} \quad , \quad (6.86)$$

$$R^{ef} := \frac{R}{m} \quad , \quad r^{ef} := hr \quad , \quad (6.87)$$

where m, h are functions of D ,

$$m = m(D) \quad , \quad h = h(D) \quad . \quad (6.88)$$

Whereas $m(D)$ is supposed to be given, $h(D)$ has to be determined from the assumed energy equivalence principle. In particular, we choose

$$m = (1 - D)^{\frac{q}{2}} \quad , \quad (6.89)$$

with q being a non-negative material parameter.

In all the aforementioned papers, the yield function for the real material is supposed to be known in terms of effective stresses, \dot{s}^{ef} , which can be determined from the adopted energy equivalence, or it is not necessary at all to know it explicitly. In contrast to such approaches, in our theory we assume \dot{s}^{ef} to be known and we shall determine the yield function for the real material from the energy equivalence principle to be defined below. To be more specific, we set

$$\frac{\dot{s}^{ef}}{\zeta^{ef}} := g \frac{\dot{s}}{\zeta} \quad , \quad (6.90)$$

with (cf. Equations (6.17) and (6.70))

$$\zeta^{ef} := \tilde{f}_\zeta(\mathbf{T}^{ef} - \boldsymbol{\xi}^{ef}, R^{ef}) \quad , \quad \zeta = \bar{f}_\zeta(\mathbf{T} - \boldsymbol{\xi}, R, D) \quad , \quad (6.91)$$

and g being given as a function of state variables. In this article, we make the ansatz

$$g = g(D) = (1 - D)^{\frac{q-2n}{2}} \quad , \quad (6.92)$$

where n denotes a material parameter.

Then, we get h and $\bar{\Psi}_e, \bar{\Psi}_p^{kin}, \bar{\Psi}_p^{is}$, by postulating

$$\bar{\Psi}_e(\mathbf{E}_e, D) = \tilde{\Psi}_e(\mathbf{E}_e^{ef}) = \frac{1}{2\rho} \mathbf{E}_e^{ef} \cdot \mathbf{C}[\mathbf{E}_e^{ef}] \quad , \quad (6.93)$$

$$\bar{\Psi}_p^{kin}(\mathbf{Y}, D) = \tilde{\Psi}_p^{kin}(\mathbf{Y}^{ef}) = \frac{c}{2\rho} \mathbf{Y}^{ef} \cdot \mathbf{Y}^{ef} \quad , \quad (6.94)$$

$$\bar{\Psi}_p^{is}(r, D) = \tilde{\Psi}_p^{is}(r^{ef}) = \frac{\gamma}{2\rho} (r^{ef})^2 \quad , \quad (6.95)$$

combined with the relations

$$\mathbf{T}^{ef} = \rho \frac{\partial \tilde{\Psi}_e(\mathbf{E}_e^{ef})}{\partial \mathbf{E}_e^{ef}} = \mathbf{C}[\mathbf{E}_e^{ef}] \quad , \quad (6.96)$$

$$\boldsymbol{\xi}^{ef} = \rho \frac{\partial \tilde{\Psi}_p^{kin}(\mathbf{Y}^{ef})}{\partial \mathbf{Y}^{ef}} = c\mathbf{Y}^{ef} \quad , \quad (6.97)$$

$$R^{ef} = \rho \frac{\partial \tilde{\Psi}_p^{is}(r^{ef})}{\partial r^{ef}} = \gamma r^{ef} \quad . \quad (6.98)$$

It is emphasized, that through Equations (6.93)–(6.95) we do not set the values of the free energies of the real material, subject to the real deformation process, at any time equal to the corresponding values of the free energy functions of the fictitious material, subject to some specific deformation processes. All what we do is that we determine the form of the functions $\tilde{\Psi}_e$, $\tilde{\Psi}_p^{kin}$, $\tilde{\Psi}_p^{is}$, from that one of the functions $\tilde{\Psi}_e$, $\tilde{\Psi}_p^{kin}$, $\tilde{\Psi}_p^{is}$, respectively, by way of Equations (6.93)–(6.95).

From Equations (6.93)–(6.98), as well as Equations (6.39) and (6.41), we conclude that, on the one hand

$$\frac{\partial \tilde{\Psi}_e}{\partial \mathbf{E}_e} = h \frac{\partial \tilde{\Psi}_e}{\partial \mathbf{E}_e^{ef}} \quad , \quad \frac{\partial \tilde{\Psi}_e}{\partial D} = \frac{\partial h}{\partial D} \frac{\partial \tilde{\Psi}_e}{\partial \mathbf{E}_e^{ef}} \cdot \mathbf{E}_e \quad , \quad (6.99)$$

$$\frac{\partial \tilde{\Psi}_p^{kin}}{\partial \mathbf{Y}} = h \frac{\partial \tilde{\Psi}_p^{kin}}{\partial \mathbf{Y}^{ef}} \quad , \quad \frac{\partial \tilde{\Psi}_p^{kin}}{\partial D} = \frac{\partial h}{\partial D} \frac{\partial \tilde{\Psi}_p^{kin}}{\partial \mathbf{Y}^{ef}} \cdot \mathbf{Y} \quad , \quad (6.100)$$

$$\frac{\partial \tilde{\Psi}_p^{is}}{\partial r} = h \frac{\partial \tilde{\Psi}_p^{is}}{\partial r^{ef}} \quad , \quad \frac{\partial \tilde{\Psi}_p^{is}}{\partial D} = \frac{\partial h}{\partial D} \frac{\partial \tilde{\Psi}_p^{is}}{\partial r^{ef}} r \quad , \quad (6.101)$$

and therefore

$$h(D) = m(D) = (1 - D)^{\frac{q}{2}} \quad . \quad (6.102)$$

On the other hand,

$$\tilde{\Psi}_e(\mathbf{E}_e, D) = \frac{(1 - D)^q}{2\rho} \mathbf{E}_e \cdot \mathbf{C}[\mathbf{E}_e] \quad , \quad (6.103)$$

$$\tilde{\Psi}_p^{kin}(\mathbf{Y}, D) = \frac{(1 - D)^q}{2\rho} c \mathbf{Y} \cdot \mathbf{Y} \quad , \quad (6.104)$$

$$\tilde{\Psi}_p^{is}(r, D) = \frac{(1 - D)^q}{2\rho} \gamma r^2 \quad (6.105)$$

and

$$\mathbf{T} = \rho \frac{\partial \tilde{\Psi}_e}{\partial \mathbf{E}_e} = (1 - D)^q \mathbf{C}[\mathbf{E}_e] \quad , \quad (6.106)$$

$$\boldsymbol{\xi} = \rho \frac{\partial \tilde{\Psi}_p^{kin}}{\partial \mathbf{Y}} = (1 - D)^q c \mathbf{Y} \quad , \quad (6.107)$$

$$R = \rho \frac{\partial \tilde{\Psi}_p^{is}}{\partial r} = (1 - D)^q \gamma r \quad . \quad (6.108)$$

At this stage, it is appropriate to discuss why s^{ef} in Equation (6.90) is defined unlike the effective strains in Equations (6.85)–(6.87). This may be justified as follows. With respect to metallic materials, energy can be stored in the material only by means of lattice distortion. For given loading conditions, damage will affect the internal distribution of the state variables and the local geometry of the material (e.g., by changing the face of microcracks, microvoids, etc.), but otherwise the way the damaged material will store energy will remain the same as for the undamaged material. This is reflected by Equations (6.93)–(6.95). On the other side, the physical mechanisms generating plastic flow (e.g., movement of dislocations) will be the same for both the real and the undamaged material. This is accounted

for by assuming the flow rule in Equation (6.49) to possess the same structure as in Equation (6.15). But one may expect that the presence of damage will disturb the local geometry of the material so that it will produce conditions e.g., for movement of dislocations, which are somewhat different from those of the undamaged material at the same material point. This is interpreted so that plastic flow for the real material will exhibit a different intensity from that one for the undamaged material, which is realized by using a definition in Equation (6.90) different from that ones in Equations (6.93)–(6.95).

Let the stress powers $\mathbf{T} \cdot \dot{\mathbf{E}}_p$, $\boldsymbol{\xi} \cdot \dot{\mathbf{Y}}$, $R\dot{r}$ be represented as functions of state variables:

$$\bar{w}_p(\dot{s}, \mathbf{T}, \boldsymbol{\xi}, R, D) := \mathbf{T} \cdot \bar{\mathbf{f}}_p(\dot{s}, \mathbf{T}, \boldsymbol{\xi}, R, D) = \frac{\dot{s}}{\zeta} \mathbf{T} \cdot \frac{\partial \bar{F}(\mathbf{T}, \boldsymbol{\xi}, R, D)}{\partial \mathbf{T}} \quad , \quad (6.109)$$

$$\bar{w}_{kin}(\dot{s}, \mathbf{T}, \boldsymbol{\xi}, R, D) := \boldsymbol{\xi} \cdot \bar{\mathbf{f}}_Y(\dot{s}, \mathbf{T}, \boldsymbol{\xi}, R, D) \quad , \quad (6.110)$$

$$\bar{w}_{is}(\dot{s}, \mathbf{T}, \boldsymbol{\xi}, R, D) := R \bar{f}_r(\dot{s}, \mathbf{T}, \boldsymbol{\xi}, R, D) \quad . \quad (6.111)$$

We accomplish our energy equivalence principle by assuming that the real material dissipates stress power in a manner similar to that of the undamaged material, the latter being expressed in terms of effective variables. That is, we postulate for the power functions the equivalence

$$\bar{w}_p(\dot{s}, \mathbf{T}, \boldsymbol{\xi}, R, D) = \tilde{w}_p(\dot{s}^{ef}, \mathbf{T}^{ef}, \boldsymbol{\xi}^{ef}, R^{ef}) \quad , \quad (6.112)$$

$$\bar{w}_{kin}(\dot{s}, \mathbf{T}, \boldsymbol{\xi}, R, D) = \tilde{w}_{kin}(\dot{s}^{ef}, \mathbf{T}^{ef}, \boldsymbol{\xi}^{ef}, R^{ef}) \quad , \quad (6.113)$$

$$\bar{w}_{is}(\dot{s}, \mathbf{T}, \boldsymbol{\xi}, R, D) = \tilde{w}_{is}(\dot{s}^{ef}, \mathbf{T}^{ef}, \boldsymbol{\xi}^{ef}, R^{ef}) \quad . \quad (6.114)$$

Again it has to be remarked, that we do not assume that besides the real material there exists a fictitious one, which produces e.g., plastic stress power equal to that one produced by the real material, at any time. But it is assumed that there exists a fictitious material, whose constitutive functions describing stress powers, \tilde{w}_p , \tilde{w}_{kin} , \tilde{w}_{is} , are related to the constitutive functions, \bar{w}_p , \bar{w}_{kin} , \bar{w}_{is} , describing corresponding stress powers for the real material, on the way stipulated by (6.112)–(6.114).

6.5.1 Yield function – flow rule

After incorporating (6.32), (6.109), and (6.44) into (6.112),

$$\frac{\dot{s}}{\zeta} \mathbf{T} \cdot \frac{\partial \bar{f}(\mathbf{T} - \boldsymbol{\xi}, R, D)}{\partial (\mathbf{T} - \boldsymbol{\xi})} = \frac{\dot{s}^{ef}}{\zeta^{ef}} \mathbf{T}^{ef} \cdot \frac{\partial \tilde{f}(\mathbf{T}^{ef} - \boldsymbol{\xi}^{ef}, R^{ef})}{\partial (\mathbf{T}^{ef} - \boldsymbol{\xi}^{ef})} \quad , \quad (6.115)$$

or, by virtue of (6.90) and (6.85),

$$\mathbf{T} \cdot \frac{\partial \bar{f}(\mathbf{T} - \boldsymbol{\xi}, R, D)}{\partial (\mathbf{T} - \boldsymbol{\xi})} = \frac{g}{m} \mathbf{T} \cdot \frac{\partial \tilde{f}(\mathbf{T}^{ef} - \boldsymbol{\xi}^{ef}, R^{ef})}{\partial (\mathbf{T}^{ef} - \boldsymbol{\xi}^{ef})} \quad , \quad (6.116)$$

which is satisfied if

$$\frac{\partial \bar{f}(\mathbf{T} - \boldsymbol{\xi}, R, D)}{\partial (\mathbf{T} - \boldsymbol{\xi})} = \frac{g}{m} \frac{\partial \tilde{f}(\mathbf{T}^{ef} - \boldsymbol{\xi}^{ef}, R^{ef})}{\partial (\mathbf{T}^{ef} - \boldsymbol{\xi}^{ef})} \quad . \quad (6.117)$$

A solution of this differential equation reads

$$\bar{f}(\mathbf{T} - \boldsymbol{\xi}, R, D) = g \tilde{f}(\mathbf{T}^{ef} - \boldsymbol{\xi}^{ef}, R^{ef}) = g \left\{ \sqrt{\frac{3}{2} \frac{(\mathbf{T} - \boldsymbol{\xi})^D}{m} \cdot \frac{(\mathbf{T} - \boldsymbol{\xi})^D}{m}} - \frac{R}{m} \right\} \quad . \quad (6.118)$$

The yield function in (6.44) obtains then the form

$$\begin{aligned}\bar{F}(\mathbf{T}, \boldsymbol{\xi}, R, D) &= \frac{g}{m} \left\{ \sqrt{\frac{3}{2}(\mathbf{T} - \boldsymbol{\xi})^D \cdot (\mathbf{T} - \boldsymbol{\xi})^D} - R \right\} - k_0 \\ &= (1 - D)^{-n} \left\{ \sqrt{\frac{3}{2}(\mathbf{T} - \boldsymbol{\xi})^D \cdot (\mathbf{T} - \boldsymbol{\xi})^D} - R \right\} - k_0 \quad ,\end{aligned}\quad (6.119)$$

the flow rule in (6.49) becomes

$$\dot{\mathbf{E}}_p = \sqrt{\frac{3}{2}} \dot{s} \frac{(\mathbf{T} - \boldsymbol{\xi})^D}{\|(\mathbf{T} - \boldsymbol{\xi})^D\|} \quad , \quad (6.120)$$

and ζ reads

$$\zeta = \frac{g}{m} = (1 - D)^{-n} \quad . \quad (6.121)$$

A family of yield functions \bar{F} , parametrized by n , has been introduced by Equation (6.119). This is an important result which makes transparent the differences to other approaches in the context of energy equivalence methods. A discussion of possible values for the parameter n is given in Section 6.6.

6.5.2 Hardening rules

We insert in (6.113) the relations (6.33) and (6.110), to get

$$\boldsymbol{\xi} \cdot \bar{\mathbf{f}}_{\mathbf{Y}}(\dot{s}, \mathbf{T}, \boldsymbol{\xi}, R, D) = \boldsymbol{\xi}^{ef} \cdot \tilde{\mathbf{f}}_{\mathbf{Y}}(\dot{s}^{ef}, \mathbf{T}^{ef}, \boldsymbol{\xi}^{ef}, R^{ef}) \quad . \quad (6.122)$$

This may be recast as

$$\begin{aligned}\boldsymbol{\xi} \cdot \bar{\mathbf{f}}_{\mathbf{Y}}(\dot{s}, \mathbf{T}, \boldsymbol{\xi}, R, D) &= \frac{\boldsymbol{\xi}}{m} \cdot \left\{ \tilde{\mathbf{f}}_{\mathbf{Y}}(\dot{s}^{ef}, \mathbf{T}^{ef}, \boldsymbol{\xi}^{ef}, R^{ef}) - b \frac{\dot{s}^{ef}}{\zeta^{ef}} \boldsymbol{\xi}^{ef} \right\} \\ &= \boldsymbol{\xi} \cdot \left\{ \frac{\dot{s}^{ef}}{m \zeta^{ef}} \frac{\partial \tilde{\mathbf{f}}(\mathbf{T}^{ef} - \boldsymbol{\xi}^{ef}, R^{ef})}{\partial (\mathbf{T}^{ef} - \boldsymbol{\xi}^{ef})} - b \frac{\dot{s}^{ef}}{m \zeta^{ef}} \boldsymbol{\xi}^{ef} \right\} \\ &= \boldsymbol{\xi} \cdot \left\{ \frac{\dot{s}}{\zeta} \frac{\partial \bar{\mathbf{f}}(\mathbf{T} - \boldsymbol{\xi}, R, D)}{\partial (\mathbf{T} - \boldsymbol{\xi})} - b \dot{s} \frac{\boldsymbol{\xi}}{m} \right\} \\ &= \boldsymbol{\xi} \cdot \left\{ \dot{\mathbf{E}}_p - b \dot{s} \frac{\boldsymbol{\xi}}{m} \right\} \quad ,\end{aligned}\quad (6.123)$$

which implies

$$\bar{\mathbf{f}}_{\mathbf{Y}}(\dot{s}, \mathbf{T}, \boldsymbol{\xi}, R, D) = \dot{\mathbf{E}}_p - b \dot{s} \frac{\boldsymbol{\xi}}{m} \quad , \quad (6.124)$$

and therefore

$$\dot{\mathbf{Y}} = \dot{\mathbf{E}}_p - b \dot{s} \frac{\boldsymbol{\xi}}{m} = \dot{\mathbf{E}}_p - b c m \dot{s} \mathbf{Y} \quad . \quad (6.125)$$

The corresponding equation for isotropic hardening may be gained from (6.114) on a similar way,

$$R \bar{f}_r(\dot{s}, \mathbf{T}, \boldsymbol{\xi}, R, D) = R^{ef} \tilde{f}_r(\dot{s}^{ef}, \mathbf{T}^{ef}, \boldsymbol{\xi}^{ef}, R^{ef}) \quad (6.126)$$

from which

$$\dot{r} = \left(1 - \beta \frac{R}{m} \right) \dot{s} = (1 - \beta \gamma m r) \dot{s} \quad . \quad (6.127)$$

6.5.3 Dissipation inequality – dissipation potential

First, we shall examine compatibility of the derived evolution equations with the dissipation inequality (6.42). For doing this, we need the expressions $(\mathbf{T} - \boldsymbol{\xi}) \cdot \dot{\mathbf{E}}_p$, $R\dot{r}$, $\boldsymbol{\xi} \cdot (\dot{\mathbf{E}}_p - \dot{\mathbf{Y}})$, for which, after some algebraic manipulations, we obtain

$$(\mathbf{T} - \boldsymbol{\xi}) \cdot \dot{\mathbf{E}}_p = \frac{m}{g} k_0 \dot{s} + R \dot{s} \quad , \quad (6.128)$$

$$R\dot{r} = R \dot{s} - \beta R \frac{R}{m} \dot{s} \quad , \quad (6.129)$$

$$\boldsymbol{\xi} \cdot (\dot{\mathbf{E}}_p - \dot{\mathbf{Y}}) = b \dot{s} \frac{\boldsymbol{\xi} \cdot \boldsymbol{\xi}}{m} \quad . \quad (6.130)$$

On substituting into (6.42),

$$\mathcal{D}_{dp} = \left\{ \frac{m}{g} k_0 + \beta \frac{R^2}{m} + b \frac{\boldsymbol{\xi} \cdot \boldsymbol{\xi}}{m} \right\} \dot{s} \quad , \quad (6.131)$$

which is always non-negative. Also to prove inequality (6.43), we calculate, from (6.103)–(6.105),

$$- \varrho \frac{\partial \bar{\Psi}}{\partial D} = \frac{q(1-D)^{q-1}}{2} \{ \mathbf{E}_e \cdot \mathcal{C}[\mathbf{E}_e] + c \mathbf{Y} \cdot \mathbf{Y} + \gamma r^2 \} = \frac{q(1-D)^{q-1}}{2} \tilde{\Psi}(\mathbf{E}_e, \mathbf{Y}, r) \geq 0 \quad . \quad (6.132)$$

Again, it is sufficient to require

$$\dot{D} \geq 0 \quad (6.133)$$

in order to ensure the validity of (6.43), and therefore the validity of the whole dissipation inequality (6.40).

It is not difficult to see that the flow rule (6.120), the kinematic hardening rule (6.125) and the isotropic hardening rule (6.127) can alternatively be derived from (6.52), with $\bar{\varphi}$ given by

$$\begin{aligned} \bar{\varphi}(\mathbf{T} - \boldsymbol{\xi}, \boldsymbol{\xi}, R, D) &:= g \left\{ \sqrt{\frac{3}{2} (\mathbf{T}^{ef} - \boldsymbol{\xi}^{ef})^D \cdot (\mathbf{T}^{ef} - \boldsymbol{\xi}^{ef})^D - R^{ef} + \frac{\beta}{2} (R^{ef})^2 + \frac{b}{2} \boldsymbol{\xi}^{ef} \cdot \boldsymbol{\xi}^{ef}} \right\} \\ &= \frac{g}{m} \left\{ \sqrt{\frac{3}{2} (\mathbf{T} - \boldsymbol{\xi})^D \cdot (\mathbf{T} - \boldsymbol{\xi})^D - R + \frac{\beta}{2m} R^2 + \frac{b}{2m} \boldsymbol{\xi} \cdot \boldsymbol{\xi}} \right\} \quad . \end{aligned} \quad (6.134)$$

As far as the dissipation function $\bar{\varphi}$ is concerned, a characteristic property of our model is the dependence of $\bar{\varphi}$ upon the scalar multiplier $g(D)$. If one chooses $2n = q = 1 (\Rightarrow g(D) = 1)$, then $\bar{\varphi}$ in (6.134) reduces essentially to the dissipation potential introduced by Forster et al. [57].

6.6 Discussion of the model

The resulting model from the proposed energy equivalence is now summarized:

$$\mathbf{E} = \mathbf{E}_e + \mathbf{E}_p \quad , \quad (6.135)$$

$$\mathbf{T} = (1 - D)^q \mathcal{C}[\mathbf{E}_e] \quad , \quad (6.136)$$

$$\boldsymbol{\xi} = (1 - D)^q c \mathbf{Y} \quad , \quad (6.137)$$

$$R = (1 - D)^q \gamma r \quad , \quad (6.138)$$

$$F = \bar{F}(\mathbf{T}, \boldsymbol{\xi}, R, D) = (1 - D)^{-n} \left\{ \sqrt{\frac{3}{2}(\mathbf{T} - \boldsymbol{\xi})^D \cdot (\mathbf{T} - \boldsymbol{\xi})^D} - R \right\} - k_0 \quad , \quad (6.139)$$

$$\text{plastic loading} \Leftrightarrow F = 0 \quad \& \quad (\dot{F})_{\mathbf{E}_p = \text{const}} > 0 \quad , \quad (6.140)$$

$$\dot{\mathbf{E}}_p = \frac{3\dot{s}}{2} \frac{(\mathbf{T} - \boldsymbol{\xi})^D}{(1 - D)^n k_0 + R} \quad , \quad (6.141)$$

$$\dot{\mathbf{Y}} = \dot{\mathbf{E}}_p - b\dot{s} \frac{\boldsymbol{\xi}}{m} = \dot{\mathbf{E}}_p - b c m \dot{s} \mathbf{Y} \quad , \quad (6.142)$$

$$\dot{r} = \left(1 - \beta \frac{R}{m} \right) \dot{s} = (1 - \beta \gamma m r) \dot{s} \quad . \quad (6.143)$$

Characteristic properties of the model may be highlighted by considering uniaxial tensile loading. For this case, one finds from (6.135)–(6.143) that during plastic flow the following equations hold

$$\varepsilon = \varepsilon_e + \varepsilon_p \quad , \quad (6.144)$$

$$\sigma = (1 - D)^q E \varepsilon_e \quad , \quad (6.145)$$

$$\xi = (1 - D)^q c y \quad , \quad (6.146)$$

$$R = (1 - D)^q \gamma r \quad , \quad (6.147)$$

$$\sigma - \frac{3}{2} \xi = R + (1 - D)^n k_0 \quad , \quad (6.148)$$

$$\dot{y} = \left[1 - b c (1 - D)^{\frac{q}{2}} y \right] \dot{\varepsilon}_p \quad , \quad (6.149)$$

$$\dot{r} = \left[1 - \beta \gamma (1 - D)^{\frac{q}{2}} r \right] \dot{\varepsilon}_p \quad , \quad (6.150)$$

where we have used the same nomenclature as in Section 6.4. To make the analysis as simple as possible, we first concentrate to the damage law (6.82). To see if ε_e will be remain bounded also for this model, we solve from (6.145)–(6.148) for ε_e :

$$\varepsilon_e = \frac{3c}{2E} y + \frac{\gamma}{E} r + \frac{k_0}{E} (1 - D)^{n-q} \quad . \quad (6.151)$$

Clearly, for ideal plasticity, Equation (6.151) reduces to

$$\varepsilon_e = \frac{k_0}{E} (1 - D)^{n-q} \quad . \quad (6.152)$$

Since $\varepsilon_p \leq \alpha$, y and r will be remain bounded, in view of (6.149), (6.150). Therefore, as $D \rightarrow 1$, ε_e will remain bounded too, if and only if $n \geq q$. We believe that, at least for metallic materials, the elastic strain should be bounded as $D \rightarrow 1$. Hence, we will focus attention on cases $n \geq q$. (Some parameter studies for $q = 1$ and the damage law (6.82) have been reported in [137].)

6.6.1 Comparison of the models according to strain and energy equivalence

In order to compare the model according to the proposed energy equivalence principle with the model according to the strain equivalence principle, we set $n = q = 1$. For this case, the resulting elastic

strain (6.151) is identical to that one for the model due the strain equivalence principle in Equation (6.84). Moreover, the only differences between the two models consist in the evolution equations governing kinematic and isotropic hardening, while uniaxial responses predicted by the two models are nearly identical. The question may then arise, whether this is true for arbitrary loading processes indicating inhomogeneous deformations. To clarify this question, we assume equal material parameters for both models, as given in Table 6.2. In the calculations, we use the more realistic evolution law

$$\dot{D} = \alpha_1 \frac{\left(-\rho \frac{\partial \Psi}{\partial D}\right)^p}{(1-D)^K} \dot{s} \quad , \quad (6.153)$$

where α_1 , p , K are non-negative material parameters. Equation (6.153) goes back to Lemaitre [104], who introduced such laws in order to model ductile damage.

Tabelle 6.2: Material parameters used for calculating the responses in Figures 6.2 and 6.3

E [MPa]	k_0 [MPa]	r_0	c [MPa]	γ [MPa]	b [MPa]	β [MPa]	α_1	q
200000	400	0	10000	10000	10	10	1	0

To avoid the well-known problem of mesh dependencies in the softening regime, we focus attention to viscoplasticity, which regularizes the equations of plasticity. A simple case of viscoplasticity arises by defining \dot{s} to be given by

$$\dot{s} = \frac{\langle F \rangle^{m^*}}{\eta} \quad (6.154)$$

rather than to be determined from the consistency condition $\dot{F} = 0$. In (6.154), $\langle x \rangle$ denotes the function

$$\langle x \rangle := \begin{cases} x & \text{if } x \geq 0 \\ 0 & \text{if } x < 0 \end{cases} \quad , \quad (6.155)$$

for real x . In the ensuing analysis, the material parameters m^* and η are chosen to be $m^* = 2, 5$, $\eta = 2 \cdot 10^8 (MPa)s$. As can be seen in Figure 6.2, the uniaxial responses for the two constitutive models are nearly identical. Next we consider a notched circular cylinder tensile specimen, subjected to prescribed displacement along the upper boundaries. The predicted responses have been calculated by employing the ABAQUS finite element code. This provides a user subroutine, in which the two models have been implemented. The finite element mesh and the imposed loading used, are shown in Figure 6.4. Because of various symmetry conditions, only a quarter of the specimen has been meshed with 117 eight-node axial symmetric solid elements. Figure 6.3 illustrates for the two models the radial distribution of the damage variable D , with r being the radius in the plane through the notch root. The results are referred to the overall resulting strain (global strain) $e^* = \frac{L-L_0}{L_0}$, where L , L_0 are the current and initial length of the inhomogeneously deformed specimen. It can be seen that for $e_0^* = 0, 2\%$ both models predict identical radial distributions. Some noticeable quantitative differences between the response predicted by the two models may be recognized for $e_2^* = 0, 356\%$ and $\frac{r}{r_0} = 0, 6$.

As mentioned in the Introduction, the strain equivalence principle has been turned out to be well established for isotropic damage. From the results above we recognize that, for the range of material

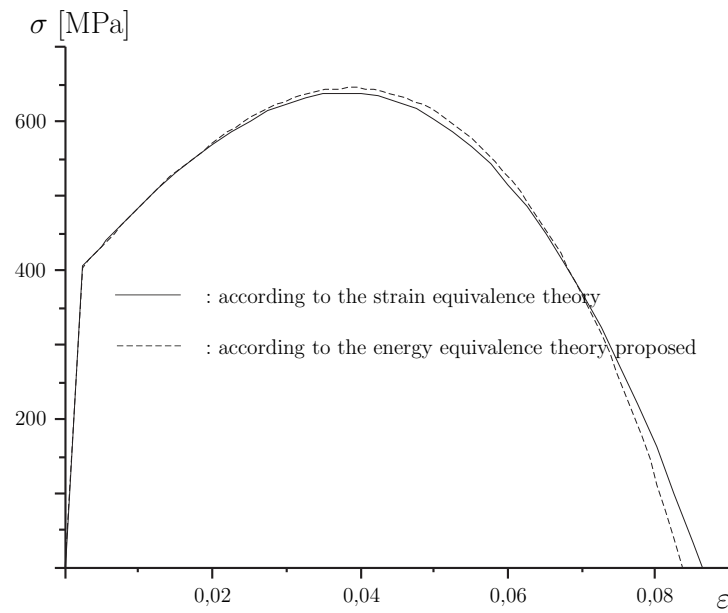

Figure 6.2: Uniaxial tensile responses predicted by the two models.

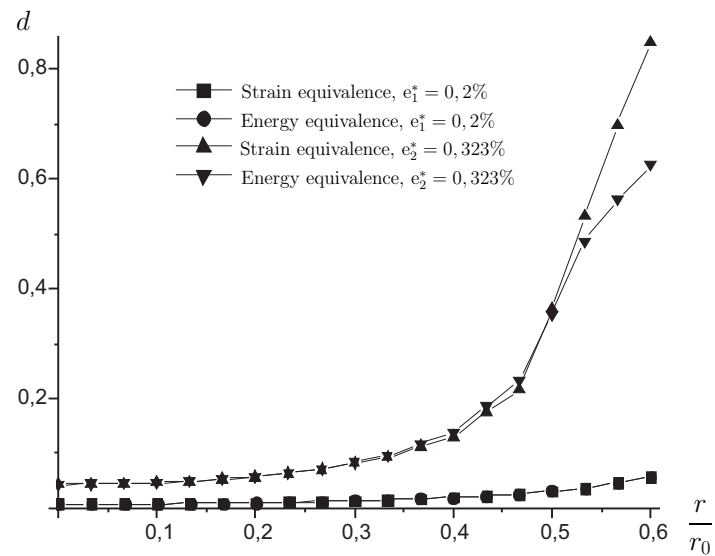

Figure 6.3: Radial distribution of the damage variable D through the notch root for $e_1^* = 0,2\%$ and $e_2^* = 0,323\%$.

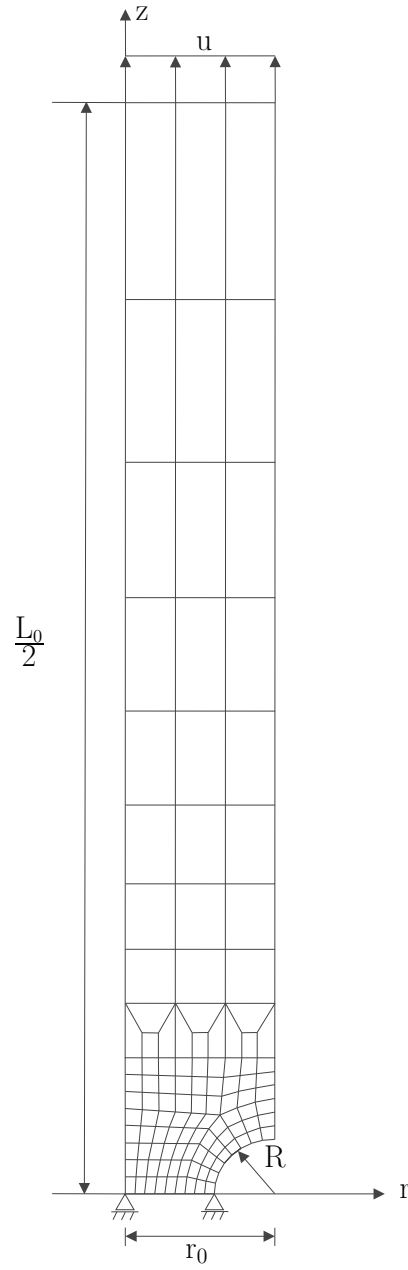

Figure 6.4: Circular notched specimen. The assigned material parameters are given in Table 6.2.

parameters considered, the two theories predict comparable responses. Thus, when isotropic damage effects are addressed, both theories can be employed equally to describe material behavior. However, whenever anisotropic damage is concerned, continuum damage models based on energy equivalence principles seem to be more suitable, for symmetric stiffness tensors are involved in a natural way in the models based on energy principles. Therefore, we shall employ in Part II the energy equivalence method developed here to formulate anisotropic damage effects in material response. Beforehand, it is of interest to elucidate how material parameters affect the form of strain-stress responses predicted by the model resulting from the proposed energy equivalence principle.

6.6.2 Parameter studies

We recall that $n \geq q$ ensures bounded elastic strains as $D \rightarrow 1$. On the other hand, $n > 1$ may be considered to be not a realistic assumption for metallic materials. To support this supposition, we confine ourselves once more to the case of ideal plasticity, for which Equation (6.152) applies. If $n > q$, then $\lim_{\varepsilon_e \rightarrow 0} \varepsilon_e \rightarrow 0$ as $D \rightarrow 1$. This contradicts our expectation that ε_e should be constant until local rupture. In other words, we believe that the lattice distortion of the elastic ideal plastic material will remain constant during plastic flow, independent of the damage evolution. Hence, one might conclude that for metallic materials $n = q$ should be chosen.

The parameter studies illustrated in Figures 6.5–6.11 are referred to the damage law (6.153). Accordingly, damage evolution is coupled to plastic flow. More sophisticated damage laws have been proposed e.g. in Lemaitre [106], but to elaborate these in the present context is beyond of the scope.

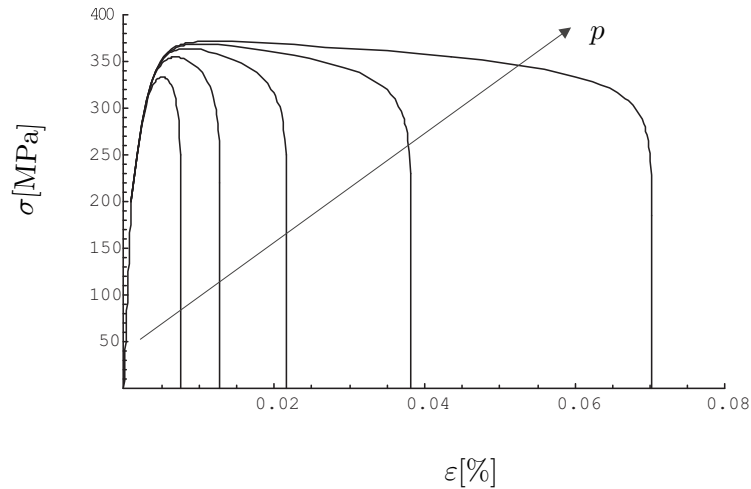

Figure 6.5: ε - σ -graphs corresponding to the material parameters $n = q = 1$, $\alpha = 50$, $k = 9$, $p \in \{2, 3, 4, 5, 6\}$.

Figures 6.5–6.11 reveal that for $n = q > 1$ the ε - σ -graphs are concave everywhere or may exhibit concave and convex regions, depending on the values of the material parameters in the evolution law for damage. If $n = q = 1$, however, then the graphs remain concave everywhere independent on the values of the materials parameters on the damage evolution law.

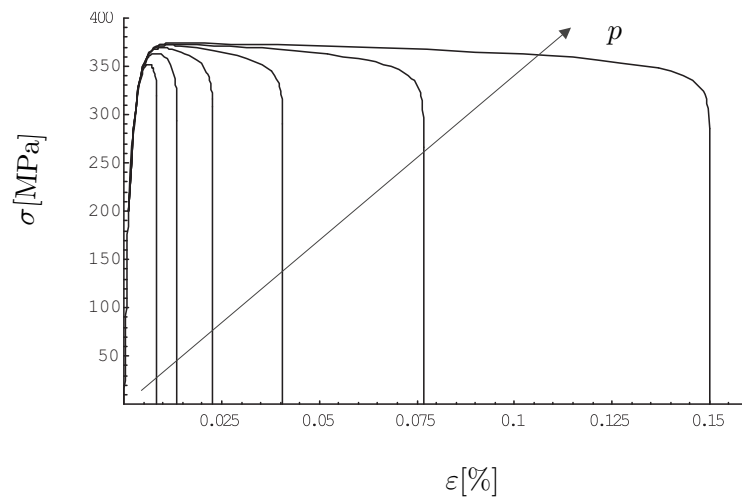

Figure 6.6: ϵ - σ -graphs corresponding to the material parameters $n = q = 1$, $\alpha = 50$, $k = 20$, $p \in \{1, 2, 3, 4, 5, 6\}$.

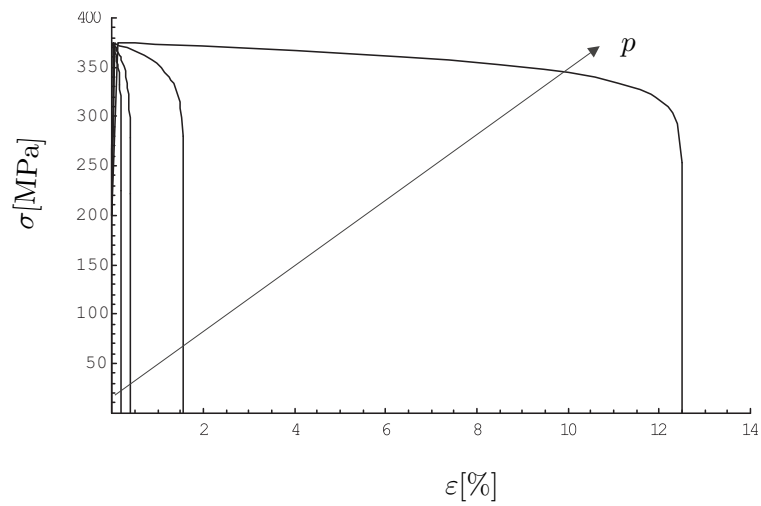

Figure 6.7: ϵ - σ -graphs corresponding to the material parameters $n = q = 1$, $\alpha = 1$, $k = 9$, $p \in \{1, 2, 3, 4\}$.

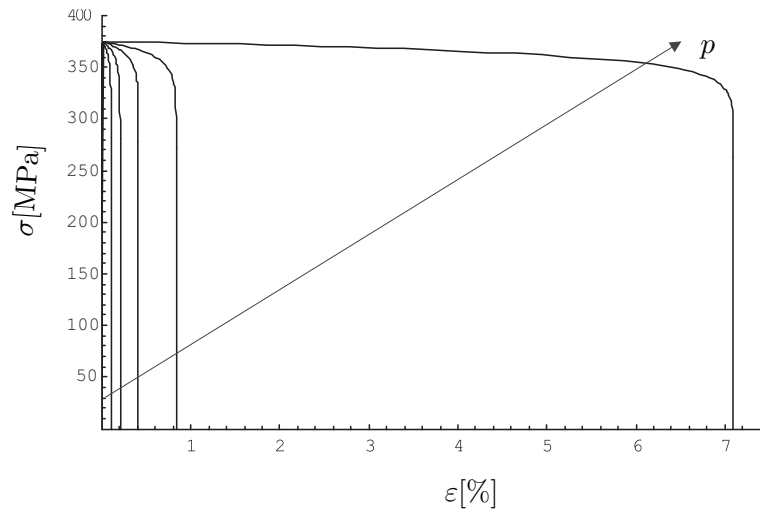

Figure 6.8: ε - σ -graphs corresponding to the material parameters $n = q = 1$, $\alpha = 1$, $k = 20$, $p \in \{1, 2, 3, 4, 5\}$.

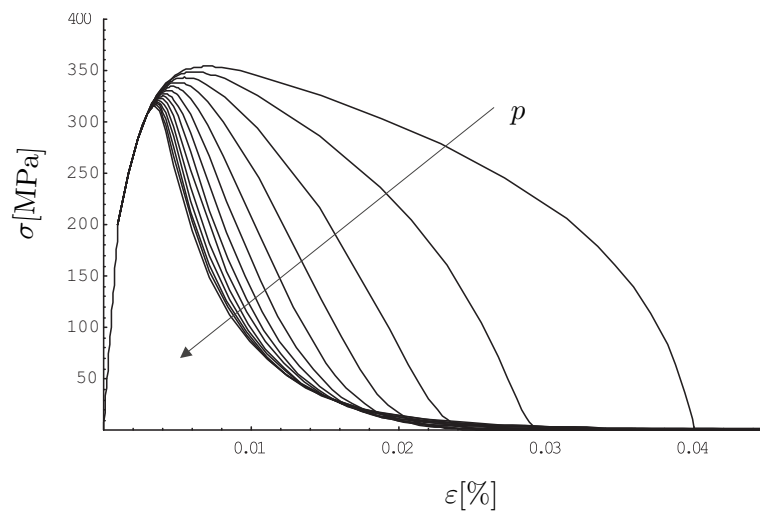

Figure 6.9: ε - σ -graphs corresponding to the material parameters $n = q = 4$, $\alpha = 1$, $k = 9$, $p \in \{2, 3, 4, 5, 6, 7, 8, 9, 10, 11, 12, 14, 15\}$.

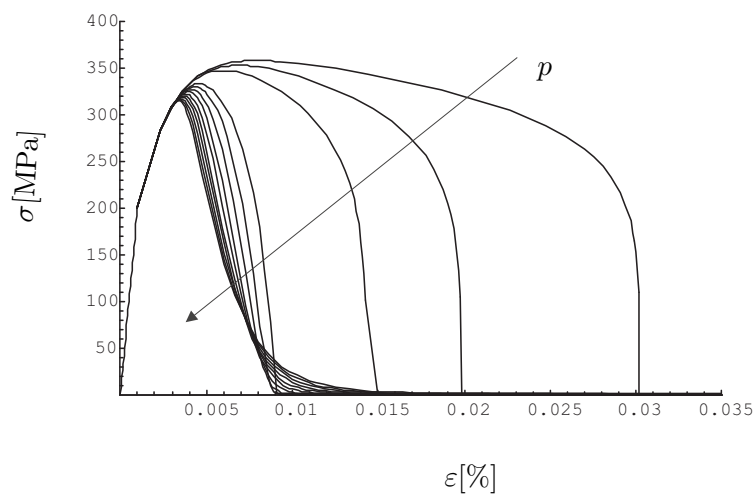

Figure 6.10: ε - σ -graphs corresponding to the material parameters $n = q = 4$, $\alpha = 1$, $k = 20$, $p \in \{1, 2, 3, 7, 8, 9, 10, 11, 12, 13, 14, 15\}$.

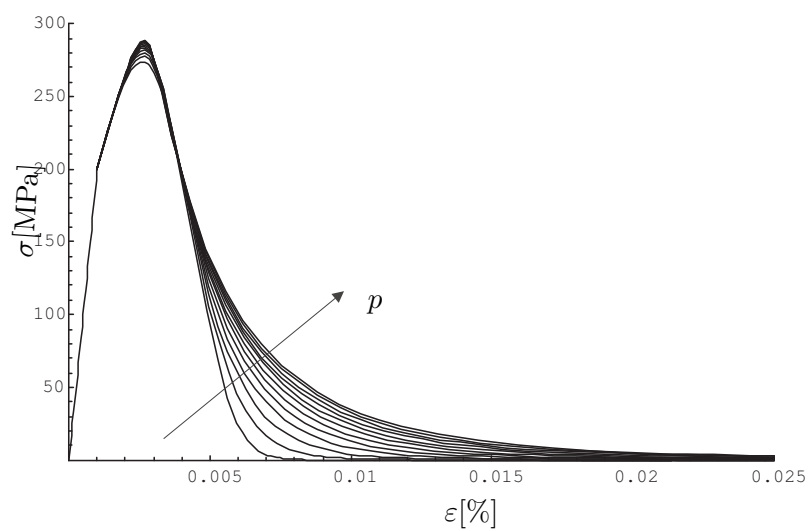

Figure 6.11: ε - σ -graphs corresponding to the material parameters $n = q = 4$, $\alpha = 50$, $k = 9$, $p \in \{3, 4, 5, 6, 7, 8, 9, 10, 11, 12, 13, 14, 15\}$.

6.7 Concluding remarks

An energy equivalence principle for isotropic damage has been proposed, which furnishes, among others, a family of yield functions parameterized by n . Effective stress and strain variables are parameterized by q . Plausibility arguments seem to impose for metallic materials the condition $n = q$. The most important feature in our approach was the definition of the effective variable \dot{s}^{ef} in Equations (6.90), combined with the equivalence of the stress powers in Equations (6.112)–(6.114). For rate-independent plasticity, one can achieve the same results by requiring alternatively the equivalence

$$\bar{w}_p(\dot{s}, \mathbf{T}, \boldsymbol{\xi}, R, D) = \frac{1}{\chi} \tilde{w}_p(\dot{s}^{ef}, \mathbf{T}^{ef}, \boldsymbol{\xi}^{ef}, R^{ef}) \quad , \quad (6.156)$$

$$\bar{w}_{kin}(\dot{s}, \mathbf{T}, \boldsymbol{\xi}, R, D) = \frac{1}{\chi} \tilde{w}_{kin}(\dot{s}^{ef}, \mathbf{T}^{ef}, \boldsymbol{\xi}^{ef}, R^{ef}) \quad , \quad (6.157)$$

$$\bar{w}_{is}(\dot{s}, \mathbf{T}, \boldsymbol{\xi}, R, D) = \frac{1}{\chi} \tilde{w}_{is}(\dot{s}^{ef}, \mathbf{T}^{ef}, \boldsymbol{\xi}^{ef}, R^{ef}) \quad , \quad (6.158)$$

where χ is a scalar valued function of state variables. After inserting e.g., in Equation (6.156), we get

$$\frac{\dot{s}}{\zeta} \mathbf{T} \cdot \frac{\partial \bar{f}(\mathbf{T} - \boldsymbol{\xi}, R, D)}{\partial (\mathbf{T} - \boldsymbol{\xi})} = \frac{\dot{s}^{ef}}{\chi \zeta^{ef}} \frac{1}{m} \mathbf{T}^{ef} \cdot \frac{\partial \tilde{f}(\mathbf{T}^{ef} - \boldsymbol{\xi}^{ef}, R^{ef})}{\partial (\mathbf{T}^{ef} - \boldsymbol{\xi}^{ef})} \quad . \quad (6.159)$$

It is now convenient to define \dot{s}^{ef} by

$$\frac{\dot{s}^{ef}}{\zeta^{ef}} := g \frac{\dot{s}}{\zeta} \chi \quad , \quad (6.160)$$

with g given by (6.92). It is then straightforward to prove that conditions (6.156)–(6.158) together with (6.160) lead to the same results derived in the previous sections, without being necessary to specify χ further. Also the physical motivation for postulating (6.156)–(6.158) and (6.160) is in line with that given after Equation (6.108). Actually, this form of the energy equivalence principle has been proposed in Reckwerth and Tsakmakis [137]. However, when viscoplasticity with dynamic recovery terms in the hardening laws is addressed, the two methods are no more equivalent to each other and the function χ has to be defined explicitly. Since, in such cases the equivalence conditions (6.156)–(6.158) and (6.160) provide more flexibility for modeling constitutive properties, we shall adopt in Part II this version of the principle.

7 Continuum damage models based on energy equivalence. Part II: Anisotropic material response

P. Grammenoudis, D. Reckwerth, Ch. Tsakmakis

**International Journal of Damage Mechanics, 18
(2009), 65-91**

Continuum damage models based on energy equivalence. Part II: Anisotropic material response

P. Grammenoudis^{*}, D. Reckwerth[°], Ch. Tsakmakis^{*}

^{*}Darmstadt University of Technology, Institute of Continuum Mechanics,
Hochschulstraße 1, 64289 Darmstadt, Germany

[°]Continental Teves AG & Co. oHG, Guerickestr. 7, 60488 Frankfurt am Main, Germany

Abstract

Anisotropic viscoplasticity coupled with anisotropic damage is modeled in a thermodynamically consistent way. Isotropic and kinematic hardening are present in the viscoplasticity part of the model and the evolution equations for the hardening variables incorporate both, static and dynamic recovery terms. Damage effects are captured in the framework of the concept of effective stress and effective strain combined with the principle of energy equivalence as adopted in Part I. The theory is employed to determine stress distributions for a single-crystal superalloy under complex loading histories. The results are compared with experimental measurements in order to examine the capabilities of the proposed theory.

7.1 Introduction

A continuum damage theory based on the hypothesis of energy equivalence has been introduced in Part I for isotropic constitutive properties. The main difference to other approaches was that the yield function was not assumed to be known, even if it is expressed in terms of effective variables. Actually, the form of the yield function results from the energy equivalence principle together with the constitutive relations for the underlying fictitious model material. For the sake of simplicity only rate-independent plasticity has been discussed essentially in Part I. In the present article we shall extend the theory to take into account, on the one hand, viscoplasticity with static recovery terms in the evolution equations for the hardening variables. On the other hand, anisotropic material properties are assumed to exist in both the viscoplastic part and the damage part of the model. A general structure of anisotropy is considered, formulated with the aid of fourth-order tensors in the elasticity law, the yield function and the kinematic hardening law. But it is straightforward to extend the formulations to cover other kinds of anisotropy. The specific form of cubic anisotropy is elaborated, in order to refer to experimental measurements. Following well-established methods in the literature, damage anisotropy is modelled by using the concept of the damage effect tensor in the definition of the so-called effective variables. The resulting system of constitutive equations is employed to calculate stress distributions for a single-crystal superalloy subject to complex loading histories. Comparison with experimental data enables to estimate the capabilities of the proposed theory. Throughout the article, the nomenclature

and the fundamental assumptions of Section 6.2 in Part I apply, while component representations are referred to a Cartesian coordinate system.

7.2 Viscoplasticity part of the model

7.2.1 General anisotropic structure

In the absence of damage, the constitutive properties of the material to be modeled are supposed to be captured by the following system of equations describing viscoplasticity:

$$\mathbf{E} = \mathbf{E}_e + \mathbf{E}_p \quad , \quad (7.1)$$

$$\tilde{\Psi}(\mathbf{E}_e, \mathbf{Y}, r) = \tilde{\Psi}_e(\mathbf{E}_e) + \tilde{\Psi}_p(\mathbf{Y}, r) \quad , \quad (7.2)$$

$$\tilde{\Psi}_e(\mathbf{E}_e) = \frac{1}{2\rho} \mathbf{E}_e \cdot \mathbf{C}[\mathbf{E}_e] \quad , \quad (7.3)$$

$$\mathcal{C}_{ijkl} = \mathcal{C}_{jikl} = \mathcal{C}_{klij} \quad , \quad (7.4)$$

$$\tilde{\Psi}_p(\mathbf{Y}, r) = \tilde{\Psi}_p^{kin}(\mathbf{Y}) + \tilde{\Psi}_p^{is}(r) \quad , \quad (7.5)$$

$$\tilde{\Psi}_p^{kin}(\mathbf{Y}) = \frac{1}{2\rho} \mathbf{Y} \cdot \mathcal{N}[\mathbf{Y}] \quad , \quad (7.6)$$

$$\mathcal{N}_{ijkl} = \mathcal{N}_{jikl} = \mathcal{N}_{klij} \quad , \quad \mathcal{N}_{ijkk} = 0 \quad \Leftrightarrow \quad \mathcal{N}[\mathbf{1}] = \mathbf{0} \quad , \quad (7.7)$$

$$\tilde{\Psi}_p^{is}(r) = \frac{\gamma}{2\rho} r^2 \quad , \quad (7.8)$$

$$\boldsymbol{\xi} := \rho \frac{\partial \tilde{\Psi}_p^{kin}}{\partial \mathbf{Y}} = \mathcal{N}[\mathbf{Y}] \quad , \quad (7.9)$$

$$R := \rho \frac{\partial \tilde{\Psi}_p^{is}}{\partial r} = \gamma r \quad , \quad (7.10)$$

$$r(t=0) = 0 \quad , \quad R(t=0) = 0 \quad , \quad (7.11)$$

$$\tilde{F}(\mathbf{T}, \boldsymbol{\xi}, R) := \tilde{f}(\mathbf{T} - \boldsymbol{\xi}, R) - k_0 \quad : \quad \text{yield function} \quad , \quad (7.12)$$

$$\tilde{f}(\mathbf{T} - \boldsymbol{\xi}, R) := \sqrt{\frac{3}{2}(\mathbf{T} - \boldsymbol{\xi})^D \cdot \mathcal{K}[(\mathbf{T} - \boldsymbol{\xi})^D]} - R \equiv \sqrt{\frac{3}{2}(\mathbf{T} - \boldsymbol{\xi}) \cdot \mathcal{K}[\mathbf{T} - \boldsymbol{\xi}]} - R \quad , \quad (7.13)$$

$$\mathcal{K}_{ijkl} = \mathcal{K}_{jikl} = \mathcal{K}_{klij} \quad \Leftrightarrow \quad \mathcal{K} = \mathcal{K}^T \quad , \quad \mathcal{K}_{ijkk} = 0 \quad \Leftrightarrow \quad \mathcal{K}[\mathbf{1}] = \mathbf{0} \quad , \quad (7.14)$$

$$\dot{s} = \frac{\langle \tilde{F}(\mathbf{T}, \boldsymbol{\xi}, R) \rangle^{m^*}}{\eta} \quad . \quad (7.15)$$

Flow rule:

$$\dot{\mathbf{E}}_p = \tilde{\mathbf{f}}_p(\dot{s}, \mathbf{T}, \boldsymbol{\xi}, R) := \frac{\dot{s}}{\zeta} \frac{\partial \tilde{F}}{\partial \mathbf{T}} = \frac{\dot{s}}{\zeta} \frac{\partial \tilde{f}}{\partial (\mathbf{T} - \boldsymbol{\xi})} = \frac{3\dot{s}}{2\zeta} \frac{\mathcal{K}[\mathbf{T} - \boldsymbol{\xi}]}{\tilde{f} + R} \quad , \quad (7.16)$$

$$\dot{s} = \sqrt{\frac{2}{3} \dot{\mathbf{E}}_p \cdot \dot{\mathbf{E}}_p} \quad , \quad (7.17)$$

$$\zeta = \tilde{f}_\zeta(\mathbf{T} - \boldsymbol{\xi}, R) := \sqrt{\frac{2}{3} \frac{\partial \tilde{f}}{\partial (\mathbf{T} - \boldsymbol{\xi})} \cdot \frac{\partial \tilde{f}}{\partial (\mathbf{T} - \boldsymbol{\xi})}} = \frac{1}{\tilde{f} + R} \sqrt{\frac{3}{2} \mathcal{K}[\mathbf{T} - \boldsymbol{\xi}] \cdot \mathcal{K}[\mathbf{T} - \boldsymbol{\xi}]} \quad . \quad (7.18)$$

Clausius-Duhem inequality:

$$\mathbf{T} \cdot \dot{\mathbf{E}} - \rho \frac{d}{dt} \tilde{\Psi} = \mathbf{T} \cdot \dot{\mathbf{E}} + \mathbf{T} \cdot \dot{\mathbf{E}}_p - \rho \frac{d}{dt} \tilde{\Psi}_e - \rho \frac{d}{dt} \tilde{\Psi}_p \geq 0 \quad , \quad (7.19)$$

$$\mathbf{T} = \rho \frac{\partial \tilde{\Psi}_e}{\partial \mathbf{E}_e} = \mathcal{C}[\mathbf{E}_e] \quad : \quad \text{elasticity law} \quad . \quad (7.20)$$

Dissipation inequality:

$$\mathcal{D} := \mathbf{T} \cdot \dot{\mathbf{E}}_p - \rho \frac{d}{dt} \tilde{\Psi}_p = \mathbf{T} \cdot \dot{\mathbf{E}}_p - \boldsymbol{\xi} \cdot \dot{\mathbf{Y}} - R\dot{r} = (\mathbf{T} - \boldsymbol{\xi}) \cdot \dot{\mathbf{E}}_p - R\dot{r} + \boldsymbol{\xi} \cdot (\dot{\mathbf{E}}_p - \dot{\mathbf{Y}}) \geq 0 \quad . \quad (7.21)$$

Kinematic hardening rule:

$$\dot{\mathbf{Y}} = \tilde{\mathbf{f}}_{\mathbf{Y}}(\dot{s}, \mathbf{T}, \boldsymbol{\xi}, R) = \dot{\mathbf{E}}_p - \frac{\dot{s}}{\zeta} \mathcal{Q}[\boldsymbol{\xi}] - \|\boldsymbol{\xi}\|^w \mathcal{B}[\boldsymbol{\xi}] \quad , \quad (7.22)$$

$$\mathcal{Q}_{ijkl} = \mathcal{Q}_{jikl} = \mathcal{Q}_{klij} \quad , \quad \mathcal{Q}_{ijkk} = 0 \quad , \quad (7.23)$$

$$\mathcal{B}_{ijkl} = \mathcal{B}_{jikl} = \mathcal{B}_{klij} \quad , \quad \mathcal{B}_{ijkk} = 0 \quad . \quad (7.24)$$

Isotropic hardening rule:

$$\dot{r} = \tilde{f}_r(\dot{s}, \mathbf{T}, \boldsymbol{\xi}, R) = (1 - \beta R) \frac{\dot{s}}{\zeta} - \pi R^\omega \quad . \quad (7.25)$$

Equation (7.1) is the decomposition of the strain tensor \mathbf{E} into elastic and plastic parts, $\tilde{\Psi}$ is the specific free energy function, ρ is the mass density and \mathcal{C} the fourth-order elasticity tensor. Compared to Part I, differences are present in the free energy functions $\tilde{\Psi}_e$, $\tilde{\Psi}_p^{kin}$, the yield function \tilde{F} (respectively \tilde{f}) and the evolution equations for the hardening variables. The components of the fourth-order tensors \mathcal{C} , \mathcal{N} , \mathcal{K} , \mathcal{Q} , \mathcal{B} as well as w , π , ω represent material parameters. Especially, \mathcal{C} , \mathcal{K} are supposed to be positive definite, while \mathcal{N} , \mathcal{Q} , \mathcal{B} denote positive semi-definite tensors. According to Equation (7.15), plastic flow occurs whenever a positive overstress \tilde{F} exists, with m^* , η and $\langle \cdot \rangle$ being material parameters and scalar valued function as explained in Section 6.6.1 of Part I. The yield surface $\tilde{f} = k_0$ represents essentially a so-called quadratic criterion, anisotropy being induced by the tensor \mathcal{K} . Such quadratic criteria have been used in modelling anisotropic plasticity for example by [130, 132, 133]. In order to check up compatibility of the hardening rules with the second law (7.19), we substitute Equation (7.16) into (7.19), to get

$$\tilde{\mathcal{D}} = \frac{\dot{s}}{\zeta} (\mathbf{T} - \boldsymbol{\xi}) \cdot \frac{\partial \tilde{f}}{\partial (\mathbf{T} - \boldsymbol{\xi})} - R\dot{r} + \boldsymbol{\xi} \cdot (\dot{\mathbf{E}}_p - \dot{\mathbf{Y}}) \quad . \quad (7.26)$$

This can be recasted by introducing the function

$$\tilde{h}(\mathbf{T} - \boldsymbol{\xi}) := \sqrt{\frac{3}{2} (\mathbf{T} - \boldsymbol{\xi}) \cdot \mathcal{K} [\mathbf{T} - \boldsymbol{\xi}]} \equiv \tilde{f} + R \quad , \quad (7.27)$$

with the property

$$\frac{\partial \tilde{h}}{\partial (\mathbf{T} - \boldsymbol{\xi})} = \frac{\partial \tilde{f}}{\partial (\mathbf{T} - \boldsymbol{\xi})} \quad . \quad (7.28)$$

As \tilde{h} is a convex function of $(\mathbf{T} - \boldsymbol{\xi})$, we have

$$\tilde{h}(\mathbf{0}) - \tilde{h}(\mathbf{T} - \boldsymbol{\xi}) - \{\mathbf{0} - (\mathbf{T} - \boldsymbol{\xi})\} \cdot \frac{\partial \tilde{h}(\mathbf{T} - \boldsymbol{\xi})}{\partial (\mathbf{T} - \boldsymbol{\xi})} > 0 \quad , \quad (7.29)$$

or

$$\frac{\partial \tilde{h}}{\partial(\mathbf{T} - \boldsymbol{\xi})} \cdot (\mathbf{T} - \boldsymbol{\xi}) > \tilde{h}(\mathbf{T} - \boldsymbol{\xi}) \quad , \quad (7.30)$$

and therefore

$$\frac{\partial \tilde{f}}{\partial(\mathbf{T} - \boldsymbol{\xi})} \cdot (\mathbf{T} - \boldsymbol{\xi}) > \tilde{f} + R \quad . \quad (7.31)$$

After inserting into (7.26),

$$\tilde{D} > \frac{\dot{s}}{\zeta} \tilde{f} + R \left(\frac{\dot{s}}{\zeta} - \dot{r} \right) + \boldsymbol{\xi} \cdot (\dot{\mathbf{E}}_p - \dot{\mathbf{Y}}) \quad . \quad (7.32)$$

During plastic flow we have $\tilde{f} \geq k_0$, so that $\frac{\dot{s}}{\zeta} \tilde{f} \geq 0$. Consequently,

$$\boldsymbol{\xi} \cdot (\dot{\mathbf{E}}_p - \dot{\mathbf{Y}}) \geq 0 \quad , \quad (7.33)$$

$$R \left(\frac{\dot{s}}{\zeta} - \dot{r} \right) \geq 0 \quad (7.34)$$

are sufficient conditions for the dissipation inequality $\tilde{D} \geq 0$. Latter are always satisfied if

$$\dot{\mathbf{E}}_p - \dot{\mathbf{Y}} = \frac{\dot{s}}{\zeta} \mathcal{Q}[\boldsymbol{\xi}] + \|\boldsymbol{\xi}\|^w \mathcal{B}[\boldsymbol{\xi}] \quad , \quad (7.35)$$

$$\frac{\dot{s}}{\zeta} - \dot{r} = \beta \frac{\dot{s}}{\zeta} R + \pi R^\omega \quad , \quad (7.36)$$

which are identical to Equations (7.22) and (7.25), respectively. Of course, some other non-negative scalar functions of $\boldsymbol{\xi}$ and R^ω could be utilized in (7.35) and (7.36) instead of $\|\boldsymbol{\xi}\|^w$ and R^ω , respectively, but this is not pursuit here. The first terms on the right side of (7.35) and (7.36) denote dynamic recovery terms, while the second terms represent static recovery terms. As in Part I, the stress powers $\mathbf{T} \cdot \dot{\mathbf{E}}_p$, $\boldsymbol{\xi} \cdot \dot{\mathbf{Y}}$ and $R\dot{r}$ may be thought to be given by constitutive functions \tilde{w}_p , \tilde{w}_{kin} and \tilde{w}_{is} , respectively:

$$\tilde{w}_p(\dot{s}, \mathbf{T}, \boldsymbol{\xi}, R) := \mathbf{T} \cdot \tilde{\mathbf{f}}_p(\dot{s}, \mathbf{T}, \boldsymbol{\xi}, R) = \frac{\dot{s}}{\zeta} \mathbf{T} \cdot \frac{\partial \tilde{f}(\mathbf{T} - \boldsymbol{\xi}, R)}{\partial(\mathbf{T} - \boldsymbol{\xi})} \quad , \quad (7.37)$$

$$\tilde{w}_{kin}(\dot{s}, \mathbf{T}, \boldsymbol{\xi}, R) := \boldsymbol{\xi} \cdot \tilde{\mathbf{f}}_Y(\dot{s}, \mathbf{T}, \boldsymbol{\xi}, R) = \boldsymbol{\xi} \cdot \left\{ \tilde{\mathbf{f}}_p(\dot{s}, \mathbf{T}, \boldsymbol{\xi}, R) - \frac{\dot{s}}{\zeta} \mathcal{Q}[\boldsymbol{\xi}] - \|\boldsymbol{\xi}\|^w \mathcal{B}[\boldsymbol{\xi}] \right\} \quad , \quad (7.38)$$

$$\tilde{w}_{is}(\dot{s}, \mathbf{T}, \boldsymbol{\xi}, R) := R \tilde{f}_r(\dot{s}, \mathbf{T}, \boldsymbol{\xi}, R) = R \left\{ (1 - \beta R) \frac{\dot{s}}{\zeta} - \pi R^\omega \right\} \quad . \quad (7.39)$$

7.2.2 Cubic symmetry

For later reference we discuss here the specific form of the tensors \mathcal{C} , \mathcal{N} , \mathcal{K} , \mathcal{Q} , \mathcal{B} for the case of cubic symmetry. Let $\boldsymbol{\chi}$ be any one of these tensors and \mathbf{S} , \mathbf{P} symmetric second-order tensors, so that

$$\mathbf{P} = \boldsymbol{\chi}[\mathbf{S}] \quad . \quad (7.40)$$

Using vector notation,

$$P_i = \chi_{ij} S_j \quad , \quad (7.41)$$

where the vectors P_i, S_j are given by

$$P_i = \begin{pmatrix} P_{11} \\ P_{22} \\ P_{33} \\ P_{23} \\ P_{13} \\ P_{12} \end{pmatrix}, \quad S_j = \begin{pmatrix} S_{11} \\ S_{22} \\ S_{33} \\ S_{23} \\ S_{13} \\ S_{12} \end{pmatrix}, \quad (7.42)$$

and the 6×6 Matrix χ_{ij} has components

$$\chi_{ij} = \begin{pmatrix} \chi_{11} & \chi_{12} & \chi_{13} & \chi_{14} & \chi_{15} & \chi_{16} \\ \chi_{12} & \chi_{22} & \chi_{23} & \chi_{24} & \chi_{25} & \chi_{26} \\ \chi_{13} & \chi_{23} & \chi_{33} & \chi_{34} & \chi_{35} & \chi_{36} \\ \chi_{14} & \chi_{24} & \chi_{34} & \chi_{44} & \chi_{45} & \chi_{46} \\ \chi_{15} & \chi_{25} & \chi_{35} & \chi_{45} & \chi_{55} & \chi_{56} \\ \chi_{16} & \chi_{26} & \chi_{36} & \chi_{46} & \chi_{56} & \chi_{66} \end{pmatrix}. \quad (7.43)$$

If the material possess cubic symmetry, then there are Cartesian coordinates $\{x'_i\}$ relative to which χ_{ij} has the form

$$\chi_{ij} = \begin{pmatrix} \chi_{11} & \chi_{12} & \chi_{12} & 0 & 0 & 0 \\ \chi_{12} & \chi_{11} & \chi_{12} & 0 & 0 & 0 \\ \chi_{12} & \chi_{12} & \chi_{11} & 0 & 0 & 0 \\ 0 & 0 & 0 & \chi_{44} & 0 & 0 \\ 0 & 0 & 0 & 0 & \chi_{44} & 0 \\ 0 & 0 & 0 & 0 & 0 & \chi_{44} \end{pmatrix}. \quad (7.44)$$

Moreover, the components of $\mathcal{N}, \mathcal{K}, \mathcal{Q}, \mathcal{B}$ exhibit the condition $\chi_{11} + 2\chi_{12} = 0$, in view of (7.7), (7.14), (7.23), (7.24).

Viscoplasticity for materials with cubic symmetry has been modeled also by [130, 132, 133]. Differences to these works consist in the equation for \dot{s} and the equations for isotropic and kinematic hardening. Otherwise the concepts adopted here are similar to that ones for viscoplasticity advocated by Chaboche and fall into the framework of irreversible thermodynamics. It is worth noting that, as elucidated by [131], quadratic yield criteria seem to be inconvenient to describe accurately some torsional loadings of single crystals with cubic symmetry. But generally the material responses predicted in several tests were very encouraging, as reported by [130]. We decided to develop our theory with reference to a quadratic yield criterion, in order to get as simple as possible formulations. Nonquadratic criteria will be involved in further work.

7.3 Coupling with damage – energy equivalence principle

Within continuum damage mechanics, anisotropic damage can conveniently be reflected by using as variables second-order damage tensors (see Skrzypek [146], Chaboche [21] and the literature cited there). Accordingly, we amplify the set of variables in the previous sections by adding the symmetric second-order damage tensor \mathbf{D} . Let $D_i, i = 1, 2, 3$ be the eigenvalues of \mathbf{D} . In the undamaged state $\mathbf{D} = \mathbf{0}$. In the case of local rupture anyone D_i approaches 0, which may be captured by $\det(\mathbf{1} - \mathbf{D}) \rightarrow 0$.

Then, the material behavior may be characterized by the following constitutive relations:

$$\mathbf{E} = \mathbf{E}_e + \mathbf{E}_p \quad . \quad (7.45)$$

Free energy functions:

$$\Psi(t) = \bar{\Psi}(\mathbf{E}_e, \mathbf{Y}, r, \mathbf{D}) = \Psi_e(t) + \Psi_p(t) \quad , \quad \Psi_p(t) = \Psi_p^{kin}(t) + \Psi_p^{is}(t) \quad , \quad (7.46)$$

$$\Psi_e(t) = \bar{\Psi}_e(\mathbf{E}_e, \mathbf{D}) \quad , \quad \Psi_p^{kin}(t) = \bar{\Psi}_p^{kin}(\mathbf{Y}, \mathbf{D}) \quad , \quad \Psi_p^{is}(t) = \bar{\Psi}_p^{is}(r, \mathbf{D}) \quad . \quad (7.47)$$

Conjugate forces $\boldsymbol{\xi}$, R , $\boldsymbol{\Omega}$:

$$\boldsymbol{\xi} := \varrho \frac{\partial \bar{\Psi}_p^{kin}}{\partial \mathbf{Y}} \quad , \quad R := \varrho \frac{\partial \bar{\Psi}_p^{is}}{\partial r} \quad , \quad \boldsymbol{\Omega} := -\varrho \frac{\partial \bar{\Psi}}{\partial \mathbf{D}} \quad , \quad (7.48)$$

$$r(t=0) = 0 \quad , \quad R(t=0) = 0 \quad . \quad (7.49)$$

Yield function:

$$F(t) = \bar{F}(\mathbf{T}, \boldsymbol{\xi}, R, \mathbf{D}) = \bar{f}(\mathbf{T} - \boldsymbol{\xi}, R, \mathbf{D}) - k_0 \geq 0 \quad (7.50)$$

Evolution laws:

$$\dot{\mathbf{E}}_p = \bar{\mathbf{f}}_p(\dot{s}, \mathbf{T}, \boldsymbol{\xi}, R, \mathbf{D}) := \frac{\dot{s}}{\zeta} \frac{\partial \bar{F}}{\partial \mathbf{T}} = \frac{\dot{s}}{\zeta} \frac{\partial \bar{f}}{\partial (\mathbf{T} - \boldsymbol{\xi})} \quad , \quad (7.51)$$

$$\dot{\mathbf{Y}} = \bar{\mathbf{f}}_Y(\dot{s}, \mathbf{T}, \boldsymbol{\xi}, R, \mathbf{D}) \quad , \quad (7.52)$$

$$\dot{r} = \bar{f}_r(\dot{s}, \mathbf{T}, \boldsymbol{\xi}, R, \mathbf{D}) \quad , \quad (7.53)$$

$$\dot{s} = \sqrt{\frac{2}{3} \dot{\mathbf{E}}_p \cdot \dot{\mathbf{E}}_p} := \frac{\langle \bar{F}(\mathbf{T}, \boldsymbol{\xi}, R, \mathbf{D}) \rangle^{m^*}}{\eta} \quad , \quad (7.54)$$

$$\zeta = \bar{f}_\zeta(\mathbf{T} - \boldsymbol{\xi}, R, \mathbf{D}) := \sqrt{\frac{2}{3} \frac{\partial \bar{f}}{\partial (\mathbf{T} - \boldsymbol{\xi})} \cdot \frac{\partial \bar{f}}{\partial (\mathbf{T} - \boldsymbol{\xi})}} \quad . \quad (7.55)$$

Clausius-Duhem inequality:

$$\bar{\mathcal{D}} := \mathbf{T} \cdot \dot{\mathbf{E}} - \varrho \dot{\Psi}_e - \varrho \dot{\Psi}_p^{kin} - \varrho \dot{\Psi}_p^{is} \geq 0 \quad . \quad (7.56)$$

Elasticity law:

$$\mathbf{T} = \varrho \frac{\partial \bar{\Psi}_e}{\partial \mathbf{E}_e} \quad . \quad (7.57)$$

Dissipation inequality:

$$\bar{\mathcal{D}}_d := \mathbf{T} \cdot \dot{\mathbf{E}}_p - \boldsymbol{\xi} \cdot \dot{\mathbf{Y}} - R\dot{r} - \varrho \frac{\partial \bar{\Psi}}{\partial \mathbf{D}} \cdot \dot{\mathbf{D}} \geq 0 \quad . \quad (7.58)$$

Separation of $\bar{\mathcal{D}}_d$:

$$\bar{\mathcal{D}}_{dp} := \mathbf{T} \cdot \dot{\mathbf{E}}_p - \boldsymbol{\xi} \cdot \dot{\mathbf{Y}} - R\dot{r} = (\mathbf{T} - \boldsymbol{\xi}) \cdot \dot{\mathbf{E}}_p - R\dot{r} + \boldsymbol{\xi} \cdot (\dot{\mathbf{E}}_p - \dot{\mathbf{Y}}) \geq 0 \quad , \quad (7.59)$$

$$\bar{\mathcal{D}}_{dd} := -\varrho \frac{\partial \bar{\Psi}}{\partial \mathbf{D}} \cdot \dot{\mathbf{D}} = \boldsymbol{\Omega} \cdot \dot{\mathbf{D}} \geq 0 \quad . \quad (7.60)$$

Stress powers:

$$\bar{w}_p(\dot{s}, \mathbf{T}, \boldsymbol{\xi}, R, \mathbf{D}) := \mathbf{T} \cdot \bar{\mathbf{f}}_p(\dot{s}, \mathbf{T}, \boldsymbol{\xi}, R, \mathbf{D}) = \frac{\dot{s}}{\zeta} \mathbf{T} \cdot \frac{\partial \bar{f}(\mathbf{T} - \boldsymbol{\xi}, R, \mathbf{D})}{\partial(\mathbf{T} - \boldsymbol{\xi})} , \quad (7.61)$$

$$\bar{w}_{kin}(\dot{s}, \mathbf{T}, \boldsymbol{\xi}, R, \mathbf{D}) := \boldsymbol{\xi} \cdot \bar{\mathbf{f}}_Y(\dot{s}, \mathbf{T}, \boldsymbol{\xi}, R, \mathbf{D}) , \quad (7.62)$$

$$\bar{w}_{is}(\dot{s}, \mathbf{T}, \boldsymbol{\xi}, R, \mathbf{D}) := R \bar{f}_r(\dot{s}, \mathbf{T}, \boldsymbol{\xi}, R, \mathbf{D}) . \quad (7.63)$$

It is perhaps of interest to remark that $\dot{\mathbf{E}}_p$, as defined in (7.51) and (7.54), is a function of state variables only (it does not depend on rates). Therefore, using standard arguments in thermodynamics, the elasticity law (7.57) and the dissipation inequality (7.58) are necessary and sufficient conditions for the validity of the Clausius-Duhem-inequality (7.56). On the other hand, (7.59) and (7.60) are only sufficient conditions for the dissipation inequality (7.58). The aim now is to find out the unknown functions $\bar{\Psi}$, \bar{f} , $\bar{\mathbf{f}}_p$, $\bar{\mathbf{f}}_Y$ and \bar{f}_r with the help of the energy equivalence principle.

7.3.1 Energy equivalence principle

A general energy equivalence principle for modeling damage effects has been proposed in Part I, which for the constitutive functions of the present article requires for the free energy functions and the stress powers the relations

$$\bar{\Psi}_e(\mathbf{E}_e, \mathbf{D}) = \tilde{\Psi}_e(\mathbf{E}_e^{ef}) = \frac{1}{2\rho} \mathbf{E}_e^{ef} \cdot \mathcal{C}[\mathbf{E}_e^{ef}] , \quad (7.64)$$

$$\bar{\Psi}_p^{(kin)}(\mathbf{Y}, \mathbf{D}) = \tilde{\Psi}_p^{(kin)}(\mathbf{Y}^{ef}) = \frac{1}{2\rho} \mathbf{Y}^{ef} \cdot \mathcal{N}[\mathbf{Y}^{ef}] , \quad (7.65)$$

$$\bar{\Psi}_p^{(is)}(r, \mathbf{D}) = \tilde{\Psi}_p^{(is)}(r^{ef}) = \frac{\gamma}{2\rho} (r^{ef})^2 \quad (7.66)$$

and

$$\bar{w}_p(\dot{s}, \mathbf{T}, \boldsymbol{\xi}, R, \mathbf{D}) = \frac{1}{\chi} \tilde{w}_p(\dot{s}^{ef}, \mathbf{T}^{ef}, \boldsymbol{\xi}^{ef}, R^{ef}) , \quad (7.67)$$

$$\bar{w}_{kin}(\dot{s}, \mathbf{T}, \boldsymbol{\xi}, R, \mathbf{D}) = \frac{1}{\chi} \tilde{w}_{kin}(\dot{s}^{ef}, \mathbf{T}^{ef}, \boldsymbol{\xi}^{ef}, R^{ef}) , \quad (7.68)$$

$$\bar{w}_{is}(\dot{s}, \mathbf{T}, \boldsymbol{\xi}, R, \mathbf{D}) = \frac{1}{\chi} \tilde{w}_{is}(\dot{s}^{ef}, \mathbf{T}^{ef}, \boldsymbol{\xi}^{ef}, R^{ef}) , \quad (7.69)$$

where χ is assumed to here to be scalar valued function of \mathbf{D} , and in particular of $\det(\mathbf{1} - \mathbf{D})$. Clearly, in the absence of damage $\chi = 1$ must be satisfied. We choose

$$\chi = (\det(\mathbf{1} - \mathbf{D}))^{-l} \quad (7.70)$$

with $l \geq 0$. Furthermore, we set

$$\frac{\dot{s}^{ef}}{\zeta^{ef}} = g \frac{\dot{s}}{\zeta} \chi , \quad (7.71)$$

with

$$g = \{\det(\mathbf{1} - \mathbf{D})\}^{\frac{g-2n}{6}} , \quad (7.72)$$

$$\zeta^{ef} = \tilde{f}_\zeta(\mathbf{T}^{ef} - \boldsymbol{\xi}^{ef}, R^{ef}) \quad , \quad \zeta = \bar{f}_\zeta(\mathbf{T} - \boldsymbol{\xi}, R, \mathbf{D}) \quad . \quad (7.73)$$

To accomplish the energy equivalence principle, it remains to introduce proper effective stress and strain variables. When assigning effective counterparts to second-order tensorial variables, like the stress tensor, a common method in continuum damage mechanics is to employ so-called damage effect tensors (cf. e.g., [146, 21]). These are functions of \mathbf{D} , and represent regular fourth-order tensors, which act on the tensorial state variable to generate the effective one. Authors advocating continuum damage mechanics argue that \mathbf{D} reflects on the macroscopic level some volume averages or even averages itself, which summarize measures of defects on the microscale, like "nucleation and coalescence of voids, cavities and microcracks" (see [25]). The anisotropy effect of damage on the material behavior is then induced by the damage effect tensor. Especially, we deal with the following definitions of effective variables here:

$$\mathbf{T}^{ef} := \mathcal{M}^{-1}[\mathbf{T}] \quad , \quad \mathbf{E}_e^{ef} := \mathcal{H}[\mathbf{E}_e] \quad , \quad (7.74)$$

$$\boldsymbol{\xi}^{ef} := \mathcal{M}^{-1}[\boldsymbol{\xi}] \quad , \quad \mathbf{Y}^{ef} := \mathcal{H}[\mathbf{Y}] \quad , \quad (7.75)$$

$$R^{ef} := \frac{R}{m} \quad , \quad r^{ef} := hr \quad , \quad (7.76)$$

where

$$\mathcal{M} = \mathcal{M}(\mathbf{D}) \quad , \quad \mathcal{H} = \mathcal{H}(\mathbf{D}) \quad , \quad m = m(\mathbf{D}) \quad , \quad h = h(\mathbf{D}) \quad . \quad (7.77)$$

The damage effect tensor \mathcal{M} and the damage effect scalar m are supposed to be given functions of \mathbf{D} , whereas the damage effect tensor \mathcal{H} and the scalar h must be determined on the basis of the energy equivalence principle. The precise form of $\mathcal{M}(\mathbf{D})$ is a matter of convenience and, combined with the evolution law of \mathbf{D} , should reflect appropriately the experimental observations. Interesting contributions to the definition of \mathcal{M} can be found, among others, in [29, 25, 23, 164, 169]. Keeping in mind Equations (6.89) and (6.92) of Part I, we choose here

$$\mathcal{M}_{ijmn} = \frac{1}{2} \left[\left((1 - \mathbf{D})^{\frac{q}{4}} \right)_{im} \left((1 - \mathbf{D})^{\frac{q}{4}} \right)_{jn} + \left((1 - \mathbf{D})^{\frac{q}{4}} \right)_{in} \left((1 - \mathbf{D})^{\frac{q}{4}} \right)_{jm} \right] \quad , \quad (7.78)$$

$$m(\mathbf{D}) = \{ \det(\mathbf{1} - \mathbf{D}) \}^{\frac{q}{6}} \quad . \quad (7.79)$$

It can readily shown, that

$$\mathcal{M}_{ijmn} = \mathcal{M}_{jimn} = \mathcal{M}_{ijnm} \quad , \quad (7.80)$$

$$\mathcal{M}_{ijmn} = \mathcal{M}_{mni j} \quad \Leftrightarrow \quad \mathcal{M} = \mathcal{M}^T \quad , \quad (7.81)$$

and that, for a symmetric second-order tensor $\mathbf{X} = \mathbf{X}^T$,

$$\mathcal{M}[\mathbf{X}] = (1 - \mathbf{D})^{\frac{q}{4}} \mathbf{X} (1 - \mathbf{D})^{\frac{q}{4}} \quad , \quad (7.82)$$

$$\mathcal{M}^{-1}[\mathbf{X}] = (1 - \mathbf{D})^{-\frac{q}{4}} \mathbf{X} (1 - \mathbf{D})^{-\frac{q}{4}} \quad . \quad (7.83)$$

Consequently,

$$\mathbf{T}^{ef} = (1 - \mathbf{D})^{-\frac{q}{4}} \mathbf{T} (1 - \mathbf{D})^{-\frac{q}{4}} \quad , \quad (7.84)$$

$$\boldsymbol{\xi}^{ef} = (1 - \mathbf{D})^{-\frac{q}{4}} \boldsymbol{\xi} (1 - \mathbf{D})^{-\frac{q}{4}} \quad . \quad (7.85)$$

Evidently, the particular case of isotropic damage is included for $\mathbf{1} - \mathbf{D} = (1 - D)\mathbf{1} \Rightarrow \det(\mathbf{1} - \mathbf{D}) = (1 - D)^3$, from which we recover the relations of Part I. In the ensuing analysis, no use is made of the symmetry $\mathcal{M} = \mathcal{M}^T$, in order to address more general cases. Note that the reason for operating here with \mathcal{M} defined by (7.78) (respectively (7.82)), is the simple form of $\mathcal{M}^{-1}[\mathbf{X}]$ in Equation (7.83).

7.3.2 Free energy functions

Invoking the relations

$$\mathbf{T}^{ef} = \rho \frac{\partial \tilde{\Psi}_e(\mathbf{E}_e^{ef})}{\partial \mathbf{E}_e^{ef}} = \mathbf{C}[\mathbf{E}_e^{ef}] \quad , \quad (7.86)$$

$$\boldsymbol{\xi}^{ef} = \rho \frac{\partial \tilde{\Psi}_p^{kin}(\mathbf{Y}^{ef})}{\partial \mathbf{Y}^{ef}} = \mathcal{N}[\mathbf{Y}^{ef}] \quad , \quad (7.87)$$

$$R^{ef} = \rho \frac{\partial \tilde{\Psi}_p^{is}(r^{ef})}{\partial r^{ef}} = \gamma r^{ef} \quad , \quad (7.88)$$

and using the identities

$$\frac{\partial \bar{\Psi}_e}{\partial (\mathbf{E}_e)_{ij}} = \frac{\partial \tilde{\Psi}_e}{\partial (\mathbf{E}_e^{ef})_{kl}} \mathcal{H}_{klij} \quad , \quad \frac{\partial \bar{\Psi}_e}{\partial D_{ij}} = \frac{\partial \tilde{\Psi}_e}{\partial (\mathbf{E}_e^{ef})_{kl}} \frac{\partial \mathcal{H}_{klmn}}{\partial D_{ij}} (\mathbf{E}_e)_{mn} \quad , \quad (7.89)$$

$$\frac{\partial \bar{\Psi}_p^{kin}}{\partial Y_{ij}} = \frac{\partial \tilde{\Psi}_p^{kin}}{\partial (\mathbf{Y}^{ef})_{kl}} \mathcal{H}_{klij} \quad , \quad \frac{\partial \bar{\Psi}_p^{kin}}{\partial D_{ij}} = \frac{\partial \tilde{\Psi}_p^{kin}}{\partial (\mathbf{Y}^{ef})_{kl}} \frac{\partial \mathcal{H}_{klmn}}{\partial D_{ij}} Y_{mn} \quad , \quad (7.90)$$

$$\frac{\partial \bar{\Psi}_p^{is}}{\partial r} = \frac{\partial \tilde{\Psi}_p^{is}}{\partial r^{ef}} h \quad , \quad \frac{\partial \bar{\Psi}_p^{is}}{\partial D_{ij}} = \frac{\partial \tilde{\Psi}_p^{is}}{\partial r^{ef}} \frac{\partial h}{\partial D_{ij}} r \quad , \quad (7.91)$$

which are referred to an orthonormal basis system, it can be seen that

$$\mathcal{H}(\mathbf{D}) = \mathcal{M}^T(\mathbf{D}) \quad , \quad h(\mathbf{D}) = m(\mathbf{D}) \quad , \quad (7.92)$$

and

$$\bar{\Psi}_e(\mathbf{E}_e, \mathbf{D}) = \frac{1}{2\rho} \mathbf{E}_e \cdot \mathcal{M} \mathbf{C} \mathcal{M}^T [\mathbf{E}_e] = \frac{1}{2\rho} (1 - \mathbf{D})^{\frac{q}{4}} \mathbf{E}_e (1 - \mathbf{D})^{\frac{q}{4}} \cdot \mathbf{C} [(1 - \mathbf{D})^{\frac{q}{4}} \mathbf{E}_e (1 - \mathbf{D})^{\frac{q}{4}}] \quad , \quad (7.93)$$

$$\bar{\Psi}_p^{(kin)}(\mathbf{Y}, \mathbf{D}) = \frac{1}{2\rho} \mathbf{Y} \cdot \mathcal{M} \mathcal{N} \mathcal{M}^T [\mathbf{Y}] = \frac{1}{2\rho} (1 - \mathbf{D})^{\frac{q}{4}} \mathbf{Y} (1 - \mathbf{D})^{\frac{q}{4}} \cdot \mathcal{N} [(1 - \mathbf{D})^{\frac{q}{4}} \mathbf{Y} (1 - \mathbf{D})^{\frac{q}{4}}] \quad , \quad (7.94)$$

$$\bar{\Psi}_p^{(is)}(r, \mathbf{D}) = \frac{m^2}{2\rho} \gamma r^2 = \frac{\{\det(\mathbf{1} - \mathbf{D})\}^{\frac{q}{3}}}{2\rho} \gamma r^2 \quad . \quad (7.95)$$

Consequently,

$$\mathbf{T} = \rho \frac{\partial \bar{\Psi}_e}{\partial \mathbf{E}_e} = \mathcal{M} \mathbf{C} \mathcal{M}^T [\mathbf{E}_e] \quad , \quad (7.96)$$

$$\boldsymbol{\xi} = \rho \frac{\partial \bar{\Psi}_p^{kin}}{\partial \mathbf{Y}} = \mathcal{M} \mathcal{N} \mathcal{M}^T [\mathbf{Y}] \quad , \quad (7.97)$$

$$R = \rho \frac{\partial \bar{\Psi}_p^{is}}{\partial r} = \underbrace{\{\det(\mathbf{1} - \mathbf{D})\}^{\frac{q}{3}}}_{m^2} \gamma r \quad . \quad (7.98)$$

7.3.3 Yield function – flow rule

On substituting in Equation (7.67),

$$\frac{\dot{s}}{\zeta} \mathbf{T} \cdot \frac{\partial \bar{f}(\mathbf{T} - \boldsymbol{\xi}, R, D)}{\partial (\mathbf{T} - \boldsymbol{\xi})} = \frac{\dot{s}^{ef}}{\chi \zeta^{ef}} \mathbf{T}^{ef} \cdot \frac{\partial \tilde{f}(\mathbf{T}^{ef} - \boldsymbol{\xi}^{ef}, R^{ef})}{\partial (\mathbf{T}^{ef} - \boldsymbol{\xi}^{ef})} \quad , \quad (7.99)$$

or, by virtue of (7.71), (7.74)

$$\mathbf{T} \cdot \frac{\partial \bar{f}(\mathbf{T} - \boldsymbol{\xi}, R, D)}{\partial (\mathbf{T} - \boldsymbol{\xi})} = g \mathbf{T} \cdot \mathcal{M}^{T-1} \frac{\partial \tilde{f}(\mathbf{T}^{ef} - \boldsymbol{\xi}^{ef}, R^{ef})}{\partial (\mathbf{T}^{ef} - \boldsymbol{\xi}^{ef})} . \quad (7.100)$$

Latter is satisfied if

$$\frac{\partial \bar{f}(\mathbf{T} - \boldsymbol{\xi}, R, D)}{\partial (\mathbf{T} - \boldsymbol{\xi})} = g \mathcal{M}^{T-1} \frac{\partial \tilde{f}(\mathbf{T}^{ef} - \boldsymbol{\xi}^{ef}, R^{ef})}{\partial (\mathbf{T}^{ef} - \boldsymbol{\xi}^{ef})} , \quad (7.101)$$

which posses a solution

$$\begin{aligned} \bar{f}(\mathbf{T} - \boldsymbol{\xi}, R, D) &= g \tilde{f}(\mathbf{T}^{ef} - \boldsymbol{\xi}^{ef}, R^{ef}) \\ &= g \left\{ \sqrt{\frac{3}{2}(\mathbf{T}^{ef} - \boldsymbol{\xi}^{ef}) \cdot \boldsymbol{\kappa}[\mathbf{T}^{ef} - \boldsymbol{\xi}^{ef}] - R^{ef}} \right\} \\ &= g \left\{ \sqrt{\frac{3}{2}(\mathbf{T} - \boldsymbol{\xi}) \cdot \mathcal{M}^{T-1} \boldsymbol{\kappa} \mathcal{M}^{-1}[\mathbf{T} - \boldsymbol{\xi}] - \frac{R}{m}} \right\} . \end{aligned} \quad (7.102)$$

Altogether, we get for the yield function

$$\bar{F}(\mathbf{T}, \boldsymbol{\xi}, R, D) = g \left\{ \sqrt{\frac{3}{2}(\mathbf{T} - \boldsymbol{\xi}) \cdot \mathcal{M}^{T-1} \boldsymbol{\kappa} \mathcal{M}^{-1}[\mathbf{T} - \boldsymbol{\xi}] - \frac{R}{m}} \right\} - k_0 . \quad (7.103)$$

The flow rule reads

$$\dot{\mathbf{E}}_p = \sqrt{\frac{3}{2}} \dot{s} \frac{\mathcal{M}^{T-1} \boldsymbol{\kappa} \mathcal{M}^{-1}[\mathbf{T} - \boldsymbol{\xi}]}{\left\| \sqrt{\mathcal{M}^{T-1} \boldsymbol{\kappa} \mathcal{M}^{-1}[\mathbf{T} - \boldsymbol{\xi}]} \right\|} , \quad (7.104)$$

and ζ becomes

$$\zeta = g \frac{\left\| \mathcal{M}^{T-1} \boldsymbol{\kappa} \mathcal{M}^{-1}[\mathbf{T} - \boldsymbol{\xi}] \right\|}{\sqrt{(\mathbf{T} - \boldsymbol{\xi}) \cdot \mathcal{M}^{T-1} \boldsymbol{\kappa} \mathcal{M}^{-1}[\mathbf{T} - \boldsymbol{\xi}]}} . \quad (7.105)$$

We recall that n enters in function g as parameter, so that Equation (7.103) represents a family of yield functions parameterized by n .

7.3.4 Hardening rules

It is not difficult to show, by using similar mathematical operations as in the last section (cf. also Section 6.5.2 in Part I), that relations (7.68), (7.69) furnish the hardening rules

$$\dot{\mathbf{Y}} = \dot{\mathbf{E}}_p - g \frac{\dot{s}}{\zeta} \mathcal{M}^{T-1} \boldsymbol{\varrho} \mathcal{M}^{-1}[\boldsymbol{\xi}] - \frac{1}{\chi} \left\| \mathcal{M}^{-1}[\boldsymbol{\xi}] \right\|^w \mathcal{M}^{T-1} \boldsymbol{\beta} \mathcal{M}^{-1}[\boldsymbol{\xi}] , \quad (7.106)$$

$$\dot{r} = \left(1 - \beta \frac{R}{m} \right) \frac{g \dot{s}}{m \zeta} - \frac{\pi}{\chi m} \left(\frac{R}{m} \right)^\omega . \quad (7.107)$$

We are now going to examine compatibility of the hardening rules with inequality (7.59). Keeping in mind that \mathcal{K} , and hence $\mathcal{M}^{T-1}\mathcal{K}\mathcal{M}^{-1}$ too, is positive definite, and by using similar mathematical steps as between Equation (7.27) and Equation (7.31), it is readily established that

$$(\mathbf{T} - \boldsymbol{\xi}) \cdot \frac{\partial \bar{f}}{\partial (\mathbf{T} - \boldsymbol{\xi})} > \bar{f} + g \frac{R}{m} \quad . \quad (7.108)$$

On substituting this in (7.59)

$$\bar{\mathcal{D}}_{dp} \geq \left(\bar{f} + g \frac{R}{m} \right) \frac{\dot{s}}{\zeta} - R\dot{r} + \boldsymbol{\xi} \cdot (\dot{\mathbf{E}}_p - \dot{\mathbf{Y}}) \quad , \quad (7.109)$$

or

$$\bar{\mathcal{D}}_{dp} \geq \bar{f} \frac{\dot{s}}{\zeta} + R \left(\frac{g}{m} \frac{\dot{s}}{\zeta} - \dot{r} \right) + \boldsymbol{\xi} \cdot (\dot{\mathbf{E}}_p - \dot{\mathbf{Y}}) \quad . \quad (7.110)$$

After inserting from (7.106), (7.107), and recalling that \mathcal{Q} , \mathcal{B} are positive semidefinite tensors,

$$\begin{aligned} \bar{\mathcal{D}}_{dp} &= \bar{f} \frac{\dot{s}}{\zeta} + \beta \left(\frac{R}{m} \right)^2 g \frac{\dot{s}}{\zeta} + \frac{\pi}{\chi} \left(\frac{R}{m} \right)^{\omega+1} \\ &\quad + g \frac{\dot{s}}{\zeta} \boldsymbol{\xi} \cdot \mathcal{M}^{T-1} \mathcal{Q} \mathcal{M}^{-1} [\boldsymbol{\xi}] \\ &\quad + \frac{1}{\chi} \|\mathcal{M}^{-1} [\boldsymbol{\xi}]\|^w \boldsymbol{\xi} \cdot \mathcal{M}^{T-1} \mathcal{B} \mathcal{M}^{-1} [\boldsymbol{\xi}] \geq 0 \quad , \end{aligned} \quad (7.111)$$

which proves inequality (7.59).

7.3.5 Evolution equation for damage

Inequality (7.60) will be satisfied always, if

$$\dot{\mathbf{D}} = \frac{\partial \varphi_{\mathbf{D}}}{\partial \boldsymbol{\Omega}} \quad , \quad \varphi_{\mathbf{D}} = \varphi_{\mathbf{D}}(\boldsymbol{\Omega}; \mathbf{T}, \boldsymbol{\xi}, R, \mathbf{D}) \quad , \quad (7.112)$$

where $\varphi_{\mathbf{D}}$ is a complex scalar valued function of $\boldsymbol{\Omega}$. The surface $\varphi_{\mathbf{D}} = 0$ in $\boldsymbol{\Omega}$ -space is assumed to surround a range, which includes the point $\boldsymbol{\Omega} = \mathbf{0}$, so that the scalar product $\frac{\partial \varphi_{\mathbf{D}}}{\partial \boldsymbol{\Omega}} \cdot \boldsymbol{\Omega}$ will be non-negative. For the purposes of the present work, we assume

$$\varphi_{\mathbf{D}} = \sqrt{\boldsymbol{\Omega} \cdot \mathcal{Q}_c[\boldsymbol{\Omega}]} \frac{\langle \chi_c(\mathbf{T}) \rangle^{r_c}}{A_c} (\det(\mathbf{1} - \mathbf{D}))^{-k_c} \quad , \quad (7.113)$$

$$\chi_c(\mathbf{T}) := \alpha_c T_M + \beta_c (\text{tr} \mathbf{T}) + (1 - \alpha_c - \beta_c) \sqrt{\frac{3}{2} \mathbf{T} \cdot \mathcal{M}_c[\mathbf{T}]} \quad , \quad (7.114)$$

so that

$$\dot{\mathbf{D}} = \frac{\mathcal{Q}_c[\boldsymbol{\Omega}]}{\sqrt{\boldsymbol{\Omega} \cdot \mathcal{Q}_c[\boldsymbol{\Omega}]}} \frac{\langle \chi_c(\mathbf{T}) \rangle^{r_c}}{A_c} (\det(\mathbf{1} - \mathbf{D}))^{-k_c} \quad , \quad (7.115)$$

where $\alpha_c, \beta_c, A_c, r_c, k_c$ are material parameters, $\alpha_c + \beta_c + \gamma_c = 1$, T_M denotes the maximum principal tensile stress and $\mathcal{Q}_c, \mathcal{M}_c$ are fourth-order tensors with components representing material parameters. Evolution Equation (7.112), together with damage potential functions of the form (7.113) have

been introduced by Chaboche and coworkers (see e.g. [60, 61]) in order to model creep damage. One might interpret Equation (7.115) to generalize 1D creep damage laws of Kachanov and Rabotnov (see Chaboche [21]). According to (7.113)–(7.115), damage evolution occurs whenever the damage criterion $\chi_c > 0$ is satisfied. Function $\chi_c(\mathbf{T})$ is a generalization of a corresponding damage criterion function proposed by Hayhurst [83]. Indeed, if $\mathbf{T} \cdot \mathcal{M}_c[\mathbf{T}] = \mathbf{T}^D \cdot \mathbf{T}^D$, then $\chi_c(\mathbf{T})$ in (7.114) reduces to the proposal of Hayhurst. In general cases, \mathcal{M}_c is supposed to indicate the same symmetry conditions as \mathcal{K} in Equation (7.14).

An important aspect in our approach is that \mathbf{D} appears in both parts of the free energy function, namely in $\bar{\Psi}_e$ and $\bar{\Psi}_p$. This entails an additive decomposition of the driving force $\boldsymbol{\Omega}$ (cf. Equations (7.93)–(7.95)):

$$\boldsymbol{\Omega} = \boldsymbol{\Omega}_e + \boldsymbol{\Omega}_p^{kin} + \boldsymbol{\Omega}_p^{is} \quad . \quad (7.116)$$

We shall now establish the terms on the right side of (7.116). In doing this, the derivative

$$\mathcal{D} := \frac{\partial(\mathbf{1} - \mathbf{D})^{\frac{q}{4}}}{\partial \mathbf{D}} \quad (7.117)$$

has to be determined, where \mathcal{D} indicates the symmetries

$$\mathcal{D}_{ijmn} = \mathcal{D}_{jimn} = \mathcal{D}_{ijnm} \quad . \quad (7.118)$$

If $\frac{q}{4}$ is an integer, then \mathcal{D} can be calculated in a straightforward manner:

$$\frac{q}{4} = 1 \quad : \quad \mathcal{D}_{ijmn} = -\mathcal{E}_{ijmn} \quad , \quad (7.119)$$

$$\frac{q}{4} = 2 \quad : \quad \mathcal{D}_{ijmn} = -\{\mathcal{E}_{ikmn}(\mathbf{1} - \mathbf{D})_{kj} + (\mathbf{1} - \mathbf{D})_{ik}\mathcal{E}_{kjmn}\} \quad , \quad (7.120)$$

$$\begin{aligned} \frac{q}{4} = 3 \quad : \quad \mathcal{D}_{ijmn} = & -\{\mathcal{E}_{ikmn}(\mathbf{1} - \mathbf{D})_{kr}(\mathbf{1} - \mathbf{D})_{rj} \\ & + (\mathbf{1} - \mathbf{D})_{ik}\mathcal{E}_{krmn}(\mathbf{1} - \mathbf{D})_{rj} \\ & + (\mathbf{1} - \mathbf{D})_{ik}(\mathbf{1} - \mathbf{D})_{kr}\mathcal{E}_{rjmn}\} \quad , \quad (7.121) \\ & \vdots \end{aligned}$$

If $\frac{q}{4}$ is not an integer, then closed relations may be derived with respect to the eigenvectors \mathbf{d}_i , $i = 1, 2, 3$, of \mathbf{D} . Let

$$\mathbf{D} = \sum_{i=1}^3 D_i \mathbf{d}_i \otimes \mathbf{d}_i \quad (7.122)$$

be the spectral representation of \mathbf{D} , so that

$$\boldsymbol{\Phi} := (\mathbf{1} - \mathbf{D})^{\frac{q}{4}} = \sum_{i=1}^3 \theta(D_i) \mathbf{d}_i \otimes \mathbf{d}_i \quad , \quad (7.123)$$

$$\theta(D_i) := (\mathbf{1} - \mathbf{D})^{\frac{q}{4}} \quad . \quad (7.124)$$

Denote by \mathcal{D}_{ijmn}^* the components of \mathcal{D} with respect to the basis induced by $\{\mathbf{d}_i\}$,

$$\mathcal{D} = \mathcal{D}_{ijmn}^* \mathbf{d}_i \otimes \mathbf{d}_j \otimes \mathbf{d}_m \otimes \mathbf{d}_n \quad , \quad (7.125)$$

and write $\theta'(x) = \frac{d\theta(x)}{dx}$. Then, as Ogden [134] demonstrated, the only nonvanishing components of \mathcal{D} on the basis induced by $\{\mathbf{d}_i\}$ are given by

$$\mathcal{D}_{iii}^* = \theta'(\lambda_i) \quad , \quad i = 1, 2, 3 \quad , \quad (7.126)$$

$$\mathcal{D}_{ijij}^* = \begin{cases} \frac{1}{2} \frac{\theta(D_j) - \theta(D_i)}{D_j - D_i} & \text{for } D_j \neq D_i, i \neq j \quad , \\ \frac{1}{2} \theta'(D_i) & \text{for } D_j = D_i, i \neq j \quad . \end{cases} \quad (7.127)$$

Having established tensor \mathcal{D} , the driving forces $\mathbf{\Omega}_e$, $\mathbf{\Omega}_p^{kin}$, $\mathbf{\Omega}_p^{is}$ follow from Equations (7.93)–(7.95):

$$(\mathbf{\Omega}_e)_{mn} = -\varrho \frac{\partial \bar{\Psi}_e}{\partial D_{mn}} = -\{\mathcal{D}_{krmn}(\mathbf{E}_e)_{rs} \Phi_{sl} + \Phi_{kr}(\mathbf{E}_e)_{rs} \mathcal{D}_{slmn}\} \mathcal{C}_{klij} \Phi_{ip}(\mathbf{E}_e)_{pq} \Phi_{qj} \quad , \quad (7.128)$$

$$(\mathbf{\Omega}_p^{kin})_{mn} = -\varrho \frac{\partial \bar{\Psi}_p^{kin}}{\partial D_{mn}} = -\{\mathcal{D}_{krmn} Y_{rs} \Phi_{sl} + \Phi_{kr} Y_{rs} \mathcal{D}_{slmn}\} \mathcal{N}_{klij} \Phi_{ip} Y_{pq} \Phi_{qj} \quad , \quad (7.129)$$

$$(\mathbf{\Omega}_p^{is})_{mn} = -\varrho \frac{\partial \bar{\Psi}_p^{is}}{\partial D_{mn}} = \frac{q\gamma r^2}{6} [\det(\mathbf{1} - \mathbf{D})]^{\frac{q}{3}} ((\mathbf{1} - \mathbf{D})^{-1})_{mn} \quad . \quad (7.130)$$

7.4 Examples

Parameter studies for isotropic damage in Part I demonstrated that whenever $n = q = 1$ the ε - σ -graphs are not sensible with respect to the damage evolution law and indicate everywhere a concave form. Nevertheless, in favor of a simple formulation, we set in the sequence $n = q = 4$. In fact, this choice allows a simple form for the tensors \mathcal{M}^{-1} and \mathcal{D} , so that tedious representations relative to the basis induced by the eigenvectors of \mathbf{D} can be avoided. On the whole, it is expected that this will suffice to elucidate the abilities of the constitutive theory.

The resulting model for $n = q = 4$ reads as follows:

$$\mathbf{E} = \mathbf{E}_e + \mathbf{E}_p \quad , \quad (7.131)$$

$$\mathbf{T} = \mathcal{M} \mathcal{C} \mathcal{M}^T [\mathbf{E}_e] \quad , \quad (7.132)$$

$$\boldsymbol{\xi} = \mathcal{M} \mathcal{N} \mathcal{M}^T [\mathbf{T}] \quad , \quad (7.133)$$

$$R = m^2 \gamma r \quad , \quad (7.134)$$

$$\mathcal{M}[\mathbf{X}] = (\mathbf{1} - \mathbf{D}) \mathbf{X} (\mathbf{1} - \mathbf{D}) \quad , \quad (7.135)$$

$$m = (\det(\mathbf{1} - \mathbf{D}))^{\frac{q}{6}} \quad , \quad (7.136)$$

$$g = (\det(\mathbf{1} - \mathbf{D}))^{-\frac{2}{3}} \quad , \quad (7.137)$$

$$\chi = (\det(\mathbf{1} - \mathbf{D}))^{-l} \quad , \quad (7.138)$$

$$F = g \left\{ \sqrt{\frac{3}{2} (\mathbf{T} - \boldsymbol{\xi}) \cdot \mathcal{M}^{T-1} \mathcal{K} \mathcal{M}^{-1} [\mathbf{T} - \boldsymbol{\xi}] - \frac{R}{m}} \right\} - k_0 \quad , \quad (7.139)$$

$$\dot{\mathbf{E}}_p = \sqrt{\frac{3}{2}} \dot{s} \frac{\mathcal{M}^{T-1} \mathcal{K} \mathcal{M}^{-1} [\mathbf{T} - \boldsymbol{\xi}]}{\|\mathcal{M}^{T-1} \mathcal{K} \mathcal{M}^{-1} [\mathbf{T} - \boldsymbol{\xi}]\|} \quad , \quad (7.140)$$

$$\dot{s} = \frac{\langle F \rangle^{m^*}}{\eta} \quad , \quad (7.141)$$

$$\zeta = g \frac{\|\mathcal{M}^{T-1} \mathcal{K} \mathcal{M}^{-1} [\mathbf{T} - \boldsymbol{\xi}]\|}{\sqrt{(\mathbf{T} - \boldsymbol{\xi}) \cdot \mathcal{M}^{T-1} \mathcal{K} \mathcal{M}^{-1} [\mathbf{T} - \boldsymbol{\xi}]}} \quad , \quad (7.142)$$

$$\dot{\mathbf{Y}} = \dot{\mathbf{E}}_p - g \frac{\dot{\zeta}}{\zeta} \mathcal{M}^{T-1} \mathcal{Q} \mathcal{M}^{-1} [\boldsymbol{\xi}] - \frac{1}{\chi} \|\mathcal{M}^{-1} [\boldsymbol{\xi}]\|^w \mathcal{M}^{T-1} \mathcal{B} \mathcal{M}^{-1} [\boldsymbol{\xi}] \quad , \quad (7.143)$$

$$\dot{r} = \left(1 - \beta \frac{R}{m}\right) \frac{g \dot{\zeta}}{m \zeta} - \frac{\pi}{\chi m} \left(\frac{R}{m}\right)^\omega \quad , \quad (7.144)$$

$$\dot{\mathbf{D}} = \frac{\mathcal{Q}_c[\boldsymbol{\Omega}]}{\sqrt{\boldsymbol{\Omega} \cdot \mathcal{Q}_c[\boldsymbol{\Omega}]}} \frac{\langle \chi_c(\mathbf{T}) \rangle^{r_c}}{A_c} (\det(\mathbf{1} - \mathbf{D}))^{-k_c} \quad , \quad (7.145)$$

$$\chi_c(\mathbf{T}) := \alpha_c T_M + \beta_c (\text{tr} \mathbf{T}) + (1 - \alpha_c - \beta_c) \sqrt{\frac{3}{2} \mathbf{T} \cdot \mathcal{M}_c[\mathbf{T}]} \quad , \quad (7.146)$$

$$\boldsymbol{\Omega} = \boldsymbol{\Omega}_e + \boldsymbol{\Omega}_p^{kin} + \boldsymbol{\Omega}_p^{is} \quad , \quad (7.147)$$

$$(\boldsymbol{\Omega}_e)_{mn} = \{ \mathcal{E}_{krmn} (\mathbf{E}_e)_{rs} (\mathbf{1} - \mathbf{D})_{sl} + (\mathbf{1} - \mathbf{D})_{kr} (\mathbf{E}_e)_{rs} \mathcal{E}_{slmn} \} \mathcal{C}_{klij} (\mathbf{1} - \mathbf{D})_{ip} (\mathbf{E}_e)_{pq} (\mathbf{1} - \mathbf{D})_{qj} \quad , \quad (7.148)$$

$$(\boldsymbol{\Omega}_p^{kin})_{mn} = \{ \mathcal{E}_{krmn} Y_{rs} (\mathbf{1} - \mathbf{D})_{sl} + (\mathbf{1} - \mathbf{D})_{kr} Y_{rs} \mathcal{E}_{slmn} \} \mathcal{N}_{klij} (\mathbf{1} - \mathbf{D})_{ip} Y_{pq} (\mathbf{1} - \mathbf{D})_{qj} \quad , \quad (7.149)$$

$$(\boldsymbol{\Omega}_p^{is})_{mn} = \frac{2\gamma r^2}{3} [\det(\mathbf{1} - \mathbf{D})]^{4/3} ((\mathbf{1} - \mathbf{D})^{-1})_{mn} \quad . \quad (7.150)$$

This model has been implemented into the Finite Element code ABAQUS. Predicted responses for a Ni-base single-crystal superalloy and corresponding experimental results are displayed in Figures 7.3–7.8. Cubic symmetry is assumed to apply (cf. [133, 132, 130]), and the values of the material parameters used in the calculations are given in Table 7.1. Note that these values are chosen and not determined on the basis of some professional optimization method. Application of such methods is very expensive (see e.g. [89]) and is beyond of the scope of the present article.

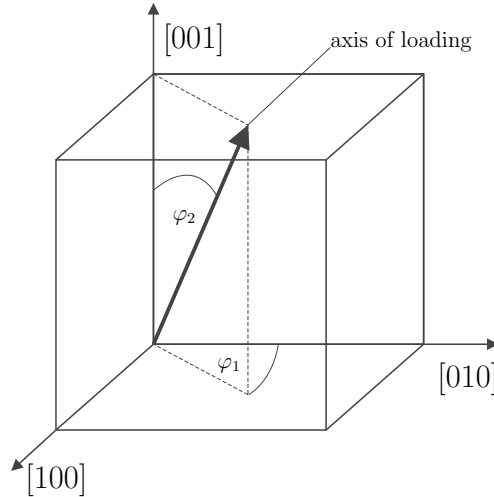

Figure 7.1: Angles φ_1 and φ_2 indicate the loading axis which coincides with the specimen axis

Tabelle 7.1: Values of the material parameters used in the calculations. The components of \mathcal{C} , \mathcal{N} , \mathcal{Q} , \mathcal{B} , \mathcal{K} , \mathcal{Q}_c and \mathcal{M}_c are denoted by C_{ij} , N_{ij} , Q_{ij} , B_{ij} , K_{ij} , Q_{cij} and M_{cij} , respectively.

material parameters					
elasticity law					
C_{11} [MPa]	97000	C_{12} [MPa]	47000	C_{44} [MPa]	100000
kinematic hardening					
N_{11} [MPa]	10000	N_{12} [MPa]	0	N_{44} [MPa]	3000
Q_{11} [MPa ⁻¹]	0,058	Q_{12} [MPa ⁻¹]	0	Q_{44} [MPa ⁻¹]	0,005
isotropic hardening					
γ [MPa]	4100	β [MPa ⁻¹]	710	k_0 [MPa]	77,67
recovery terms					
B_{11} [MPa ⁻¹]	2^{-11}	B_{12} [MPa ⁻¹]	0	B_{44} [MPa ⁻¹]	2^{-11}
w	1	π [MPa ⁻¹]	0	ω	1
1	1				
yield surface					
K_{11}	1	K_{12}	0	K_{44}	0,495
visco-plasticity					
η [MPa ^m s]	$7, 4^{12}$	m^*	3,45		
damage law					
α_c	0,4	β_c	0	n	4
A_c	$3, 5^{16}$	r_c	5,12	k_c	3
M_{c11}	0,001	M_{c12}	0	M_{c44}	1^{-6}
Q_{c11}	1	Q_{c12}	0	Q_{c44}	0,1

Tabelle 7.2: Orientation of the loading axis with respect to crystallographic axes

cyclic loading			
specimen	φ_1	φ_2	
<i>CL1</i>	42°	3, 5°	nearly [001]
<i>CL2</i>	44, 9°	50, 7°	nearly [111]

creep loading				
specimen	creep stress	φ_1	φ_2	
<i>CR1</i>	140MPa	32°	9, 1°	nearly [001]
<i>CR2</i>	95MPa	10, 3°	9, 5°	nearly [001]
<i>CR3</i>	190MPa	1°	6, 4°	nearly [001]
<i>CR4</i>	140MPa	42, 8°	52, 7°	nearly [111]
<i>CR5</i>	155MPa	42, 6°	53, 2°	nearly [111]
<i>CR6</i>	128MPa	42, 6°	53, 2°	nearly [111]

Uniaxial tension and compression loading conditions, at constant temperature of 1050°C , have been applied on specimens with circular cross-sectional area. The loading direction with respect to crystallographic axes is indicated by means of angles φ_1, φ_2 (see Figure 7.1). For the conducted experiments these angles are given in Table 7.2. First we consider strain controlled uniaxial cyclic loading, the corresponding specimens being denoted by *CL1* and *CL2*. The loading history is displayed in Figure 7.2, where z signifies the loading axis. Experimental results and predicted responses are shown in Figures 7.3–7.7. The remaining tests (Figures 7.7 and 7.8) are concerned with creep loadings at different stress levels. In spite of the fact that the material parameters are not identified on the basis of some professional optimization algorithms, Figures 7.3–7.7 confirm the capabilities of the model in predicting the experimental results without significant discrepancies. Only for creep loading near $[111]$ orientation (Figure 7.8) there are some significant qualitative and quantitative differences between measured and predicted responses. Especially, the predicted responses seem to indicate a concave form in the neighborhood of the Point O , whereas the corresponding form of the experimental results appears to be convex. It is perhaps of interest to note that qualitative differences between experimental results and predicted responses for $[111]$ oriented specimens subject to torsional loading have been also reported by [131]. These authors have argued that the differences for torsional loading arise from the quadratic yield criterion. In fact, if no quadratic criteria are employed the differences disappear. Whether the discrepancies in Figure 7.8 arise from a likely bad supposition of the material parameters or from the quadratic yield criterion adopted or from somewhat others is a question beyond of the scope of the present article and will be discussed in future work.

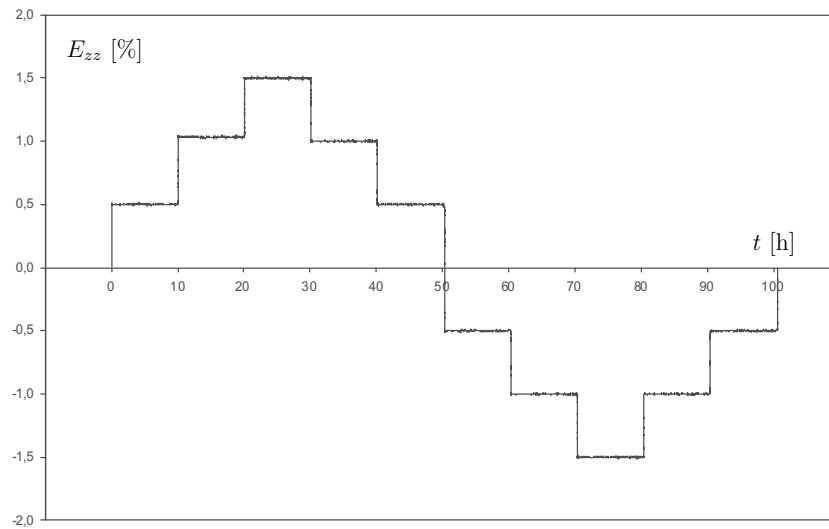

Figure 7.2: Uniaxial strain controlled loading history (specimens *CL1* and *CL2*). The strain rate amounts $0,0018\frac{1}{min}$ while all relaxation times are equal to 10 h.

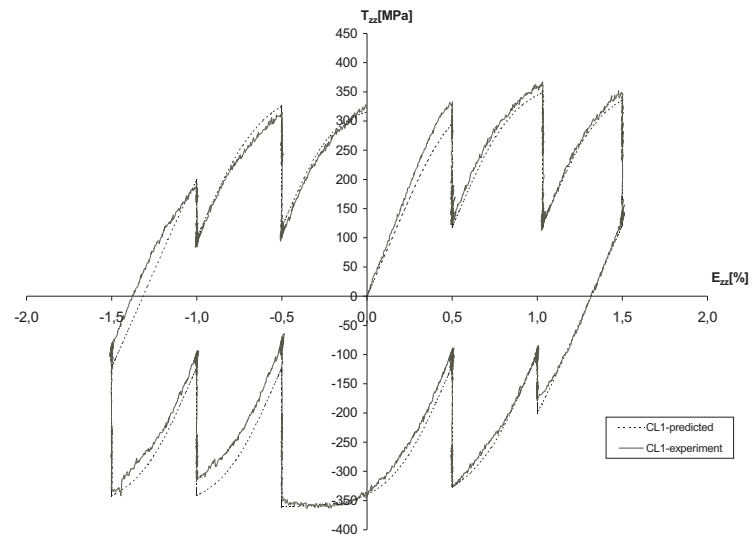

Figure 7.3: Strain-stress distribution for specimen *CL1* (near [001] orientation) according to the loading history of Figure 7.2.

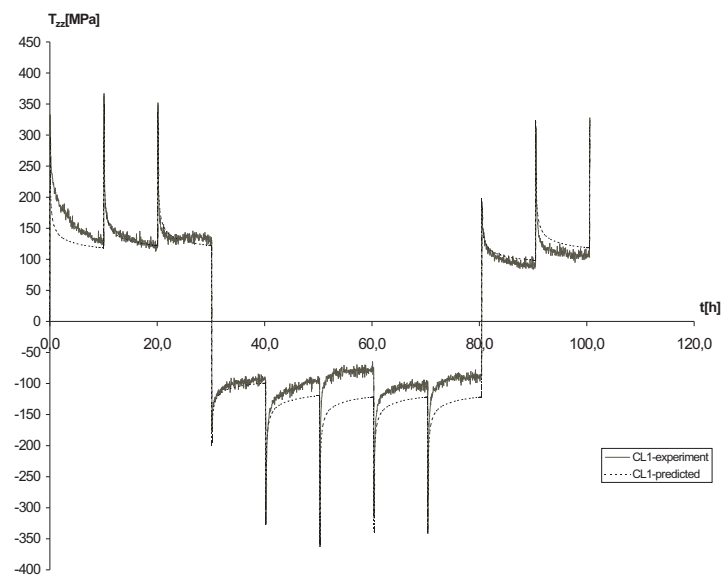

Figure 7.4: Time-stress distribution for specimen *CL1* (near [111] orientation) according to the loading history of Figure 7.2.

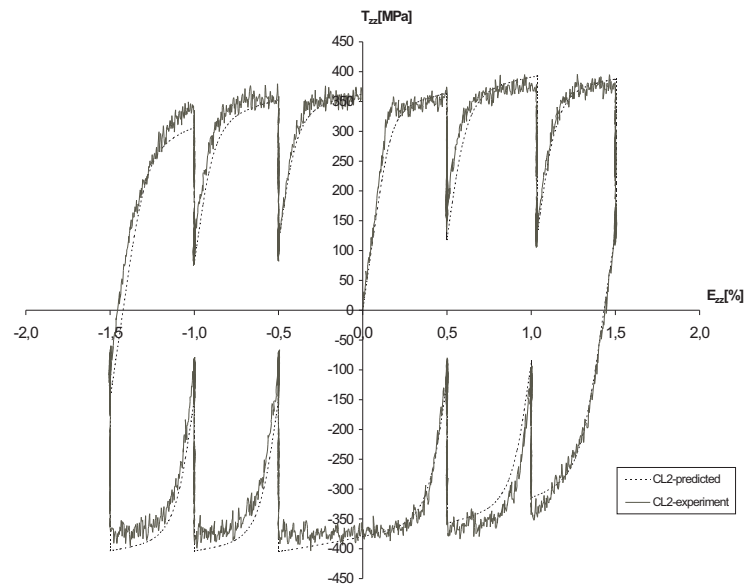

Figure 7.5: Strain-stress distribution for specimen *CL2* (near [111] orientation) according to the loading history of Figure 7.2.

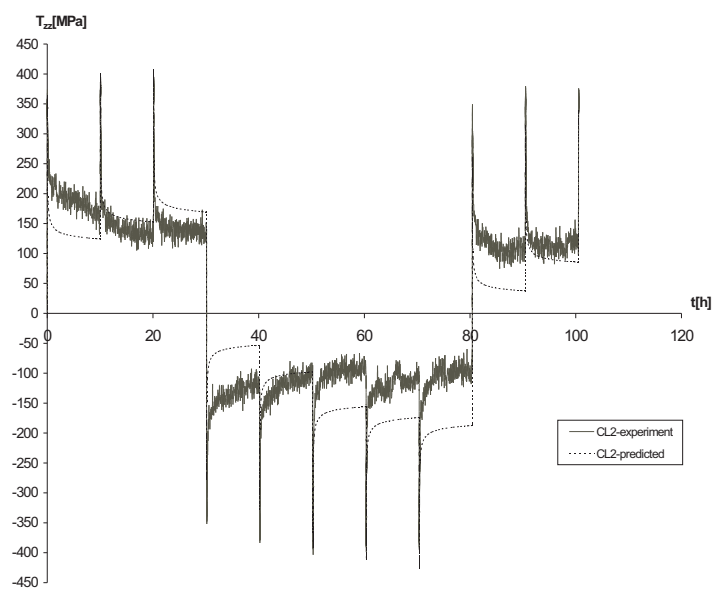

Figure 7.6: Time-stress distribution for specimen *CL2* (near [111] orientation) according to the loading history of Figure 7.2.

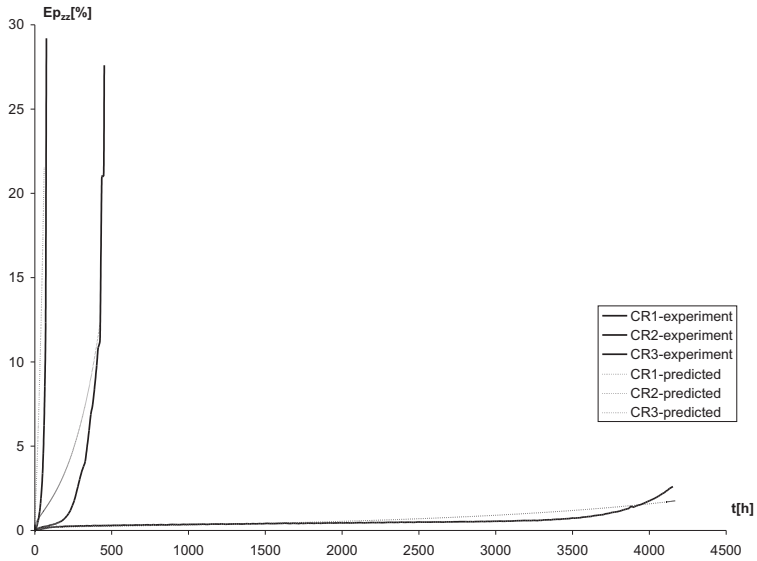

Figure 7.7: Creep loading near [001] orientation. The specimens are subject to constant stresses of $140\text{MPa}(CR1)$, $95\text{MPa}(CR2)$ and $190\text{MPa}(CR3)$, respectively.

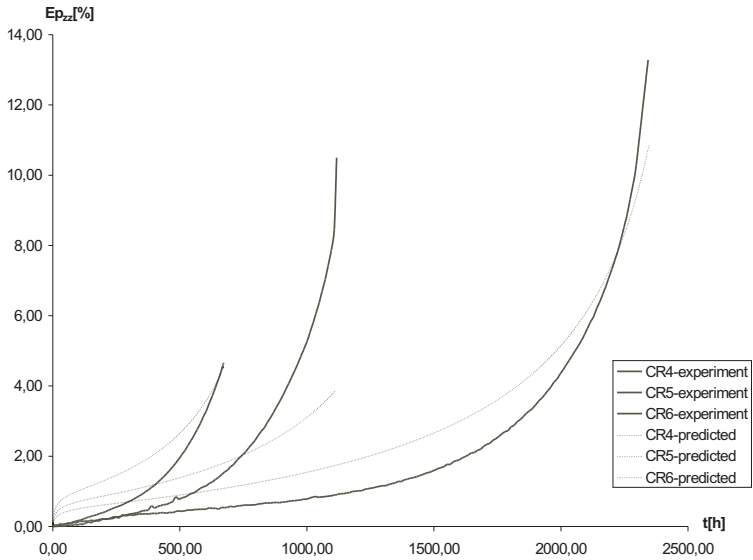

Figure 7.8: Creep loading near [111] orientation. The specimens are subject to constant stresses of $140\text{MPa}(CR4)$, $155\text{MPa}(CR5)$ and $128\text{MPa}(CR6)$, respectively.

8 Use of a continuum damage model based on energy equivalence to predict the response of a single-crystal superalloy

P. Grammenoudis, D. Reckwerth, Ch. Tsakmakis

**Journal of Engineering Materials and Technology,
in press**

Use of a continuum damage model based on energy equivalence to predict the response of a single-crystal superalloy

P. Grammenoudis^{*}, D. Reckwerth[°], Ch. Tsakmakis^{*}

^{*}Darmstadt University of Technology, Institute of Continuum Mechanics,
Hochschulstraße 1, 64289 Darmstadt, Germany

[°]Continental Teves AG & Co. oHG, Guerickestr. 7, 60488 Frankfurt am Main, Germany

Abstract

Anisotropic viscoplasticity coupled with anisotropic damage has been modeled in previous works by using the energy equivalence principle appropriately adjusted. Isotropic and kinematic hardening are present in the viscoplastic part of the model and the evolution equations for the hardening variables incorporate both, static and dynamic recovery terms. The main difference to other approaches consists in the formulation of the energy equivalence principle for the plastic stress power and the rate of hardening energy stored in the material. As a practical consequence a yield function has been established, which depends, besides effective stress variables, on specific functions of damage. The present paper addresses the capabilities of the model in predicting responses of deformation processes with complex specimen geometry. In particular, multiple notched circular specimens and plates with multiple holes under cyclic loading conditions are considered. Comparison of predicted responses with experimental results confirm the convenience of the proposed theory for describing anisotropic damage effects.

8.1 Introduction

Continuum damage models rely upon the assumption that the unknown response functions for the real damaged material may be established from that ones for an undamaged fictitious material. The response functions for the latter, which are supposed to be known, have to be expressed, in some way, in terms of so-called effective stress and effective strain variables. Cordebois and Sidoroff [29] discussed the energy equivalence principle for the case of pure elastic mechanical behaviour. Extensions to elastic-plastic materials were proposed e.g. by Chow and Lu [24, 111] as well as Saanouni, Forster and Hatira [57]. Only isotropic hardening is considered in Chow and Lu [24] and an equivalence for the incremental plastic work is postulated. According to the assumptions made, the yield function for the real material is known and the effective accumulated plastic strain is gained from the principle. The latter is used to formulate the isotropic hardening rule for the real material. Both, isotropic and kinematic hardening are assumed to be present in the theory of Saanouni, Forster and Hatira [57]. Equivalence is defined for the free energy functions responsible for elasticity and for the energy stored in the material due to hardening, as well as for the dissipation potentials. The yield function for the real material is identical to that one for the undamaged material but expressed in terms of effective stresses.

A somewhat different energy equivalence approach for modeling damage effects in viscoplasticity has been elaborated in Grammenoudis, Reckwerth and Tsakmakis [76, 77]. In opposite to other continuum damage theories, in this approach the yield function for the real material is generally not assumed to be known or to be established from that one for the undamaged material by expressing the latter in terms of effective stresses only. Besides equivalence of the free energy functions, it is postulated an equivalence for the material functions governing the plastic and the hardening powers. As a result, a family of yield functions for the real material and the evolution equations for the hardening variables are obtained. The resulting constitutive model has been employed in Grammenoudis, Reckwerth and Tsakmakis [77] to calculate stress distributions for a single-crystal superalloy subject to complex axial loading histories. Comparison with experimental data demonstrated the capabilities of the model to predict such loading histories adequately. In the present paper we shall show that the established model enables to predict appropriately real material behaviour of the single-crystal superalloy also for complex specimen geometry and strong inhomogeneous stress distributions. To this end, multiple notched circular specimens and plates with multiple holes under cyclic loading conditions are considered.

8.2 Constitutive model

8.2.1 Fictitious undamaged material

Throughout the paper we concentrate on small deformations and we use the same nomenclature as in Grammenoudis, Reckwerth and Tsakmakis [76, 77]. The undamaged, fictitious material is supposed to be governed by the following system of viscoplastic constitutive equations:

$$\mathbf{E} = \mathbf{E}_e + \mathbf{E}_p \quad , \quad (8.1)$$

$$\tilde{\Psi}(\mathbf{E}_e, \mathbf{Y}, r) = \tilde{\Psi}_e(\mathbf{E}_e) + \tilde{\Psi}_p(\mathbf{Y}, r) \quad , \quad (8.2)$$

$$\tilde{\Psi}_e(\mathbf{E}_e) = \frac{1}{2\rho} \mathbf{E}_e \cdot \mathbf{C}[\mathbf{E}_e] \quad , \quad (8.3)$$

$$\mathbf{T} = \rho \frac{\partial \tilde{\Psi}_e}{\partial \mathbf{E}_e} = \mathbf{C}[\mathbf{E}_e] \quad , \quad (8.4)$$

$$\mathcal{C}_{ijkl} = \mathcal{C}_{jikl} = \mathcal{C}_{klij} \quad , \quad (8.5)$$

$$\tilde{\Psi}_p(\mathbf{Y}, r) = \tilde{\Psi}_p^{kin}(\mathbf{Y}) + \tilde{\Psi}_p^{is}(r) \quad , \quad (8.6)$$

$$\tilde{\Psi}_p^{kin}(\mathbf{Y}) = \frac{1}{2\rho} \mathbf{Y} \cdot \mathcal{N}[\mathbf{Y}] \quad , \quad (8.7)$$

$$\tilde{\Psi}_p^{is}(r) = \frac{\gamma}{2\rho} r^2 \quad , \quad (8.8)$$

$$\boldsymbol{\xi} := \rho \frac{\partial \tilde{\Psi}_p^{kin}}{\partial \mathbf{Y}} = \mathcal{N}[\mathbf{Y}] \quad , \quad (8.9)$$

$$R := \rho \frac{\partial \tilde{\Psi}_p^{is}}{\partial r} = \gamma r \quad , \quad (8.10)$$

$$r(t=0) = 0 \quad , \quad R(t=0) = 0 \quad , \quad (8.11)$$

$$\tilde{F}(\mathbf{T}, \boldsymbol{\xi}, R) := \tilde{f}(\mathbf{T} - \boldsymbol{\xi}, R) - k_0 \quad , \quad (8.12)$$

$$\tilde{f}(\mathbf{T} - \boldsymbol{\xi}, R) := \sqrt{\frac{3}{2}(\mathbf{T} - \boldsymbol{\xi})^D \cdot \mathcal{K}[(\mathbf{T} - \boldsymbol{\xi})^D]} - R \equiv \sqrt{\frac{3}{2}(\mathbf{T} - \boldsymbol{\xi}) \cdot \mathcal{K}[\mathbf{T} - \boldsymbol{\xi}]} - R \quad , \quad (8.13)$$

$$\dot{s} = \sqrt{\frac{2}{3} \dot{\mathbf{E}}_p \cdot \dot{\mathbf{E}}_p} := \frac{\langle \tilde{F}(\mathbf{T}, \boldsymbol{\xi}, R) \rangle^{m^*}}{\eta} \quad , \quad (8.14)$$

$$\dot{\mathbf{E}}_p = \tilde{\mathbf{f}}_p(\dot{s}, \mathbf{T}, \boldsymbol{\xi}, R) := \frac{\dot{s} \partial \tilde{F}}{\zeta \partial \mathbf{T}} = \frac{3\dot{s} \mathcal{K}[\mathbf{T} - \boldsymbol{\xi}]}{2\zeta \tilde{f} + R} \quad , \quad (8.15)$$

$$\zeta = \tilde{f}_\zeta(\mathbf{T} - \boldsymbol{\xi}, R) := \sqrt{\frac{2}{3} \frac{\partial \tilde{f}}{\partial(\mathbf{T} - \boldsymbol{\xi})} \cdot \frac{\partial \tilde{f}}{\partial(\mathbf{T} - \boldsymbol{\xi})}} = \frac{1}{\tilde{f} + R} \sqrt{\frac{3}{2} \mathcal{K}[\mathbf{T} - \boldsymbol{\xi}] \cdot \mathcal{K}[\mathbf{T} - \boldsymbol{\xi}]} \quad , \quad (8.16)$$

$$\dot{\mathbf{Y}} = \tilde{\mathbf{f}}_Y(\dot{s}, \mathbf{T}, \boldsymbol{\xi}, R) = \dot{\mathbf{E}}_p - \frac{\dot{s}}{\zeta} \mathcal{Q}[\boldsymbol{\xi}] - \|\boldsymbol{\xi}\|^w \mathcal{B}[\boldsymbol{\xi}] \quad , \quad (8.17)$$

$$\dot{r} = \tilde{f}_r(\dot{s}, \mathbf{T}, \boldsymbol{\xi}, R) = (1 - \beta R) \frac{\dot{s}}{\zeta} - \pi R^\omega \quad , \quad (8.18)$$

$$\text{If } \mathcal{L} \in \{\mathcal{K}, \mathcal{N}, \mathcal{Q}, \mathcal{B}\} \text{ then } \mathcal{L}_{ijkl} = \mathcal{L}_{jikl} = \mathcal{L}_{klij} \Rightarrow \mathcal{L} = \mathcal{L}^T \quad , \quad (8.19)$$

$$\mathcal{L}_{ijkl} = 0 \Leftrightarrow \mathcal{L}[\mathbf{1}] = \mathbf{0} \quad , \quad (8.20)$$

$$\tilde{w}_p(\dot{s}, \mathbf{T}, \boldsymbol{\xi}, R) := \mathbf{T} \cdot \tilde{\mathbf{f}}_p(\dot{s}, \mathbf{T}, \boldsymbol{\xi}, R) \quad , \quad (8.21)$$

$$\tilde{w}_{kin}(\dot{s}, \mathbf{T}, \boldsymbol{\xi}, R) := \boldsymbol{\xi} \cdot \tilde{\mathbf{f}}_Y(\dot{s}, \mathbf{T}, \boldsymbol{\xi}, R) \quad , \quad (8.22)$$

$$\tilde{w}_{is}(\dot{s}, \mathbf{T}, \boldsymbol{\xi}, R) := R \tilde{f}_r(\dot{s}, \mathbf{T}, \boldsymbol{\xi}, R) \quad . \quad (8.23)$$

Equation (8.1) is the decomposition of the (linearized) strain tensor \mathbf{E} into elastic and plastic parts and $\tilde{\Psi}$ is the specific free energy function with $\tilde{\Psi}_e$, $\tilde{\Psi}_p^{kin}$ and $\tilde{\Psi}_p^{is}$ being responsible for effects due to elasticity, kinematic and isotropic hardening, respectively. Further, \mathbf{T} denotes the Cauchy stress tensor, ρ is the mass density and the components of the forth-order tensors \mathcal{C} , \mathcal{N} , \mathcal{K} , \mathcal{Q} , \mathcal{B} , as well as w , π , ω , represent material parameters. According to Equation (8.14), plastic flow occurs whenever a positive overstress \tilde{F} exists, with m^* , η , k_0 being material parameters. The yield surface $\tilde{f} = k_0$ represents essentially a so-called quadratic criterion, anisotropy being induced by the tensor \mathcal{K} . Such quadratic criteria have been used for example by [130, 132, 133]. As reported in [131], quadratic yield criteria seem to be inconvenient to describe accurately some torsional loadings of single crystals with cubic symmetry, like the single-crystal superalloy considered in the paper. But generally, according to [130], the material responses predicted in several tests were very encouraging, so that we decided to develop our energy equivalence firstly with reference to a quadratic yield criterion, in order to get formulations as simple as possible. Finally, \mathbf{Y} , r are strain like state variables reflecting effects due to isotropic and kinematic hardening, the conjugate stresses being $\boldsymbol{\xi}$, R , respectively. Corresponding evolution equations, including static and dynamic recovery terms, are formulated through Equations (8.17) and (8.18). Equations (8.21)–(8.23) describe the powers of plastic work, kinematic and isotropic hardening work, respectively, as functions of state variables. It is emphasized that the viscoplasticity theory summarized above is similar to that one advocated by Chaboche and coworkers (see e.g. [130, 132, 133]), some differences consisting essentially only in the equation for \dot{s} and the equations for isotropic and kinematic hardening.

8.2.2 Modeling of damage effects

Following concepts of continuum damage mechanics, damage effects are captured by amplifying the set of variables with the symmetric second-order damage tensor \mathbf{D} . Then, the real (damaged) material response is assumed to be characterized by the following constitutive relations:

$$\mathbf{E} = \mathbf{E}_e + \mathbf{E}_p \quad , \quad (8.24)$$

$$\Psi = \bar{\Psi}(\mathbf{E}_e, \mathbf{Y}, r, \mathbf{D}) = \Psi_e + \Psi_p \quad , \quad (8.25)$$

$$\Psi_p = \Psi_p^{kin} + \Psi_p^{is} \quad , \quad (8.26)$$

$$\Psi_e = \bar{\Psi}_e(\mathbf{E}_e, \mathbf{D}) \quad , \quad (8.27)$$

$$\Psi_p^{kin} = \bar{\Psi}_p^{kin}(\mathbf{Y}, \mathbf{D}) \quad , \quad (8.28)$$

$$\Psi_p^{is} = \bar{\Psi}_p^{is}(r, \mathbf{D}) \quad , \quad (8.29)$$

$$\mathbf{T} = \rho \frac{\partial \bar{\Psi}_e}{\partial \mathbf{E}_e} \quad , \quad (8.30)$$

$$\boldsymbol{\xi} := \rho \frac{\partial \bar{\Psi}_p^{kin}}{\partial \mathbf{Y}} \quad , \quad (8.31)$$

$$R := \rho \frac{\partial \bar{\Psi}_p^{is}}{\partial r} \quad , \quad (8.32)$$

$$\boldsymbol{\Omega} := -\rho \frac{\partial \bar{\Psi}}{\partial \mathbf{D}} \quad , \quad (8.33)$$

$$F(t) = \bar{F}(\mathbf{T}, \boldsymbol{\xi}, R, \mathbf{D}) = \bar{f}(\mathbf{T} - \boldsymbol{\xi}, R, \mathbf{D}) - k_0 \geq 0 \quad , \quad (8.34)$$

$$\dot{\mathbf{E}}_p = \bar{\mathbf{f}}_p(\dot{s}, \mathbf{T}, \boldsymbol{\xi}, R, \mathbf{D}) := \frac{\dot{s}}{\zeta} \frac{\partial \bar{F}}{\partial \mathbf{T}} \quad , \quad (8.35)$$

$$\dot{s} = \sqrt{\frac{2}{3} \dot{\mathbf{E}}_p \cdot \dot{\mathbf{E}}_p} := \frac{\langle \bar{F}(\mathbf{T}, \boldsymbol{\xi}, R, \mathbf{D}) \rangle^{m^*}}{\eta} \quad , \quad (8.36)$$

$$\zeta = \bar{f}_\zeta(\mathbf{T} - \boldsymbol{\xi}, R, \mathbf{D}) := \sqrt{\frac{2}{3} \frac{\partial \bar{f}}{\partial (\mathbf{T} - \boldsymbol{\xi})} \cdot \frac{\partial \bar{f}}{\partial (\mathbf{T} - \boldsymbol{\xi})}} \quad , \quad (8.37)$$

$$\dot{\mathbf{Y}} = \bar{\mathbf{f}}_Y(\dot{s}, \mathbf{T}, \boldsymbol{\xi}, R, \mathbf{D}) \quad , \quad (8.38)$$

$$\dot{r} = \bar{f}_r(\dot{s}, \mathbf{T}, \boldsymbol{\xi}, R, \mathbf{D}) \quad , \quad (8.39)$$

$$\bar{w}_p(\dot{s}, \mathbf{T}, \boldsymbol{\xi}, R, \mathbf{D}) := \mathbf{T} \cdot \bar{\mathbf{f}}_p(\dot{s}, \mathbf{T}, \boldsymbol{\xi}, R, \mathbf{D}) \quad , \quad (8.40)$$

$$\bar{w}_{kin}(\dot{s}, \mathbf{T}, \boldsymbol{\xi}, R, \mathbf{D}) := \boldsymbol{\xi} \cdot \bar{\mathbf{f}}_Y(\dot{s}, \mathbf{T}, \boldsymbol{\xi}, R, \mathbf{D}) \quad , \quad (8.41)$$

$$\bar{w}_{is}(\dot{s}, \mathbf{T}, \boldsymbol{\xi}, R, \mathbf{D}) := R \bar{f}_r(\dot{s}, \mathbf{T}, \boldsymbol{\xi}, R, \mathbf{D}) \quad . \quad (8.42)$$

In these equations, the functions $\bar{\Psi}$, \bar{f} , $\bar{\mathbf{f}}_Y$ and \bar{f}_r are unknown and have to be established from the functions $\tilde{\Psi}$, \tilde{f} , $\tilde{\mathbf{f}}_Y$ and \tilde{f}_r by postulating an appropriate version of energy equivalence. According to Grammenoudis, Reckwerth and Tsakmakis [76, 77], this may read as follows:

$$\mathbf{T}^{ef} := \mathcal{M}^{-1}[\mathbf{T}] = \rho \frac{\partial \tilde{\Psi}_e(\mathbf{E}_e^{ef})}{\partial \mathbf{E}_e^{ef}} \quad , \quad (8.43)$$

$$\mathbf{E}_e^{ef} := \mathcal{H}[\mathbf{E}_e] \quad , \quad (8.44)$$

$$\boldsymbol{\xi}^{ef} := \mathcal{M}^{-1}[\boldsymbol{\xi}] = \rho \frac{\partial \tilde{\Psi}_p^{kin}(\mathbf{Y}^{ef})}{\partial \mathbf{Y}^{ef}} \quad , \quad (8.45)$$

$$\mathbf{Y}^{ef} := \mathcal{H}[\mathbf{Y}] \quad , \quad (8.46)$$

$$R^{ef} := \frac{R}{m} = \rho \frac{\partial \tilde{\Psi}_p^{is}(r^{ef})}{\partial r^{ef}} \quad , \quad (8.47)$$

$$r^{ef} := hr \quad , \quad (8.48)$$

$$\zeta^{ef} = \tilde{f}_\zeta(\mathbf{T}^{ef} - \boldsymbol{\xi}^{ef}, R^{ef}) \quad , \quad (8.49)$$

$$\frac{\dot{s}^{ef}}{\zeta^{ef}} = g \frac{\dot{s}}{\zeta} \chi \quad , \quad (8.50)$$

$$\mathcal{M} = \mathcal{M}(\mathbf{D}) \quad , \quad \mathcal{H} = \mathcal{H}(\mathbf{D}) \quad , \quad (8.51)$$

$$m = m(\mathbf{D}) \quad , \quad h = h(\mathbf{D}) \quad , \quad (8.52)$$

$$g = g(\mathbf{D}) \quad , \quad \chi = \chi(\mathbf{D}) \quad , \quad (8.53)$$

$$\bar{\Psi}_e(\mathbf{E}_e, \mathbf{D}) = \tilde{\Psi}_e(\mathbf{E}_e^{ef}) \quad , \quad (8.54)$$

$$\bar{\Psi}_p^{(kin)}(\mathbf{Y}, \mathbf{D}) = \tilde{\Psi}_p^{kin}(\mathbf{Y}^{ef}) \quad , \quad (8.55)$$

$$\bar{\Psi}_p^{(is)}(r, \mathbf{D}) = \tilde{\Psi}_p^{is}(r^{ef}) \quad , \quad (8.56)$$

$$\bar{w}_p(\dot{s}, \mathbf{T}, \boldsymbol{\xi}, R, \mathbf{D}) = \frac{1}{\chi} \tilde{w}_p(\dot{s}^{ef}, \mathbf{T}^{ef}, \boldsymbol{\xi}^{ef}, R^{ef}) \quad , \quad (8.57)$$

$$\bar{w}_{kin}(\dot{s}, \mathbf{T}, \boldsymbol{\xi}, R, \mathbf{D}) = \frac{1}{\chi} \tilde{w}_{kin}(\dot{s}^{ef}, \mathbf{T}^{ef}, \boldsymbol{\xi}^{ef}, R^{ef}) \quad , \quad (8.58)$$

$$\bar{w}_{is}(\dot{s}, \mathbf{T}, \boldsymbol{\xi}, R, \mathbf{D}) = \frac{1}{\chi} \tilde{w}_{is}(\dot{s}^{ef}, \mathbf{T}^{ef}, \boldsymbol{\xi}^{ef}, R^{ef}) \quad , \quad (8.59)$$

where \mathcal{M} , m , g and χ are given functions of \mathbf{D} . As shown in Grammenoudis, Reckwerth and Tsakmakis [77], it turns out that the forth-order damage effect tensor \mathcal{H} and the scalar valued damage effect function h satisfy the relations

$$\mathcal{H}(\mathbf{D}) = \mathcal{M}^T(\mathbf{D}) \quad , \quad h(\mathbf{D}) = m(\mathbf{D}) \quad , \quad (8.60)$$

the yield function \bar{f} has the form

$$\bar{f}(\mathbf{T} - \boldsymbol{\xi}, R, \mathbf{D}) = g(\mathbf{D}) \tilde{f}(\mathbf{T}^{ef} - \boldsymbol{\xi}^{ef}, R^{ef}) = g \sqrt{\frac{3}{2}(\mathbf{T} - \boldsymbol{\xi}) \cdot \mathcal{M}^{T-1} \mathcal{K} \mathcal{M}^{-1} [\mathbf{T} - \boldsymbol{\xi}]} - \frac{gR}{m} \quad (8.61)$$

and the functions $\bar{\mathbf{f}}_{\mathbf{Y}}$ and \bar{f}_r , governing the hardening laws for the real material, become

$$\begin{aligned} \bar{\mathbf{f}}_{\mathbf{Y}}(\dot{s}, \mathbf{T}, \boldsymbol{\xi}, R, \mathbf{D}) &= \frac{1}{\chi} \mathcal{M}^{T-1} [\tilde{\mathbf{f}}_{\mathbf{Y}}(\dot{s}^{ef}, \mathbf{T}^{ef}, \boldsymbol{\xi}^{ef}, R^{ef})] \\ &= \dot{\mathbf{E}}_p - g \frac{\dot{s}}{\zeta} \mathcal{M}^{T-1} \mathcal{Q} \mathcal{M}^{-1} [\boldsymbol{\xi}] - \frac{1}{\chi} \|\mathcal{M}^{-1} [\boldsymbol{\xi}]\|^w \mathcal{M}^{T-1} \mathcal{B} \mathcal{M}^{-1} [\boldsymbol{\xi}] \quad , \end{aligned} \quad (8.62)$$

$$\bar{f}_r(\dot{s}, \mathbf{T}, \boldsymbol{\xi}, R, \mathbf{D}) = \frac{1}{\chi m} \tilde{f}_r(\dot{s}^{ef}, \mathbf{T}^{ef}, \boldsymbol{\xi}^{ef}, R^{ef}) = \left(1 - \beta \frac{R}{m}\right) \frac{g}{m} \frac{\dot{s}}{\zeta} - \frac{\pi}{\chi m} \left(\frac{R}{m}\right)^\omega \quad . \quad (8.63)$$

Specific forms for the functions $\mathcal{M}(\mathbf{D})$, $m(\mathbf{D})$, $g(\mathbf{D})$ and $\chi(\mathbf{D})$, assumed in Grammenoudis, Reckwerth and Tsakmakis [77], are (cf. also [29])

$$\mathcal{M}(\mathbf{D})[\mathbf{X}] = (\mathbf{1} - \mathbf{D})\mathbf{X}(\mathbf{1} - \mathbf{D}) \quad , \quad (8.64)$$

$$m(\mathbf{D}) = \frac{1}{g(\mathbf{D})} = \{\det(\mathbf{1} - \mathbf{D})\}^{\frac{2}{3}} \quad , \quad (8.65)$$

$$\chi = (\det(\mathbf{1} - \mathbf{D}))^{-l} \quad , \quad (8.66)$$

with l being material parameter.

To accomplish the system of constitutive equations, the damage law

$$\dot{\mathbf{D}} = \frac{\mathcal{Q}_c[\boldsymbol{\Omega}]}{\sqrt{\boldsymbol{\Omega} \cdot \mathcal{Q}_c[\boldsymbol{\Omega}]}} \frac{\langle \chi_c(\mathbf{T}) \rangle^{r_c}}{A_c} \{\det(\mathbf{1} - \mathbf{D})\}^{-k_c} \quad (8.67)$$

has been assumed in Grammenoudis, Reckwerth and Tsakmakis [77], where χ_c is essentially a damage criterion function proposed by Hayhurst [83],

$$\chi_c(\mathbf{T}) := \alpha_c T_M + \beta_c (\text{tr} \mathbf{T}) + (1 - \alpha_c - \beta_c) \sqrt{\frac{3}{2} \mathbf{T} \cdot \mathcal{M}_c[\mathbf{T}]} \quad , \quad (8.68)$$

T_M denotes the maximum principal tensile stress, \mathcal{Q}_c , \mathcal{M}_c are fourth-order tensors with components representing material parameters, and α_c , β_c , A_c , r_c , k_c are material parameters.

Specific representations for cubic symmetry and corresponding material parameters for a Ni-base single-crystal superalloy, tested at constant temperature of 1050°C, have been given in Grammenoudis, Reckwerth and Tsakmakis [77]. The material parameters are not determined by professional optimization algorithms. Application of such methods is very expensive (see e.g. [89]) and represents the goal of current investigations beyond of the scope of our study.

In the remainder of the paper we shall discuss the capabilities of the presented viscoplasticity theory coupled with damage to predict the response of multiple notched circular specimens and plates with multiple holes under cyclic loading conditions. All calculations are performed by using the finite element code ABAQUS, in which the constitutive theory has been implemented.

8.3 Examples

Predicted responses for a Ni-base single-crystal superalloy, called CSMX-4, and corresponding experimental results are discussed in following subsections. Cubic symmetry is assumed to apply and the material parameters used in the simulations are the same as in [77].

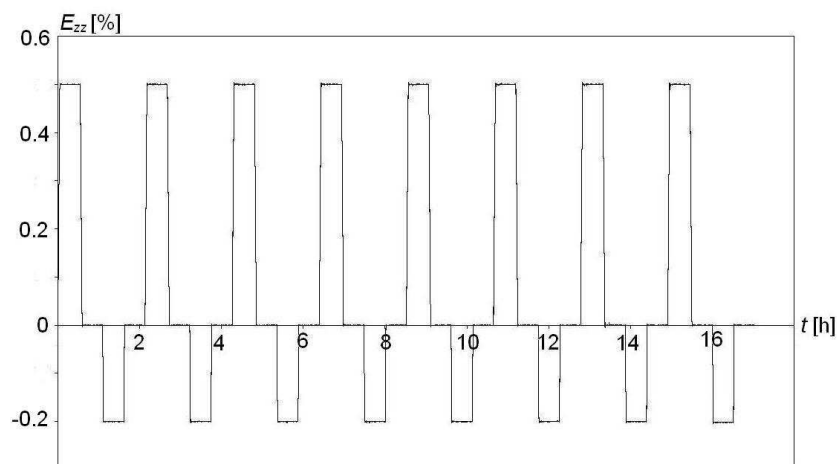

Figure 8.1: Given global strain history over time.

Global axial tension and compression loading conditions with holding times have been applied. The loading history for all experiments is displayed in Figure 8.1, where z signifies the loading axis. The strain rate amounts $0.0018 \frac{1}{min}$ while all relaxation times are equal to 30 minutes. In the considered

numerical examples the loading direction coincides with the axis of the used specimen in the experiment. This direction with respect to crystallographic axes is indicated by means of angles φ_1 , φ_2 (see Figure 8.2).

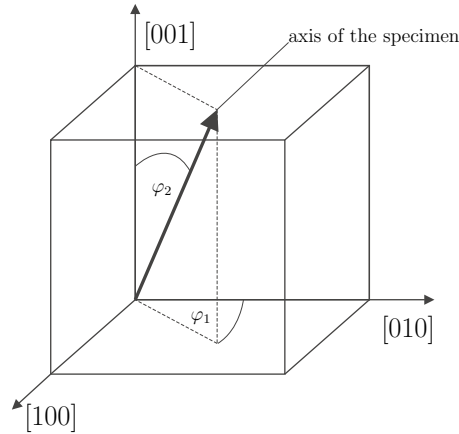

Figure 8.2: Axis of the specimen and crystallographic axes.

8.3.1 Multiple notched circular specimen under cyclic loading conditions



Figure 8.3: Cylindrical multiple notched tensile specimen used in the experiments.

In the first example we consider a cylindrical multiple notched tensile specimen. The specimen used in the experiments is shown in Figure 8.3. The finite element mesh is given in Figure 8.4 and consists of 1248 eight-node hexahedron volume elements and 1613 knots. Some predicted responses and experimental results are displayed in Figures 8.5 and 8.6. The angles φ_1 , φ_2 between, respectively, the loading axes and the [010] and [001] axes are $\varphi_1 = 5.6^\circ$ and $\varphi_2 = 14.9^\circ$.

Figure 8.5 displays the global force acting on the specimen as a function of global strain for multiple notched tensile specimen. The time-global force distribution to realize the strain history is given in Figure 8.6. In spite of the fact that the material parameters are not identified on the basis of some professional optimization algorithms, the predicted model responses in Figure 8.5 and 8.6 confirm the capabilities of the model to describe the experimental results without significant discrepancies.

In order to gain an impression about the evolution and the distribution of the damage in the specimen, the behavior of the damage variable, and in particular the zz -component of \mathbf{D} is considered. Figure 8.7 shows the distribution of the values of the chosen component of the damage variable within the specimen after the eight load cycles. It can be recognized that the damage distribution focuses on the notched areas.

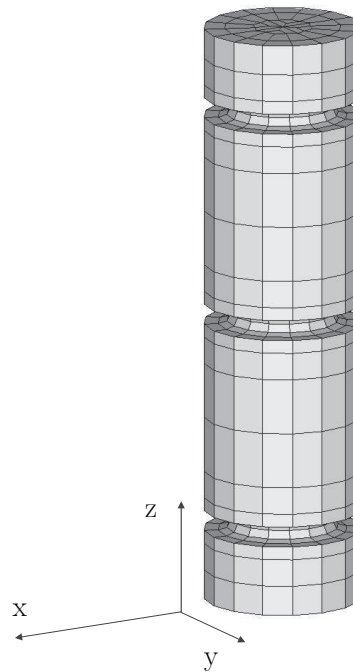

Figure 8.4: Finite element mesh of the cylindrical multiple notched tensile specimen used in the calculations.

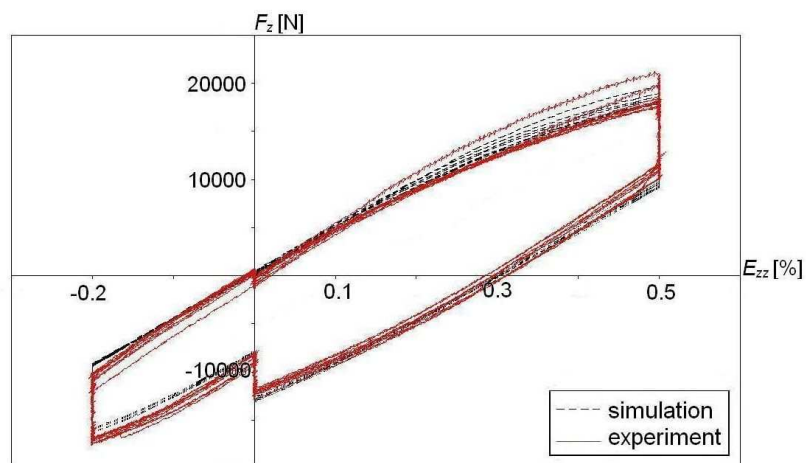

Figure 8.5: Global force acting on the specimen (as function of global strain) to realize the strain history.

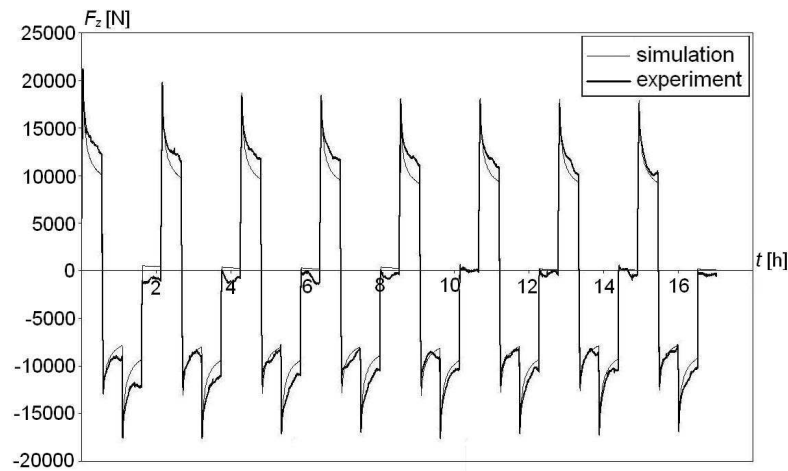

Figure 8.6: Global force acting on the specimen (as function of time) to realize the strain history.

In Figures 8.8–8.10 these areas are represented more precisely. The figures illustrate the circumferential distribution of the zz -component of the damage tensor \mathbf{D} , with $r = 3.35\text{mm}$ being the radius in the plane through the notch root. As can be seen (see also Figure 8.7) that there exists two points of maximum damage lying in the upper and in the lower plane at $z = 34.5\text{mm}$ and $z = 5.5\text{mm}$. Additionally, if we concentrate ourselves in the time evolution damage at these points, then we see that the damage distributions for both points exhibit nearly identical graphs as shown in Figure 8.11.

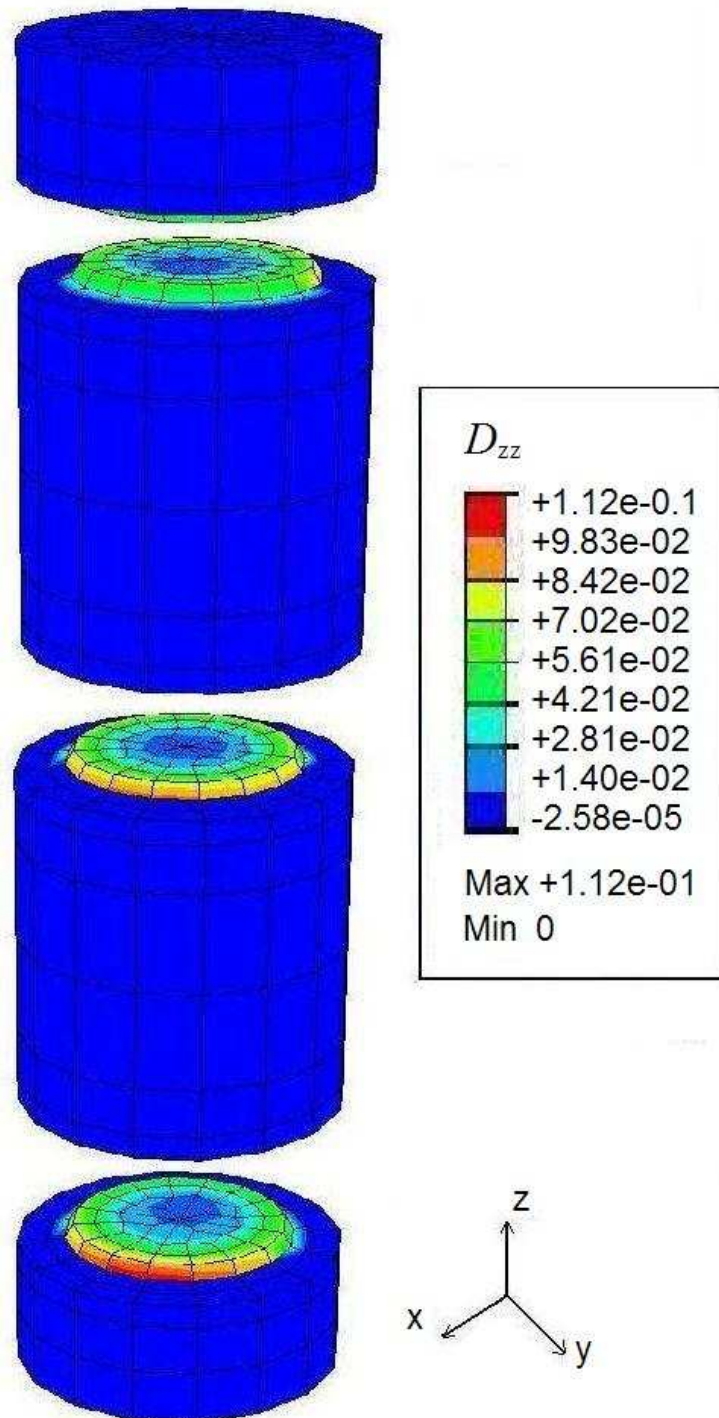

Figure 8.7: Distribution of D_{zz} within the specimen after the eight load cycles.

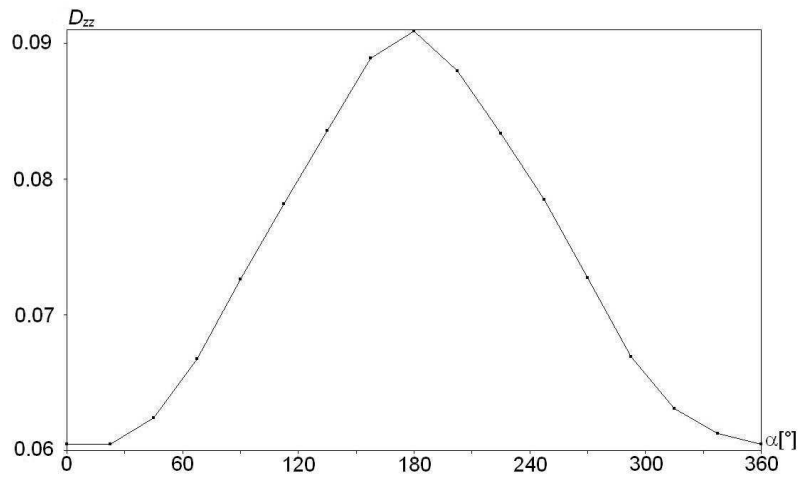

Figure 8.8: Circumferential distribution of D_{zz} at $z = 34.5\text{mm}$ and $r = 3.35\text{mm}$.

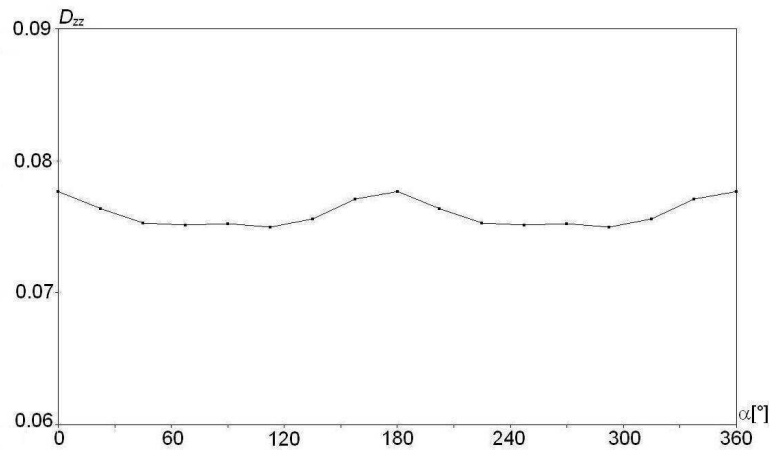

Figure 8.9: Circumferential distribution of D_{zz} at $z = 20\text{mm}$ and $r = 3.35\text{mm}$.

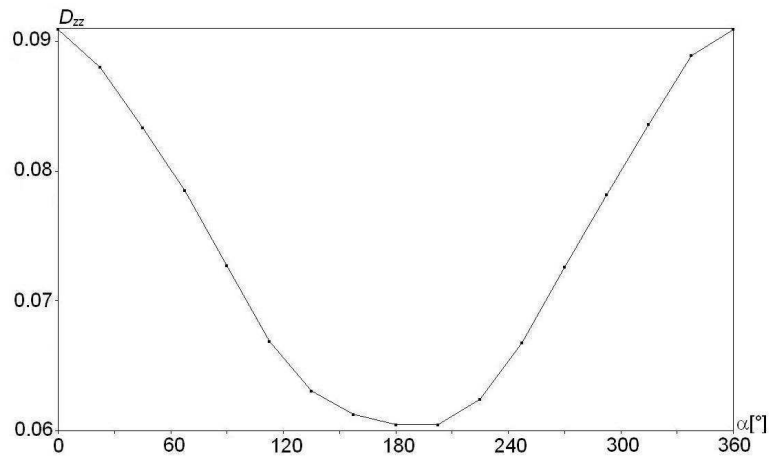

Figure 8.10: Circumferential distribution of D_{zz} at $z = 5.5\text{mm}$ and $r = 3.35\text{mm}$.

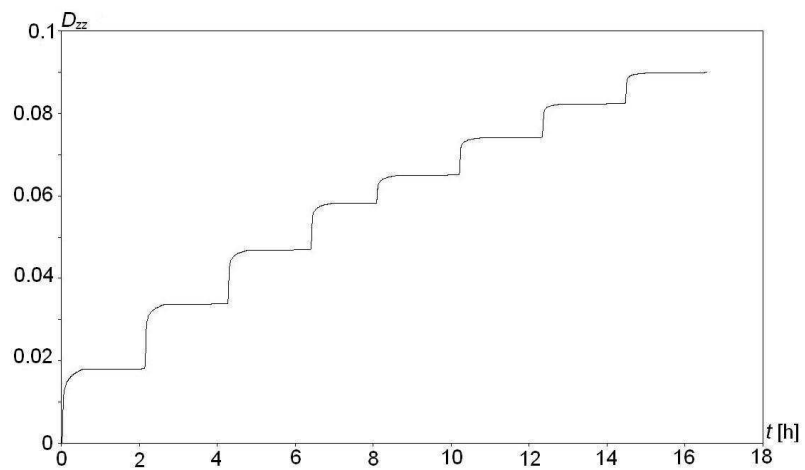

Figure 8.11: Distribution of D_{zz} at $\{x = -3.35, y = 0, z = 5.5\}$ and $\{x = 3.35, y = 0, z = 34.5\}$ as a function of time.

8.3.2 Plate with multiple holes under cyclic loading conditions



Figure 8.12: Plate with multiple holes used in the experiments.

Figure 8.12 illustrate the specimen used in the second example. It represents a plate with wholes and the used finite element mesh is shown in Figure 8.13. This mesh consists of 1140 eight-node hexahedron volume elements and 1944 knots. Experimental results and model predictions for the strain history of Figure 8.1 are displayed in Figures 8.14 and 8.15. The angles φ_1 , φ_2 between, respectively, the loading axes and the [010] and [001] axes are $\varphi_1 = 21.5^\circ$ and $\varphi_2 = 14.2^\circ$.

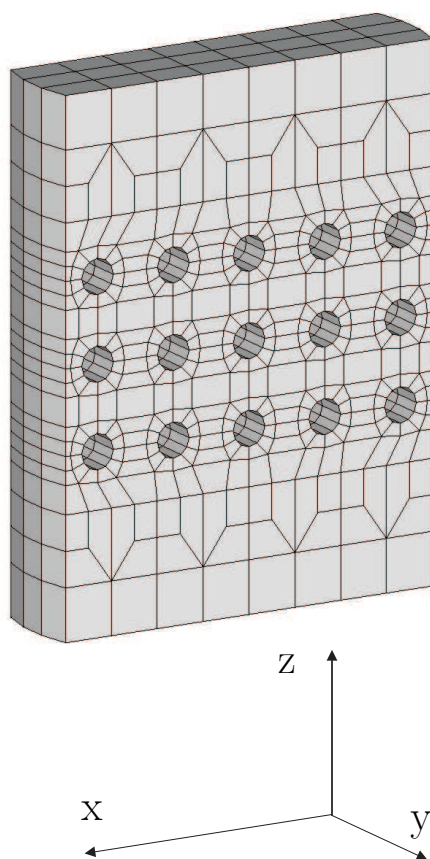

Figure 8.13: Finite element mesh of the plate with multiple holes used in the calculations.

The global force-global strain distribution is given in Figure 8.14, while Figure 8.15 illustrates the global force acting on the specimen as a function of time. Once more, the predicted model responses are in good agreement with the experimental data.

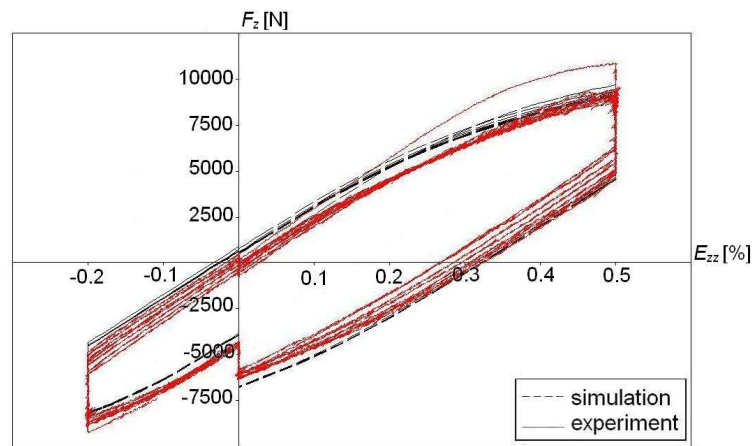

Figure 8.14: Global force acting on the specimen (as function of global strain) to realize the strain history.

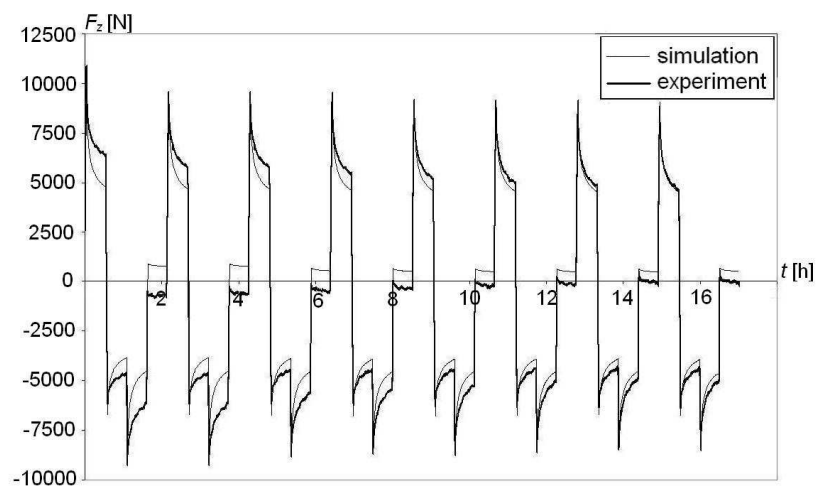

Figure 8.15: Global force acting on the specimen (as function of time) to realize the strain history.

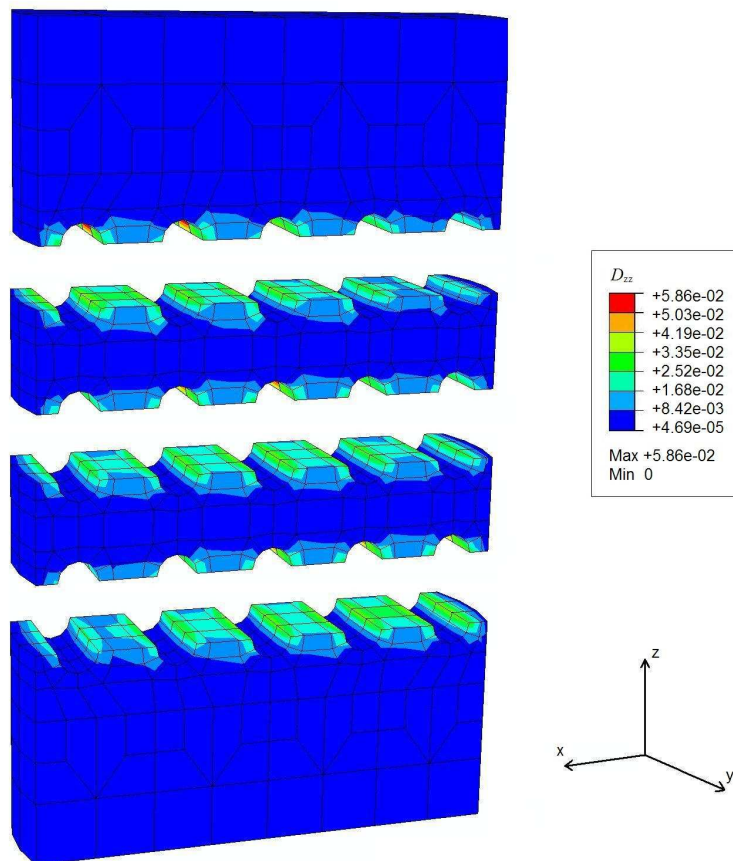

Figure 8.16: Distribution of D_{zz} within the specimen after the eight load cycles.

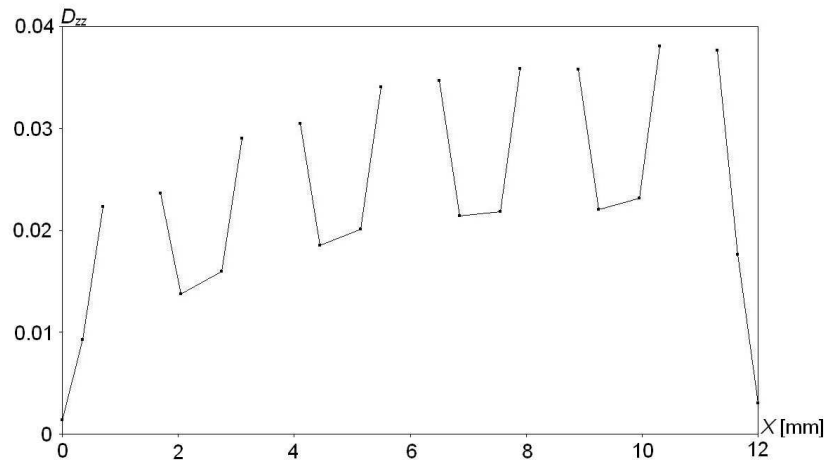

Figure 8.17: Distribution of D_{zz} at $z = 9.9\text{ mm}$ and $y = 1\text{ mm}$ as a function of x .

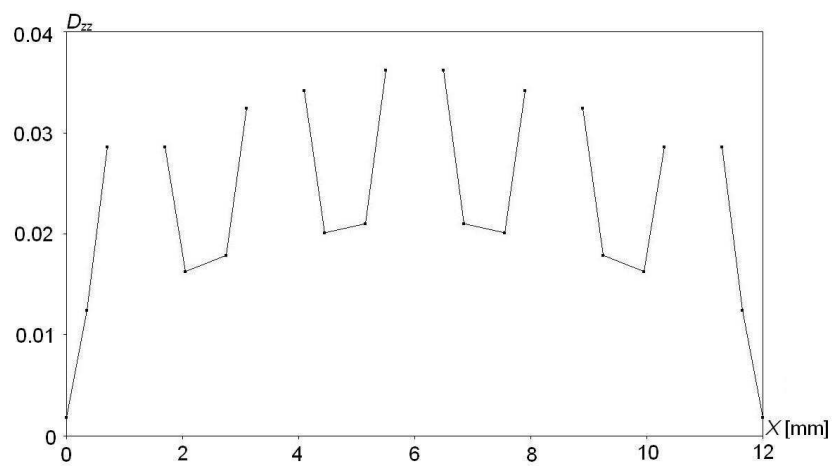

Figure 8.18: Distribution of D_{zz} at $z = 7.5\text{ mm}$ and $y = 1.5\text{ mm}$ as a function of x .

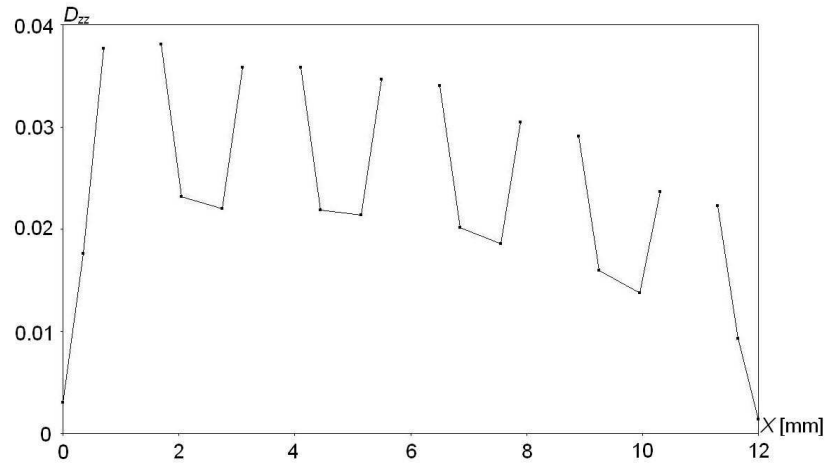

Figure 8.19: Distribution of D_{zz} at $z = 5.1mm$ and $y = 2mm$ as a function of x .

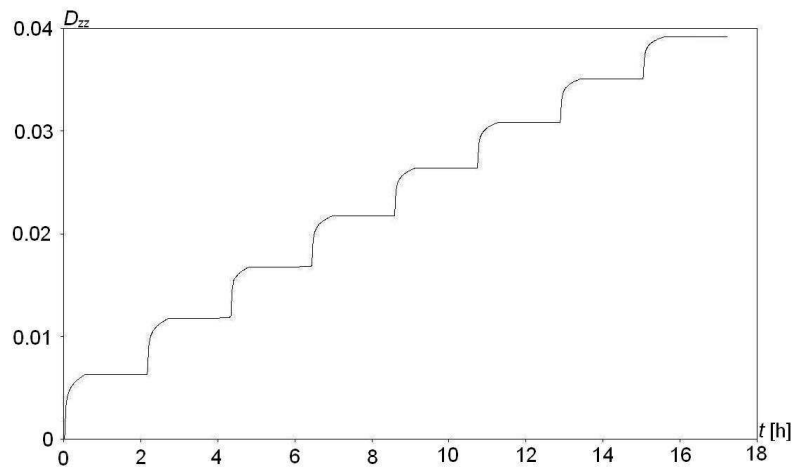

Figure 8.20: Distribution of D_{zz} at $\{x = 10.3, y = 1, z = 9.9\}$ and $\{x = 1.75, y = 2, z = 5.1\}$ as a function of time.

Again, the zz -component of the damage tensor \mathbf{D} is considered in more detail in order to obtain an impression about the evolution and the distribution of the damage within the specimen. After eight load cycles this distribution is shown in Figure 8.16. As can be seen, the damage distribution focuses around every hole. In Figures 8.17–8.19 cuts are considered which are perpendicular to the loading direction and go through the center of the circles. The graphs illustrate the distribution of the zz -component of the damage tensor \mathbf{D} in three plains at $z = 9.9mm$, $z = 7.5mm$ and $z = 5.1mm$. From these diagrams one may conclude that there exists two points of maximum damage lying in the upper and the in lower plane at $\{x = 10.3mm, y = 1mm, z = 9.9mm\}$ and $\{x = 1.7mm, y = 2mm, z = 5.1mm\}$. In Figure 8.20, the time evolution of the damage at these points is shown. As in the case of the multiple notched specimen, the responses for both points are practically identical.

Acknowledgements

The authors thank Dipl.-Ing. P. Fazeli for providing some finite element calculations.

9 Incompatible deformations – plastic intermediate configuration

P. Grammenoudis, Ch. Tsakmakis

ZAMM – Journal of Applied Mathematics and Mechanics / Zeitschrift für Angewandte Mathematik und Mechanik, 88 (2008) 5, 403–432

Incompatible deformations – plastic intermediate configuration

P. Grammenoudis, Ch. Tsakmakis

**Darmstadt University of Technology, Institute of Continuum Mechanics,
Hochschulstraße 1, 64289 Darmstadt, Germany**

Dedicated to Professor Peter Haupt, on the occasion of his 70th birthday, who made the second author familiar with the notion of the plastic intermediate configuration.

Abstract

There are many approaches in continuum mechanics involving incompatible deformations, one well-known example being the polar decomposition of the deformation gradient tensor. Such deformations have in the past been regarded rather in the context of local configurations. In the present paper, we discuss incompatible deformations among others, also from the point of view of material lines. Related covariant derivatives and spatial differential operators are introduced and investigated. In particular, it is shown that components of curvature tensors, present in many gradient constitutive theories, may be expressed in terms of the difference between different connections for the same manifold. These issues are illustrated with reference to multiplicative decompositions of deformation gradient tensors into elastic and plastic parts. Two classes of model materials are addressed, non-polar and micropolar ones.

9.1 Introduction

In opposite to the deformation gradient tensor, there are deformation tensors, which do not satisfy compatibility conditions. Such deformations, one well-known example being the rotation in the polar decomposition of the deformation gradient tensor, are called incompatible. While most of finite deformation (so-called) local theories rest on the polar decomposition of the deformation gradient tensor, incompatible deformations related to inelasticity have been broadly elaborated in non-local crystal plasticity theories. Such, so-called continuum theories of defects, the investigation of which has been initiated by Kondo, Bilby et al. and Kröner (see e.g. [94, 9, 95]), deal with the torsion of the space as variable (see among others e.g. Le and Stumpf [98, 99], Gurtin [80, 79], Epstein and Maugin [44], Dluzewski [40]). A study of bodies with inhomogeneities from the point of view of local configurations has been given by Noll [129] (see also [155], Sects. 22, 34), who introduced also the term relative gradient, for some spatial differential operators related to local deformations. Le and Stumpf (see e.g. [98, 99]) applied the mathematical and physical framework of Noll's approach to incorporate the multiplicative decomposition of the deformation gradient tensor into elastic and plastic parts in continuum theories of dislocations. There are continuum theories of dislocations fitted in the framework of non-polar materials, and such fitted in the framework of micropolar ones. Micropolar continua exhibit a microstructure,

which suffers rigid body rotations. The references cited above belong to the former class. In the works e.g. of Minagawa [119, 120], Anthony [6], Hehl and Kröner [84], Günther [65] Eringen and Claus [47], and Clayton et al. [26], fundamental concepts concerning micropolar degrees of freedom are addressed.

In the present paper we study spatial derivatives related to incompatible deformations from three points of view, namely with respect to 1) transformed covariant derivatives, 2) local deformations, and 3) material lines. Noll's approach of relative gradient is extended to define general relative covariant derivatives. Curvature tensors, expressible in terms of gradients of deformation (not to be confused with Riemannian curvature tensors), are shown to represent differences of connections rather than connections itself. Illustrations of the geometrical aspects are given for gradient continuum theories based on the multiplicative decomposition of the deformation gradient tensor into elastic and plastic parts. Attention is focussed on non-polar continua, as well as on micropolar ones. From the various kinematic variables available to formulate micropolar theories, we chose the ones adopted in Grammenoudis and Tsakmakis [67], in order to demonstrate essential ideas of the paper.

9.2 Preliminaries

We consider isothermal deformations and write t for the time and \mathbb{R} for the axis of real numbers. An explicit reference to space and time will often be dropped in the paper. Commonly, the same symbol is used to designate a function and the value of that function at a point.

Tensor operations in the paper are referred to Euclidean vector spaces. Let \mathbb{E} be a three-dimensional Euclidean vector space, and $\{\mathbf{e}_i\}$ an orthonormal basis in \mathbb{E} . If nothing others is stated, then all indices have the range of the integers $(1, 2, 3)$, while summation over repeated indices is implied. For the purposes of the paper, it suffices to make use of the notation of classical continuum mechanics, i.e. we shall not distinguish between \mathbb{E} and its dual space. Thus, tensors of arbitrary order on \mathbb{E} will be regarded as multilinear functions on \mathbb{E} . The following relationships are referred to tensors on \mathbb{E} , but otherwise can analogously be extended to so-called two point tensors.

Letters set in boldface designate vectors or second-order tensors, while third-order tensors are denoted by calligraphic bold face letters. In particular, $\mathbf{a} \cdot \mathbf{b}$, and $\mathbf{a} \otimes \mathbf{b}$ denote the inner, and the tensor product of the vectors \mathbf{a} and \mathbf{b} , respectively. For second-order tensors \mathbf{A} and \mathbf{B} , we write $\text{tr} \mathbf{A}$ for the trace, $\det \mathbf{A}$ for the determinant and \mathbf{A}^T for the transpose of \mathbf{A} , while $\mathbf{A} \cdot \mathbf{B} = \text{tr}(\mathbf{A}\mathbf{B}^T)$ is the inner product between \mathbf{A} and \mathbf{B} . Furthermore,

$$\mathbf{1} = \delta_{ij} \mathbf{e}_i \otimes \mathbf{e}_j \quad (9.1)$$

represents the identity tensor of second-order, where $\delta_{ij} = \delta^i_j$ is the Kronecker-delta. Often use is made of notations of the form $a_i = (\mathbf{a})_i$, $A_{ij} = (\mathbf{A})_{ij}$, \dots , for the components of vectors \mathbf{a} , second-order tensors \mathbf{A} , and so on. Also, we use the notation $\mathbf{A}^{T-1} = (\mathbf{A}^{-1})^T$, provided $\det \mathbf{A} \neq 0$.

Let $\mathbf{v} = v_i \mathbf{e}_i$, $\mathbf{w} = w_i \mathbf{e}_i$, $\mathbf{u} = u_i \mathbf{e}_i$, $\mathbf{z} = z_i \mathbf{e}_i$ be vectors, $\mathbf{A} = A_{ij} \mathbf{e}_i \otimes \mathbf{e}_j$, $\mathbf{B} = B_{ij} \mathbf{e}_i \otimes \mathbf{e}_j$, $\mathbf{C} = C_{ij} \mathbf{e}_i \otimes \mathbf{e}_j$ be second-order tensors, and $\mathcal{M} = \mathcal{M}_{ijkl} \mathbf{e}_i \otimes \mathbf{e}_j \otimes \mathbf{e}_k \otimes \mathbf{e}_l$ be third-order tensor. Then,

$$\mathbf{A}\mathbf{v} \equiv \mathbf{A}[\mathbf{v}] = A_{ij} v_j \mathbf{e}_i \quad , \quad (9.2)$$

$$\mathbf{A}[\mathbf{v}, \mathbf{w}] = \mathbf{v} \cdot \mathbf{A}\mathbf{w} = v_i A_{ij} w_j \quad , \quad (9.3)$$

$$\mathbf{A}\mathbf{B} = (A_{ij} \mathbf{e}_i \otimes \mathbf{e}_j) \mathbf{B} = A_{ij} \mathbf{e}_i \otimes \mathbf{B}^T \mathbf{e}_j = A_{ij} B_{jm} \mathbf{e}_i \otimes \mathbf{e}_m \quad , \quad (9.4)$$

$$\mathbf{A}^2 = \mathbf{A}\mathbf{A} = A_{ij}A_{jk} \mathbf{e}_i \otimes \mathbf{e}_k \quad , \quad (9.5)$$

$$\mathcal{M}[\mathbf{v}, \mathbf{w}, \mathbf{u}] = \mathcal{M}_{ijk}(\mathbf{e}_i \cdot \mathbf{v})(\mathbf{e}_j \cdot \mathbf{w})(\mathbf{e}_k \cdot \mathbf{u}) \quad . \quad (9.6)$$

$\mathbf{A}\mathcal{M}$, $\mathcal{M}\mathbf{A}^T$ and $\mathbf{A} \diamond \mathcal{M} \equiv \mathcal{M} \diamond \mathbf{A}^T$ are defined to represent third-order tensors given by

$$\mathbf{A}\mathcal{M} := \mathcal{M}_{ijk}(\mathbf{A}\mathbf{e}_i) \otimes \mathbf{e}_j \otimes \mathbf{e}_k = A_{mi}\mathcal{M}_{ijk}\mathbf{e}_m \otimes \mathbf{e}_j \otimes \mathbf{e}_k \quad , \quad (9.7)$$

$$\mathcal{M}\mathbf{A}^T := \mathcal{M}_{ijk}\mathbf{e}_i \otimes \mathbf{e}_j \otimes (\mathbf{A}\mathbf{e}_k) = \mathcal{M}_{ijk}A_{mk}\mathbf{e}_i \otimes \mathbf{e}_j \otimes \mathbf{e}_m \quad , \quad (9.8)$$

$$\mathbf{A} \diamond \mathcal{M} \equiv \mathcal{M} \diamond \mathbf{A}^T := \mathcal{M}_{ijk}\mathbf{e}_i \otimes (\mathbf{A}\mathbf{e}_j) \otimes \mathbf{e}_k = \mathcal{M}_{ijk}A_{mj}\mathbf{e}_i \otimes \mathbf{e}_m \otimes \mathbf{e}_k \quad . \quad (9.9)$$

If $\mathcal{M} = \mathbf{B} \otimes \mathbf{z}$, then

$$\mathbf{A}\mathcal{M} = \mathbf{A}(\mathbf{B} \otimes \mathbf{z}) = (\mathbf{A}\mathbf{B}) \otimes \mathbf{z} \quad , \quad (9.10)$$

$$\mathcal{M}\mathbf{A}^T = (\mathbf{B} \otimes \mathbf{z})\mathbf{A}^T = \mathbf{B} \otimes (\mathbf{A}\mathbf{z}) \quad , \quad (9.11)$$

$$\mathbf{A} \diamond \mathcal{M} \equiv \mathcal{M} \diamond \mathbf{A}^T = (\mathbf{B}\mathbf{A}^T) \otimes \mathbf{z} \quad , \quad (9.12)$$

and

$$\mathcal{M}[\mathbf{v}, \mathbf{w}, \mathbf{u}] = (\mathbf{B} \otimes \mathbf{z})[\mathbf{v}, \mathbf{w}, \mathbf{u}] = (\mathbf{v} \cdot \mathbf{B}\mathbf{w})(\mathbf{z} \cdot \mathbf{u}) \quad . \quad (9.13)$$

To the second-order tensors \mathbf{A} , \mathbf{B} , \mathbf{C} , a linear operator $\mathcal{L}(\mathbf{A}, \mathbf{B}, \mathbf{C})$ can be assigned, which acts on third-order tensors \mathcal{M} and generates third-order tensors

$$\mathcal{L}(\mathbf{A}, \mathbf{B}, \mathbf{C})[\mathcal{M}] := \mathcal{M}_{ijk}(\mathbf{A}\mathbf{e}_i) \otimes (\mathbf{B}\mathbf{e}_j) \otimes (\mathbf{C}\mathbf{e}_k) \quad . \quad (9.14)$$

In the special case $\mathbf{A} = \mathbf{B} = \mathbf{C}$, we write simply $\mathcal{L}(\mathbf{A})$ instead of $\mathcal{L}(\mathbf{A}, \mathbf{A}, \mathbf{A})$ and get

$$\mathcal{L}(\mathbf{A})[\mathcal{M}] = \mathcal{M}_{ijk}(\mathbf{A}\mathbf{e}_i) \otimes (\mathbf{A}\mathbf{e}_j) \otimes (\mathbf{A}\mathbf{e}_k) \quad . \quad (9.15)$$

9.3 Basic kinematic relations

9.3.1 Reference and actual configuration

Consider a material body \mathcal{B} (macroscopic continuum, or macroscopic material, or overall material body), with elements $\mathcal{X}, \mathcal{Y}, \dots$, which may be mapped into a region of the three dimensional Euclidean space \mathcal{E} . Let P be an arbitrary point of \mathcal{E} . A vector at a point $P \in \mathcal{E}$ is a pair $\mathbf{v}_P \equiv (P, \mathbf{v})$, where $\mathbf{v} \in \mathbb{E}$, and \mathbb{E} is the Euclidean vector space associated with \mathcal{E} . We call P the basic point and \mathbf{v} the vector part of \mathbf{v}_P . The totality of all vectors at P spans a vector space $T_P\mathcal{E}$, referred to as tangent space to \mathcal{E} at P . With an origin O fixed in \mathcal{E} , every point $P \in \mathcal{E}$ may be identified by a position vector $\mathbf{p}_O = (O, \mathbf{p}) \in T_O\mathcal{E}$. As usually in classical continuum mechanics, we shall set $\mathbf{p}_O \equiv \mathbf{p}$, and from the related topics it will be clear what is meant. In this sense, we shall also set \mathbf{p} equal to point P , and we shall speak of the point $\mathbf{p} \in \mathcal{E}$. We shall mainly pursue this nomenclature, and we shall refer to the exact mathematical notion only in some particular cases to explain the issues in more details.

As commonly, we define a configuration of the body to be a map

$$k : \mathcal{B} \rightarrow \mathcal{E} \quad , \quad (9.16)$$

with $k(\mathcal{B})$ an open, simply connected subset of \mathcal{E} . $k(\mathcal{B})$ is denoted as the range in \mathcal{E} occupied by the body \mathcal{B} under the configuration k . Following the nomenclature of classical mechanics, we shall speak from the point $\mathbf{p} \in k(\mathcal{B})$. It is also customary to write $\mathbf{k} : \mathcal{B} \rightarrow \mathcal{E}$ and to set $k(\mathcal{B}) \equiv \mathbf{k}(\mathcal{B})$. A fixed chosen configuration χ_R ,

$$\chi_R : \mathcal{B} \rightarrow \mathcal{E} \quad , \quad (9.17)$$

$$\mathcal{X} \mapsto \mathbf{X} = \chi_R(\mathcal{X}) \quad (9.18)$$

is called reference configuration. A motion of \mathcal{B} in \mathcal{E} is an one-parameter family of configurations χ , parameterized with time $t \in I$ ($I \subset \mathbb{R}$, I : interval), i.e.

$$\chi : \mathcal{B} \times I \rightarrow \mathcal{E} \quad , \quad (9.19)$$

$$(\mathcal{X}, t) \mapsto \mathbf{x} = \chi(\mathcal{X}, t) \quad . \quad (9.20)$$

It is supposed that for fixed time t , function χ possesses an inverse. In general, we have $\mathbf{X} \in T_O\mathcal{E}$, whereas $\mathbf{x} \in T_o\mathcal{E}$, with $o \in \mathcal{E}$ being a further origin in \mathcal{E} . If the motion of the body starts at time t_0 , then the configuration $\chi(\cdot, t_0)$ is called the initial configuration, and we shall write $\mathbf{x}_0 = \chi(\mathcal{X}, t_0)$. Accordingly, the configuration $\chi(\cdot, t)$ is denoted as actual or current configuration. In this paper, we assume the two origins o and O to coincide, and the initial configuration to be equal to the reference configuration, so that $\mathbf{x}_0 \equiv \mathbf{X}$. Furthermore, we write R_R and R_t for the range in \mathcal{E} occupied by the body under the reference and the actual configuration, respectively, $R_R := \chi_R(\mathcal{B}) \equiv \chi(\mathcal{B}, t_0)$, $R_t := \chi(\mathcal{B}, t)$. It is common to call configurations different than the reference configuration as spatial, and to refer to the actual configuration as Eulerian. Since all inverse functions are assumed to exist for fixed t , the motion can be expressed in terms of \mathbf{X} . If no confusion may arise, we shall use the same symbol for this function, as it is common in continuum mechanics,

$$\chi : R_R \times I \rightarrow R_t \quad , \quad (9.21)$$

$$(\mathbf{X}, t) \mapsto \mathbf{x} = \chi(\mathbf{X}, t) \equiv \chi_t(\mathbf{X}) \quad . \quad (9.22)$$

For fixed t , function χ in Eq. (9.22) is denoted as deformation (function) from the reference to the actual configuration. We write TR_R and TR_t for the tangent bundles of R_R and R_t , respectively,

$$TR_R := \bigcup_{\mathbf{X} \in R_R} T_{\mathbf{X}}R_R \quad , \quad TR_t := \bigcup_{\mathbf{x} \in R_t} T_{\mathbf{x}}R_t \quad . \quad (9.23)$$

It is assumed that R_R and R_t are Euclidean manifolds, and that they can be covered by coordinate lines of single coordinate systems, respectively. For convenience, we use Cartesian coordinate systems $\{X^i\}$ for R_R and $\{x^i\}$ for R_t . These induce, respectively, coordinate bases $\mathbf{E}_i \equiv \mathbf{E}^i$ and $\mathbf{e}_i \equiv \mathbf{e}^i$,

$$\mathbf{E}^i \cdot \mathbf{E}_j = \delta_j^i \quad , \quad \mathbf{e}^i \cdot \mathbf{e}_j = \delta_j^i \quad . \quad (9.24)$$

One may think of the coordinate systems $\{X^i\}$ and $\{x^i\}$ to be extended over the whole space \mathcal{E} , and the position vectors \mathbf{X} and \mathbf{x} to be given by $\mathbf{X} = X^i \mathbf{E}_i$ and $\mathbf{x} = x^i \mathbf{e}_i$.

We recall that the tangent space at any point is defined to be an Euclidean vector space. The inner product in this space is denoted by a dot. Clearly, in the tangent space of every point there exists

always an orthonormal basis, so that, with respect to this (perhaps local) basis, the components of the metric tensor are given by the Kronecker delta symbol. If these bases form a field of coordinate basis vectors, tangent to a global coordinate system, then the metric coefficients of the metric on the manifold will be given everywhere by the Kronecker delta symbol. In this case, the metric tensor on the manifold is everywhere the identity tensor of second-order, and the manifold will be Euclidean. However, if it is not possible to select such a coordinate system, then the tangent vector spaces will still be Euclidean, but the metric, and hence the manifold itself, will be not Euclidean. In this case, if we are given the metric coefficients at every point on the manifold, then there do not exist some coordinate transformations rendering the metric coefficients equal to the Kronecker delta. Nevertheless, the components of tensorial quantities will be expressed in terms of the Euclidean product, which hold always in the tangent space at every point.

9.3.2 Deformation gradient tensor

The deformation (9.22) can be characterized by the gradient

$$\frac{\partial \chi}{\partial \mathbf{X}} \equiv \text{GRAD} \chi(\mathbf{X}, t) \quad . \quad (9.25)$$

We distinguish between the operators GRAD and grad, representing the gradient with respect to \mathbf{X} and \mathbf{x} , respectively. In classical mechanics, the basic point of vectors is not mentioned explicitly and $\mathbf{F} = \text{GRAD} \chi$ is regarded as linear map $\mathbf{F} : \mathbb{E} \rightarrow \mathbb{E}$, so that the linear approximation

$$\mathbf{x} - \mathbf{x}_0 = \mathbf{F}(\mathbf{X}_0, t)[\mathbf{X} - \mathbf{X}_0] \quad (9.26)$$

holds, with $\mathbf{x}_0 = \chi(\mathbf{X}_0, t)$ and $\mathbf{X}_0 \in R_R$. From the differential geometrical point of view, \mathbf{F} is the tangent map of χ , i.e.,

$$\mathbf{F} : TR_R \rightarrow TR_t \quad . \quad (9.27)$$

Note that $\mathbf{F}(\mathbf{X}, t)$ is a co-called two-point tensor, which applies to a vector $(\mathbf{X}, \mathbf{W}) \in T_{\mathbf{X}}R_R$ and generates a vector $(\mathbf{x}, \text{GRAD} \chi[\mathbf{W}]) \in T_{\mathbf{x}}R_t$ (cf. Marsden and Hughes [117], Sect. 1.4),

$$\mathbf{F}(\mathbf{X}, t) : T_{\mathbf{X}}R_R \rightarrow T_{\mathbf{x}}R_t \quad , \quad (9.28)$$

$$(\mathbf{X}, \mathbf{W}) \mapsto \mathbf{F}[\mathbf{X}, \mathbf{W}] = (\mathbf{x}, \text{GRAD} \chi[\mathbf{W}]) \quad . \quad (9.29)$$

A two-point tensor consists of two parts. The first one is responsible for the point map, i.e. the shifting of the basic points of vectors. The second part is a linear map, which operates on ordinary vectors in \mathbb{E} , and is represented by $\text{GRAD} \chi$ in the case of \mathbf{F} . Hence, the linear approximation (9.26) has to be interpreted as follows. The origin O is the basic point of all position vectors \mathbf{x} , \mathbf{x}_0 , \mathbf{X} , \mathbf{X}_0 , and therefore $(\mathbf{x} - \mathbf{x}_0)$, $(\mathbf{X} - \mathbf{X}_0) \in T_O\mathcal{E}$. Let $\mathbf{S}_{\mathbf{x}_0}$ be the shifter (cf. Marsden and Hughes [117], Sect. 1.3)

$$\mathbf{S}_{\mathbf{x}_0} : T_{\mathbf{x}_0}R_t \rightarrow T_O\mathcal{E} \quad , \quad (9.30)$$

$$(\mathbf{x}_0, \mathbf{w}) \mapsto \mathbf{S}_{\mathbf{x}_0}[\mathbf{x}_0, \mathbf{w}] := (O, \mathbf{w}) \quad . \quad (9.31)$$

$\mathbf{S}_{\mathbf{x}_0}$ is an orthogonal map, which moves the basic point from \mathbf{x}_0 to the origin O , whereas the vector part \mathbf{w} remains the same. In an analogous manner, we define the shifter $\mathbf{S}_{\mathbf{X}_0}$ by

$$\mathbf{S}_{\mathbf{X}_0} : T_{\mathbf{X}_0}R_R \rightarrow T_O\mathcal{E} \quad , \quad (9.32)$$

$$(\mathbf{X}_0, \mathbf{W}) \mapsto \mathbf{S}_{\mathbf{X}_0}[\mathbf{X}_0, \mathbf{W}] := (O, \mathbf{W}) \quad . \quad (9.33)$$

This way, Eq. (9.26) may be rewritten in the form

$$\mathbf{S}_{\mathbf{x}_0}^{-1}[\mathbf{x} - \mathbf{x}_0] = \mathbf{F}(\mathbf{X}_0, t)\mathbf{S}_{\mathbf{X}_0}^{-1}[\mathbf{X} - \mathbf{X}_0] \quad , \quad (9.34)$$

or equivalently,

$$\mathbf{x} - \mathbf{x}_0 = \left(\mathbf{S}_{\mathbf{x}_0} \mathbf{F}(\mathbf{X}_0, t) \mathbf{S}_{\mathbf{X}_0}^{-1} \right) [\mathbf{X} - \mathbf{X}_0] \quad . \quad (9.35)$$

We turn to the classical notation and write \mathbf{C} and \mathbf{B} for the left and the right Cauchy-Green deformation tensors, respectively,

$$\mathbf{C} = \mathbf{F}^T \mathbf{F} = \mathbf{U}^2 \quad , \quad \mathbf{B} = \mathbf{F} \mathbf{F}^T = \mathbf{V}^2 \quad . \quad (9.36)$$

The tensors \mathbf{U} , \mathbf{V} are symmetric and positive definite and are denoted, respectively, as right and left stretch tensors. They appear in the polar decomposition of \mathbf{F} ,

$$\mathbf{F} = \mathbf{R} \mathbf{U} = \mathbf{V} \mathbf{R} \quad , \quad (9.37)$$

where \mathbf{R} represents a proper orthogonal second-order tensor, referred to as material rotation. In opposite to $\mathbf{F}(\mathbf{X}, t)$, $\mathbf{U}(\mathbf{X}, t)$ is an endomorphism,

$$\mathbf{U}(\mathbf{X}, t) \quad : \quad T_{\mathbf{X}} R_R \quad \rightarrow \quad T_{\mathbf{X}} R_R \quad . \quad (9.38)$$

An immediate consequence from Eq. (9.38) is that $\mathbf{R}(\mathbf{X}, t)$ is a two-point tensor,

$$\mathbf{R}(\mathbf{X}, t) \quad : \quad T_{\mathbf{X}} R_R \quad \rightarrow \quad T_{\mathbf{x}} R_t \quad , \quad (9.39)$$

and thus $\mathbf{V}(\mathbf{X}, t)$ is an endomorphism

$$\mathbf{V}(\mathbf{X}, t) \quad : \quad T_{\mathbf{x}} R_t \quad \rightarrow \quad T_{\mathbf{x}} R_t \quad . \quad (9.40)$$

It is customary in classical continuum mechanics to use the same symbol for a tensor and for the linear map associated with it. Thus, we shall write \mathbf{F} , \mathbf{R} , \mathbf{U} , \mathbf{V} for the linear maps acted by the tensors \mathbf{F} , \mathbf{R} , \mathbf{U} , \mathbf{V} , respectively. Unlike \mathbf{F} , the fields \mathbf{R} , \mathbf{U} , \mathbf{V} need not to satisfy some compatibility conditions, i.e., these fields are not gradients. We say that \mathbf{R} , \mathbf{U} , \mathbf{V} describe incompatible or local deformations. Accordingly, \mathbf{F} describes a compatible or global deformation from the reference to the actual configuration. This will be discussed in more details in the next section.

9.4 Local deformations

Notions like local deformation or local configuration have been discussed by Noll [129] (see also Truesdell and Noll [155], Sects. 22, 34). In the present paper we use the term local configuration, and related notions, in a manner, which is convenient for our purposes. To be more specific, we shall explain the issues for the case of the polar decomposition of the deformation gradient tensor \mathbf{F} .

It has already be mentioned that, in contrast to $\mathbf{F}(\mathbf{X}, t)$, there is no global function on R_R , the gradient of which furnishes $\mathbf{R}(\mathbf{X}, t)$. But for fixed t and given neighbourhood $\mathcal{N}_{\mathbf{R}}(\mathbf{X}) \subset \mathcal{E}$, of the

point $\mathbf{X} \in R_R$, one may find out a class of (infinite many) functions, which map $\mathcal{N}_{\mathbf{R}}(\mathbf{X})$ to a neighbourhood $\mathcal{M}_{\mathbf{R}}(\mathbf{x}, t) \subset \mathcal{E}$, of the point $\mathbf{x} = \chi(\mathbf{X}, t)$, and satisfy the following properties. If $\varrho_{\mathbf{X}}$ belongs to that class, then

$$\varrho_{\mathbf{X}} : \mathcal{N}_{\mathbf{R}}(\mathbf{X}) \times I \rightarrow \mathcal{M}_{\mathbf{R}}(\mathbf{x}, t) := \varrho_{\mathbf{X}}(\mathcal{N}_{\mathbf{R}}(\mathbf{X}), t) \subset \mathcal{E} \quad , \quad (9.41)$$

$$\varrho_{\mathbf{X}}(\mathbf{X}, t) = \mathbf{x} = \chi(\mathbf{X}, t) \quad , \quad (9.42)$$

$$\left. \frac{\partial \varrho_{\mathbf{X}}}{\partial \mathbf{Y}} \right|_{\mathbf{Y}=\mathbf{X}} = \mathbf{R}(\mathbf{X}, t) \quad . \quad (9.43)$$

For $\mathbf{Y} \neq \mathbf{X}$ it will be in general $\varrho_{\mathbf{X}}(\mathbf{Y}, t) \neq \chi(\mathbf{Y}, t)$. This is the reason why we say that $\mathbf{R}(\mathbf{X}, t)$ defines a local deformation at \mathbf{X} (or from \mathbf{X} to \mathbf{x} , or simply from the reference to the current configuration), or that $\mathbf{R}(\mathbf{X}, t)$ induces a local configuration at \mathbf{X} . Clearly, for different points \mathbf{X} , the function $\mathbf{R}(\mathbf{X}, t)$ induces in general different local configurations. Since \mathbf{R} is incompatible, we say also that \mathbf{R} introduces an incompatible deformation from the reference to the current configuration.

The definition of local deformation may be applied to compositions of deformations. Thus, e.g., $\mathbf{U}(\mathbf{X}, t)$ introduces a local deformation at \mathbf{X} . For fixed t and given neighbourhood $\mathcal{N}_{\mathbf{U}}(\mathbf{X}) \subset \mathcal{E}$, of the point $\mathbf{X} \in R_R$, one can select a class of functions $\zeta_{\mathbf{X}}$, with

$$\zeta_{\mathbf{X}} : \mathcal{N}_{\mathbf{U}}(\mathbf{X}) \times I \rightarrow \mathcal{M}_{\mathbf{U}}(\mathbf{X}, t) := \zeta_{\mathbf{X}}(\mathcal{N}_{\mathbf{U}}(\mathbf{X}), t) \subset \mathcal{E} \quad , \quad (9.44)$$

$$\zeta_{\mathbf{X}}(\mathbf{X}, t) = \mathbf{X} \quad , \quad (9.45)$$

$$\left. \frac{\partial \zeta_{\mathbf{X}}}{\partial \mathbf{Y}} \right|_{\mathbf{Y}=\mathbf{X}} = \mathbf{U}(\mathbf{X}, t) \quad , \quad (9.46)$$

and $\zeta_{\mathbf{X}}(\mathbf{Y}, t) \neq \mathbf{Y}$ for $\mathbf{Y} \neq \mathbf{X}$, generally. In addition,

$$\mathbf{F}(\mathbf{X}, t) = \left. \frac{\partial \varrho_{\mathbf{X}}(\zeta_{\mathbf{X}}(\mathbf{Y}, t), t)}{\partial \mathbf{Y}} \right|_{\mathbf{Y}=\mathbf{X}} = \left. \frac{\partial \varrho_{\mathbf{X}}(\mathbf{Y}, t)}{\partial \mathbf{Y}} \right|_{\mathbf{Y}=\mathbf{X}} \left. \frac{\partial \zeta_{\mathbf{X}}(\mathbf{Y}, t)}{\partial \mathbf{Y}} \right|_{\mathbf{Y}=\mathbf{X}} = \mathbf{R}(\mathbf{X}, t) \mathbf{U}(\mathbf{X}, t) \quad . \quad (9.47)$$

All manipulations in this equation are well defined, as $\mathcal{M}_{\mathbf{U}}(\mathbf{X}, t) \cap \mathcal{N}_{\mathbf{R}}(\mathbf{X})$ is an open neighbourhood of \mathbf{X} , and in particular, one may set $\mathcal{N}_{\mathbf{R}}(\mathbf{X}) = \mathcal{M}_{\mathbf{U}}(\mathbf{X}, t)$.

Analogously, $\mathbf{V}(\mathbf{X}, t)$ defines a local deformation at $\mathbf{x} = \chi(\mathbf{X}, t)$. There are neighbourhoods $\mathcal{N}_{\mathbf{V}}(\mathbf{x}, t) \subset \mathcal{E}$, of the point $\mathbf{x} = \chi(\mathbf{X}, t) \in R_t$, and a class of functions $\mathbf{z}_{\mathbf{x}}$, with

$$\mathbf{z}_{\mathbf{x}} : \mathcal{N}_{\mathbf{V}}(\mathbf{x}, t) \rightarrow \mathcal{M}_{\mathbf{V}}(\mathbf{x}, t) := \mathbf{z}_{\mathbf{x}}(\mathcal{N}_{\mathbf{V}}(\mathbf{x}, t), t) \subset \mathcal{E} \quad , \quad (9.48)$$

$$\mathbf{z}_{\mathbf{x}}(\mathbf{x}, t) = \mathbf{x} = \chi(\mathbf{x}, t) \quad , \quad (9.49)$$

$$\left. \frac{\partial \mathbf{z}_{\mathbf{x}}}{\partial \mathbf{y}} \right|_{\mathbf{y}=\mathbf{x}} = \mathbf{V}(\chi^{-1}(\mathbf{x}, t), t) \quad . \quad (9.50)$$

Especially, one might chose $\mathcal{N}_{\mathbf{V}}(\mathbf{x}, t) = \mathcal{M}_{\mathbf{R}}(\mathbf{x}, t)$, so that

$$\mathbf{F}(\mathbf{X}, t) = \left. \frac{\partial \mathbf{z}_{\mathbf{x}}(\varrho_{\mathbf{X}}(\mathbf{Y}, t), t)}{\partial \mathbf{Y}} \right|_{\mathbf{Y}=\mathbf{X}} = \left. \frac{\partial \mathbf{z}_{\mathbf{x}}(\mathbf{y}, t)}{\partial \mathbf{y}} \right|_{\mathbf{y}=\chi(\mathbf{X}, t)} \left. \frac{\partial \varrho_{\mathbf{X}}(\mathbf{Y}, t)}{\partial \mathbf{Y}} \right|_{\mathbf{Y}=\mathbf{X}} = \mathbf{V}(\mathbf{X}, t) \mathbf{R}(\mathbf{X}, t) \quad . \quad (9.51)$$

Summarizing, let Ψ be a linear map

$$\Psi : TR_R \times I \rightarrow TR_t \quad , \quad (9.52)$$

$$\Psi(\mathbf{X}, t) : T_{\mathbf{X}}R_R \times I \rightarrow T_{\mathbf{X}}R_t . \quad (9.53)$$

We say, that Ψ is a local or incompatible deformation (tensor) field from the reference to the actual configuration, whenever $\Psi(\mathbf{X}, t)$ does not satisfy compatibility conditions. Thus, \mathbf{F} is a compatible or global deformation field, for which there exists a global deformation function $\chi(\cdot, t)$. On the contrary, \mathbf{R} is an incompatible deformation field from the reference to the actual configuration. This point of view can be generalized to arbitrary configurations, by choosing in Eq. (9.52), instead of TR_R or TR_t , the tangent bundle of arbitrary configurations. This way, \mathbf{U} , \mathbf{V} are incompatible deformation fields from the reference to the reference and from the actual to the actual configuration, respectively.

Following a proposal of Cross [31], the definition of a local deformation can be extended to a 2-local deformation as follows. Let, for instance, (Ψ, \mathcal{P}) be a pair of a second-order tensor Ψ and a third-order tensor \mathcal{P} , the latter being symmetric with respect to the two last indices. We define Ψ as in Eqs. (9.52), (9.53), while \mathcal{P} is defined to be a field on R_R and to act as linear map like the third-order tensor GRADF. We say that the pair $(\Psi(\mathbf{X}, t), \mathcal{P}(\mathbf{X}, t))$ defines, for fixed t , a (second-gradient) 2-local deformation at \mathbf{X} . That means, for given $\mathcal{N}(\mathbf{X})$ there exists a class of functions $\xi_{\mathbf{X}}(\cdot, t)$ on $\mathcal{N}(\mathbf{X})$, with

$$\xi_{\mathbf{X}}(\mathbf{X}, t) = \mathbf{x} = \chi(\mathbf{X}, t) , \quad (9.54)$$

$$\left. \frac{\partial \xi_{\mathbf{X}}}{\partial \mathbf{Y}} \right|_{\mathbf{Y}=\mathbf{X}} = \Psi(\mathbf{X}, t) , \quad (9.55)$$

$$\left. \frac{\partial^2 \xi_{\mathbf{X}}}{\partial \mathbf{Y} \partial \mathbf{Y}} \right|_{\mathbf{Y}=\mathbf{X}} = \mathcal{P}(\mathbf{X}, t) . \quad (9.56)$$

Eq. (9.56) is the reason why the symmetry of $\mathcal{P}(\mathbf{X}, t)$ has been required. It is emphasized that $\frac{\partial \Psi}{\partial \mathbf{X}} \neq \mathcal{P}$ generally, and hence $\frac{\partial \Psi}{\partial \mathbf{X}}$ needs not obey some symmetry conditions.

9.5 Convective coordinates

For what follows, it is convenient to use the coordinate system $\{X^i\}$ as a convective one. Consequently, the Cartesian coordinate lines in R_R of the coordinate system $\{X^i\}$ represent material lines, which deform in the current configuration, to form the coordinate lines of the convective coordinate system. To a material point will be assigned in R_R and R_t the same values of convective coordinates X^i , but the corresponding local coordinate basis will change. If \mathbf{E}_i and \mathbf{g}_i are the basis vectors of the convective coordinate system $\{X^i\}$ for the same material point in R_R and R_t , respectively, then

$$\mathbf{g}_i = \mathbf{F}\mathbf{E}_i , \quad \mathbf{g}^i = \mathbf{F}^{T-1}\mathbf{E}^i , \quad \mathbf{g}^i \cdot \mathbf{g}_j = \delta_j^i , \quad (9.57)$$

$$g_{ij} = \mathbf{g}_i \cdot \mathbf{g}_j = \mathbf{E}_i \cdot \mathbf{C}\mathbf{E}_j , \quad g^{ij} = \mathbf{g}^i \cdot \mathbf{g}^j = \mathbf{E}^i \cdot \mathbf{C}^{-1}\mathbf{E}^j . \quad (9.58)$$

Between the two basis fields $\{\mathbf{e}_i\}$ and $\{\mathbf{g}_i\}$, assigned to the manifold R_t , there are relations

$$\mathbf{g}_j = \frac{\partial x^i}{\partial X^j} \mathbf{e}_i , \quad \mathbf{g}^i = \frac{\partial X^i}{\partial x^j} \mathbf{e}^j . \quad (9.59)$$

These, together with the formula

$$\mathbf{e}^k \frac{\partial}{\partial x^k} = \mathbf{e}^k \frac{\partial X^m}{\partial x^k} \frac{\partial}{\partial X^m} , \quad (9.60)$$

imply

$$\mathbf{e}^k \frac{\partial}{\partial x^k} = \mathbf{g}^m \frac{\partial}{\partial X^m} \quad . \quad (9.61)$$

Then, on the one hand

$$\mathbf{F} = F_j^i \mathbf{e}_i \otimes \mathbf{E}^j = \delta_j^i \mathbf{g}_i \otimes \mathbf{E}^j \quad , \quad F_j^i := \frac{\partial x^i}{\partial X^j} \quad , \quad (9.62)$$

$$\mathbf{F}^{-1} = (\mathbf{F}^{-1})_j^i \mathbf{E}_i \otimes \mathbf{e}^j = \delta_j^i \mathbf{E}_i \otimes \mathbf{g}^j \quad , \quad (\mathbf{F}^{-1})_j^i := \frac{\partial X^i}{\partial x^j} \quad . \quad (9.63)$$

On the other hand, for any vector field

$$\mathbf{b} = \mathbf{b}(\mathbf{x}, t) = \mathbf{b}(\chi(\mathbf{X}, t), t) \quad , \quad (9.64)$$

with \mathbf{b} being in TR_R , or TR_t , or in the tangent bundle associated to some other configuration, we have

$$\text{GRADb} = \frac{\partial \mathbf{b}}{\partial X^i} \otimes \mathbf{E}^i \quad , \quad (9.65)$$

$$\text{gradb} = \frac{\partial \mathbf{b}}{\partial x^i} \otimes \mathbf{e}^i = \frac{\partial \mathbf{b}}{\partial X^i} \otimes \mathbf{g}^i \quad . \quad (9.66)$$

9.6 Relative gradient

For an Eulerian vector field \mathbf{b} , $\mathbf{b}(\mathbf{x}, t) \in T_{\mathbf{x}}R_t$, we conclude from Eqs. (9.66), that

$$\text{gradb} = (\text{GRADb})\mathbf{F}^{-1} \quad , \quad (9.67)$$

or

$$\text{GRADb} = (\text{gradb})\mathbf{F} \quad . \quad (9.68)$$

According to Noll [129], these equations suggest to introduce relative gradients related to an incompatible deformation field Ψ (cf. Eqs. (9.52), (9.53), or Eq. (9.55)). For example, looking at (9.67), we define the relative gradient $\bar{\nabla}_{\Psi}\mathbf{b}$ by

$$\bar{\nabla}_{\Psi}\mathbf{b} := (\text{GRADb})\Psi^{-1} \quad . \quad (9.69)$$

In analogy to Eq. (9.57), we introduce a basis $\{(\mathbf{g}_{\Psi})_i\}$ by

$$(\mathbf{g}_{\Psi})_i := \Psi \mathbf{E}_i \quad , \quad (\mathbf{g}_{\Psi})^i := \Psi^{T-1} \mathbf{E}^i \quad . \quad (9.70)$$

Then,

$$\bar{\nabla}_{\Psi}\mathbf{b} := \left(\frac{\partial \mathbf{b}}{\partial X^i} \otimes \mathbf{E}^i \right) \Psi^{-1} = \frac{\partial \mathbf{b}}{\partial X^i} \otimes (\mathbf{g}_{\Psi})^i \quad . \quad (9.71)$$

It is of interest to gain the components of $\bar{\nabla}_{\Psi}\mathbf{b}$ relative to the basis $\{(\mathbf{g}_{\Psi})_i\}$. To this end, we assume the component formulas

$$\mathbf{b} = b^m (\mathbf{g}_{\Psi})_m \quad , \quad (9.72)$$

$$\boldsymbol{\Psi} = \Psi_j^i \mathbf{e}_i \otimes \mathbf{E}^j \quad , \quad (9.73)$$

$$\boldsymbol{\Psi}^{-1} = (\boldsymbol{\Psi}^{-1})_n^m \mathbf{E}_m \otimes \mathbf{e}^n \quad , \quad (9.74)$$

so that

$$(\mathbf{g}_{\boldsymbol{\Psi}})_i = \Psi_j^i \mathbf{e}_j \quad , \quad \mathbf{e}_j = (\boldsymbol{\Psi}^{-1})_j^i (\mathbf{g}_{\boldsymbol{\Psi}})_i \quad , \quad (9.75)$$

and

$$\frac{\partial (\mathbf{g}_{\boldsymbol{\Psi}})_m}{\partial X^i} = (\boldsymbol{\Psi}^{-1})_n^j \frac{\partial \Psi_m^n}{\partial X^i} (\mathbf{g}_{\boldsymbol{\Psi}})_j \quad . \quad (9.76)$$

After inserting in Eq. (9.71),

$$\begin{aligned} \bar{\nabla}_{\boldsymbol{\Psi}} \mathbf{b} &= \frac{\partial b^m}{\partial X^i} (\mathbf{g}_{\boldsymbol{\Psi}})_m \otimes (\mathbf{g}_{\boldsymbol{\Psi}})^i + b^m \frac{\partial (\mathbf{g}_{\boldsymbol{\Psi}})_m}{\partial X^i} \otimes (\mathbf{g}_{\boldsymbol{\Psi}})^i \\ &= \frac{\partial b^m}{\partial X^i} (\mathbf{g}_{\boldsymbol{\Psi}})_m \otimes (\mathbf{g}_{\boldsymbol{\Psi}})^i + (\boldsymbol{\Psi}^{-1})_n^j \frac{\partial \Psi_m^n}{\partial X^i} b^m (\mathbf{g}_{\boldsymbol{\Psi}})_j \otimes (\mathbf{g}_{\boldsymbol{\Psi}})^i \quad , \end{aligned} \quad (9.77)$$

or

$$\bar{\nabla}_{\boldsymbol{\Psi}} \mathbf{b} = \left(\frac{\partial b^j}{\partial X^i} + (\Lambda_{\boldsymbol{\Psi}})^j_{im} b^m \right) (\mathbf{g}_{\boldsymbol{\Psi}})_j \otimes (\mathbf{g}_{\boldsymbol{\Psi}})^i \quad , \quad (9.78)$$

with

$$(\Lambda_{\boldsymbol{\Psi}})^j_{im} = (\boldsymbol{\Psi}^{-1})_n^j \frac{\partial \Psi_m^n}{\partial X^i} \quad (9.79)$$

relative to $(\mathbf{g}_{\boldsymbol{\Psi}})_i$.

The following remarks may be of interest.

Remark 1. The basis $\{(\mathbf{g}_{\boldsymbol{\Psi}})_i\}$ is anholonomic. The objects of anholonomy $(\mathcal{C}_{\boldsymbol{\Psi}})^s_{rm}$ for this basis (cf. Schouten [141], p. 100) read

$$(\mathcal{C}_{\boldsymbol{\Psi}})^s_{rm} = (\boldsymbol{\Psi}^{-1})_k^s \left(\Psi_r^n \frac{\partial \Psi_m^k}{\partial x^n} - \Psi_m^n \frac{\partial \Psi_r^k}{\partial x^n} \right) \quad . \quad (9.80)$$

Remark 2. The relative gradient has been introduced with respect to the map $\boldsymbol{\Psi}$, which is a two point tensor. However, it is a straightforward task to generalize it for arbitrary incompatible deformations, or even for compositions of incompatible deformations. The vector \mathbf{b} may also belong to tangent spaces in the reference, the current, or another spatial configuration. For example, the relative gradient of the vector field \mathbf{b} in Eqs. (9.64), (9.72), related to \mathbf{U} reads

$$\nabla_{\mathbf{U}} \mathbf{b} = (\text{GRAD} \mathbf{b}) \mathbf{U}^{-1} \quad . \quad (9.81)$$

Remark 3. Eq. (9.68) suggests to define relative gradients in conjunction to the operator grad . For example, a relative gradient of the vector field \mathbf{b} in Eqs. (9.64), (9.72), related to \mathbf{V} , may be defined through

$$\nabla_{\mathbf{V}} \mathbf{b} := (\text{grad} \mathbf{b}) \mathbf{V} \quad . \quad (9.82)$$

This offers the possibilities

$$\bar{\nabla}_{\mathbf{R}}\mathbf{b} := (\text{GRAD}\mathbf{b})\mathbf{R}^{-1} \quad , \quad (9.83)$$

$$\tilde{\nabla}_{\mathbf{R}}\mathbf{b} = (\text{grad}\mathbf{b})\mathbf{R} \quad . \quad (9.84)$$

After comparison with Eqs. (9.81), (9.82), we see that

$$\bar{\nabla}_{\mathbf{R}}\mathbf{b} = \nabla_{\mathbf{v}}\mathbf{b} \quad , \quad (9.85)$$

$$\tilde{\nabla}_{\mathbf{R}}\mathbf{b} = \nabla_{\mathbf{U}}\mathbf{b} \quad . \quad (9.86)$$

Remark 4. Relative gradients related to incompatible deformations are not covariant derivatives. To see this, it suffices to concentrate ourself on Eqs. (9.69), (9.78), with Ψ given by (9.52), (9.53). We recall that every covariant derivative $\nabla_{\mathbf{u}}\mathbf{v}$, of the vector \mathbf{v} along the vector \mathbf{u} , has to satisfy Leibniz's rule (see Eq. (9.268) in Sect. 9.9). By inspecting Eq. (9.78), it may be inferred that the relative gradient $\bar{\nabla}_{\Psi}\mathbf{b}$ does not satisfy this rule. A further aspect may highlight by introducing the notation (cf. Eq. (9.272))

$$\partial_i(\cdot) := \frac{\partial(\cdot)}{\partial X^i} = F^n_i \frac{\partial(\cdot)}{\partial x^n} \quad , \quad (9.87)$$

$$(\partial_{\Psi})_i(\cdot) := \Psi^n_i \frac{\partial(\cdot)}{\partial x^n} = \Psi^n_i (\mathbf{F}^{-1})^k_n \frac{\partial(\cdot)}{\partial X^k} \quad . \quad (9.88)$$

If $\bar{\nabla}_{\Psi}\mathbf{b}$ should have to be a covariant derivative, then, instead of the term $\frac{\partial b^j}{\partial X^i} = \partial_i b^j$ on the righthand side of Eq. (9.78), it should stay the term $(\partial_{\Psi})_i b^j$, which describes the derivative of b^j along $(\mathbf{g}_{\Psi})_i$.

Remark 5. Since $\bar{\nabla}_{\Psi}\mathbf{b}$ is not a covariant derivative, quantities $(\Lambda_{\Psi})^j_{im}$ are not objects of a connection for R_t , relative to the basis $\{(\mathbf{g}_{\Psi})_i\}$. Hence, the question arises how do transform objects $(\Lambda_{\Psi})^j_{im}$ under a change of basis. Let $\{(\mathbf{g}_{\Psi}^*)_i\}$ be another basis field in R_t , related to the basis $\{(\mathbf{g}_{\Psi})_i\}$ via

$$(\mathbf{g}_{\Psi}^*)_i = A^l_i (\mathbf{g}_{\Psi})_l \quad , \quad (\mathbf{g}_{\Psi}^*)^i = (\mathbf{A}^{-1})^i_l (\mathbf{g}_{\Psi})^l \quad . \quad (9.89)$$

It is shown in Sect. 9.11, that

$$\bar{\nabla}_{\Psi}\mathbf{b} = \{\partial_i^* b^{*n} + (\Lambda_{\Psi}^*)^n_{im} b^{*m}\} (\mathbf{g}_{\Psi}^*)_n \otimes (\mathbf{g}_{\Psi}^*)^i \quad , \quad (9.90)$$

with

$$(\Lambda_{\Psi}^*)^n_{im} = (\mathbf{A}^{-1})^n_s A^k_i A^r_m (\Lambda_{\Psi})^s_{kr} + (\mathbf{A}^{-1})^n_r A^j_i \frac{\partial A^r_m}{\partial X^j} \quad (9.91)$$

and

$$\mathbf{b} = b^{*m} (\mathbf{g}_{\Psi}^*)_m \quad , \quad b^{*m} = (\mathbf{A}^{-1})^m_j b^j \quad . \quad (9.92)$$

On comparing Eq. (9.91) with (9.278), we see that $(\Lambda_{\Psi})^s_{kr}$ are not objects of connection for the manifold R_t , because of the term $A^j_i \frac{\partial A^r_m}{\partial X^j} = \partial_i^* A^r_m$ on the righthand side of Eq. (9.91). If this term were replaced e.g. by $(\partial_{\Psi}^*)_i A^r_m = A^j_i (\partial_{\Psi})_j A^r_m$, then $(\Lambda_{\Psi})^s_{kr}$ were objects of connection for R_t with respect to $\{(\mathbf{g}_{\Psi})_i\}$.

9.7 Covariant derivatives related to incompatible deformations

In the last section we proved that the relative gradient $\bar{\nabla}_{\Psi}\mathbf{b}$ is not a covariant derivative in R_t . Nevertheless, there are several possibilities to bring $\bar{\nabla}_{\Psi}\mathbf{b}$ in contact with a covariant derivative. Surely, one way arises from the very definition (9.69), from which it may be recognized, that $\bar{\nabla}_{\Psi}\mathbf{b}$ is immediately related to $\text{GRAD}\mathbf{b}$, the latter being a covariant derivative in R_R . Apart from this, we shall study in this section three further possibilities to relate $\bar{\nabla}_{\Psi}\mathbf{b}$ to a covariant derivative. The results we shall obtain, can be adjusted accordingly to establish also connections of the relative gradient $\tilde{\nabla}_{\Psi}\mathbf{b} := (\text{grad}\mathbf{b})\Psi$ (cf. Eq. (9.84)) with corresponding covariant derivatives.

9.7.1 Transformation of covariant derivatives – relative covariant derivative

We shall rewrite the relation between $\bar{\nabla}_{\Psi}\mathbf{b}$ and $\text{GRAD}\mathbf{b}$, given by Eq. (9.69), in another form, and this will serve as starting point to introduce so-called relative covariant derivatives. To be definite, let \mathbf{B} be a Lagrangean vector field, $\mathbf{B}(\mathbf{X}, t) \in T_{\mathbf{X}}R_R$, which arises from the Eulerian vector field \mathbf{b} (cf. Eq. (9.72)) by the pull-back transformation

$$\mathbf{B} := \Psi^{-1}\mathbf{b} = b^i\mathbf{E}_i \quad . \quad (9.93)$$

Then,

$$\begin{aligned} \bar{\nabla}_{\Psi}\mathbf{b} &= \left(\frac{\partial\mathbf{b}}{\partial X^i} \otimes \mathbf{E}^i \right) \Psi^{-1} \\ &= \Psi \left(\frac{\partial\mathbf{B}}{\partial X^i} + \Psi^{-1} \frac{\partial\Psi}{\partial X^i} \mathbf{B} \otimes \mathbf{E}^i \right) \Psi^{-1} \\ &= \Psi \left\{ \left(\frac{\partial b^j}{\partial X^i} + (\Lambda_{\Psi})^j_{ik} b^k \right) \mathbf{E}_j \otimes \mathbf{E}^i \right\} \Psi^{-1} \quad , \end{aligned} \quad (9.94)$$

with $(\Lambda_{\Psi})^j_{ik}$ given by Eq. (9.79). The term enclosed in curly braces is a covariant derivative of \mathbf{B} in the space R_R , with $(\Lambda_{\Psi})^j_{ik}$ being, with respect to $\{\mathbf{E}_i\}$, the objects of connection for R_R . On defining

$$\tilde{\nabla}_{\Psi}\mathbf{B} := \left(\frac{\partial b^j}{\partial X^i} + (\Lambda_{\Psi})^j_{il} b^l \right) \mathbf{E}_j \otimes \mathbf{E}^i \quad , \quad (9.95)$$

we have

$$\bar{\nabla}_{\Psi}\mathbf{b} = \Psi \left(\tilde{\nabla}_{\Psi}\mathbf{B} \right) \Psi^{-1} \quad . \quad (9.96)$$

This asserts, that the relative gradient $\bar{\nabla}_{\Psi}\mathbf{b}$ of the Eulerian vector \mathbf{b} , can be generated from the covariant derivative $\tilde{\nabla}_{\Psi}\mathbf{B}$, of the Lagrangean vector \mathbf{B} , by push-forward transformation of the latter by Ψ . This point of view goes back to Le and Stumpf [98, 99], who studied such approaches within a plasticity theory based on the multiplicative decomposition of the deformation gradient tensor into elastic and plastic parts. Note that objects like $(\Lambda_{\Psi})^j_{ik}$ in Eq. (9.79) have been often regarded as objects of connection for a manifold (see e.g. [9, 129, 99, 120, 27, 96]). Moreover, it has been argued that such objects of connection are not torsion-free. In fact, after inserting Eq. (9.79) into Eq. (9.289), we obtain the components of the torsion tensor \mathcal{T}_{Ψ} relative to the coordinate basis $\{\mathbf{E}_i\}$,

$$(\mathcal{T}_{\Psi})^j_{im} = (\Psi^{-1})^j_k \left(\frac{\partial\Psi^k_m}{\partial X^i} - \frac{\partial\Psi^k_i}{\partial X^m} \right) \quad , \quad (9.97)$$

which are non-vanishing in general, implying that the connection is non-torsion-free. Furthermore, it is an immediate consequence of Eq. (9.292), that the Riemann curvature tensor of that connection vanishes,

$$\begin{aligned}
 (\mathcal{R}_\Psi)^r{}_{ijm} &:= \frac{\partial}{\partial X^j} \left\{ (\Psi^{-1})^r{}_s \frac{\partial \Psi_i^s}{\partial X^m} \right\} - \frac{\partial}{\partial X^m} \left\{ (\Psi^{-1})^r{}_s \frac{\partial \Psi_i^s}{\partial X^j} \right\} \\
 &+ (\Psi^{-1})^r{}_s \frac{\partial \Psi_p^s}{\partial X^j} (\Psi^{-1})^p{}_q \frac{\partial \Psi_i^q}{\partial X^m} - (\Psi^{-1})^r{}_s \frac{\partial \Psi_p^s}{\partial X^m} (\Psi^{-1})^p{}_q \frac{\partial \Psi_i^q}{\partial X^j} = 0 \quad .
 \end{aligned} \tag{9.98}$$

That is, the space R_R endowed with connection $(\Lambda_\Psi)^j{}_{im}$, relative to $\{\mathbf{E}_i\}$, is flat.

Finally, if Ψ is not orthogonal, then the space R_R can be endowed with a non-Euclidean metric, which arises from the Euclidean one in R_t , by pull-back transformation. To elaborate, let \mathbf{a}, \mathbf{b} be two arbitrary Eulerian vector fields, and $\mathbf{A} := \Psi^{-1}\mathbf{a}$, $\mathbf{B} := \Psi^{-1}\mathbf{b}$, corresponding Lagrangean counterparts. Then,

$$\mathbf{g}(\mathbf{a}, \mathbf{b}) := \mathbf{a} \cdot \mathbf{b} \equiv \mathbf{a} \cdot \mathbf{1b} \tag{9.99}$$

defines the Euclidean metric on R_t , and

$$\tilde{\mathbf{G}}(\mathbf{A}, \mathbf{B}) := \mathbf{g}(\mathbf{a}, \mathbf{b}) = \mathbf{A} \cdot (\Psi^T \Psi) \mathbf{B} \tag{9.100}$$

defines a non-Euclidean metric on R_R . In fact, $\Psi^T \Psi$ is symmetric and positive definite. The components of $\tilde{\mathbf{G}}$ with respect to $\{\mathbf{E}_i\}$ are

$$\tilde{G}_{ij} = \Psi_i^k \delta_{kl} \Psi_j^l = (\mathbf{g}_\Psi)_i \cdot (\mathbf{g}_\Psi)_j \quad . \tag{9.101}$$

Since Ψ is incompatible deformation, Ψ_i^k is not a Jacobi matrix attributed to a change of coordinates. Therefore, there does not exist a global coordinate system, so that the components of $\tilde{\mathbf{G}}$ may be expressed by the Kronecker delta relative to this system, and consequently $\tilde{\mathbf{G}}$ introduces a non-Euclidean metric on R_R . Also with respect to the metric $\tilde{\mathbf{G}}$, the connection is metric. This can be verified by using Eqs. (9.101), (9.79) into Eq. (9.291),

$$\begin{aligned}
 -\mathcal{Q}_{lki} &= \frac{\partial(\Psi_i^m \Psi_k^m)}{\partial X^l} - (\Lambda_\Psi)^m{}_{li} \Psi_m^n \Psi_k^n - (\Lambda_\Psi)^m{}_{lk} \Psi_i^n \Psi_m^n \\
 &= \frac{\partial \Psi_i^m}{\partial X^l} \Psi_k^m + \Psi_i^m \frac{\partial \Psi_k^m}{\partial X^l} - (\Psi^{-1})_n^m \frac{\partial \Psi_i^n}{\partial X^l} \Psi_m^j \Psi_k^j - (\Psi^{-1})_n^m \frac{\partial \Psi_k^n}{\partial X^l} \Psi_i^j \Psi_m^j = 0 \quad .
 \end{aligned} \tag{9.102}$$

Summarizing, the space R_R may be viewed as non-Riemannian and non-Euclidean manifold, endowed with the metric tensor field $\tilde{\mathbf{G}}$, and a metric but non-symmetric connection, with objects $(\Lambda_\Psi)^j{}_{im}$ relative to the basis $\{\mathbf{E}_i\}$.

Clearly, instead of the special connection $(\Lambda_\Psi)^j{}_{il}$, one might deal with an arbitrary connection $\Lambda^j{}_{ik}$, in order to define a general covariant derivative $\tilde{\nabla} \mathbf{B}$ for R_R

$$\tilde{\nabla} \mathbf{B} := \left(\frac{\partial b^j}{\partial X^i} + \Lambda^j{}_{il} b^l \right) \mathbf{E}_j \otimes \mathbf{E}^i \quad . \tag{9.103}$$

After push-forward transformation by Ψ (cf. Eq. (9.96)),

$$\nabla \mathbf{b} := \Psi \left(\tilde{\nabla} \mathbf{B} \right) \Psi^{-1} = \left(\frac{\partial b^j}{\partial X^i} + \Lambda^j{}_{il} b^l \right) (\mathbf{g}_\Psi)_j \otimes (\mathbf{g}_\Psi)^i \quad . \tag{9.104}$$

As before, Λ_{il}^j does not introduce a connection for R_t , and $\nabla \mathbf{b}$ is not a covariant derivative in R_t ; it is only the push-forward transformation through Ψ of the covariant derivative $\tilde{\nabla} \mathbf{B}$. In analogy to $\tilde{\nabla}_{\Psi} \mathbf{b}$, we shall call $\nabla \mathbf{b}$ relative covariant derivative of \mathbf{b} in R_t . Generally, the connection for R_R defined by Λ_{il}^j will be non-symmetric and the associated Riemann curvature tensor will not vanish. Thus, the space R_R endowed with metric $\tilde{\mathbf{G}}$ (see Eq. (9.100)), and the arbitrary connection having Christoffel symbol Λ_{il}^j , will be a non-Riemannian and non-Euclidean manifold, exhibiting non-symmetric and non-metric connection. Covariant derivatives used by Kondo [94] in his non-Riemannian geometry of imperfect crystals may be reconciled with definition (9.103).

9.7.2 Covariant derivatives with respect to local deformations

We investigate the conditions under which the relative gradient $\tilde{\nabla}_{\Psi} \mathbf{b}$ might be related to a covariant derivative referred to a local deformation Ψ . To this end, let $(\Psi(\mathbf{X}, t), \mathcal{P}(\mathbf{X}, t))$ be a 2-local deformation at \mathbf{X} . For fixed t and given neighbourhood $\mathcal{N}_{\Psi}(\mathbf{X}) \subset \mathcal{E}$, of the point $\mathbf{X} \in R_R$, there exists a class of deformations $\mu_{\mathbf{X}}(\cdot, t)$ on $\mathcal{N}_{\Psi}(\mathbf{X})$, which map $\mathcal{N}_{\Psi}(\mathbf{X})$ on the neighbourhood $\mathcal{M}_{\Psi}(\mathbf{x}, t) \subset \mathcal{E}$, of the point $\mathbf{x} = \chi(\mathbf{X}, t) \in R_t$, with

$$\mu_{\mathbf{X}} : \mathcal{N}_{\Psi}(\mathbf{X}) \times I \rightarrow \mathcal{M}_{\Psi}(\mathbf{x}, t) := \mu_{\mathbf{X}}(\mathcal{N}_{\Psi}(\mathbf{X}), t) , \quad (9.105)$$

$$\mu_{\mathbf{X}}(\mathbf{X}, t) = \mathbf{x} = \chi(\mathbf{X}, t) , \quad (9.106)$$

$$\left. \frac{\partial \mu_{\mathbf{X}}(\mathbf{Y}, t)}{\partial \mathbf{Y}} \right|_{\mathbf{Y}=\mathbf{X}} = \Psi(\mathbf{X}, t) = \Psi^i_j \mathbf{e}_i \otimes \mathbf{E}^j , \quad (9.107)$$

$$\left. \frac{\partial^2 \mu_{\mathbf{X}}(\mathbf{Y}, t)}{\partial \mathbf{Y} \partial \mathbf{Y}} \right|_{\mathbf{Y}=\mathbf{X}} = \mathcal{P}(\mathbf{X}, t) = \mathcal{P}^i_{jl} \mathbf{e}_i \otimes \mathbf{E}^j \otimes \mathbf{E}^l . \quad (9.108)$$

As before, $\{\mathbf{E}_i\}$ and $\{\mathbf{e}_j\}$ are coordinate bases belonging, respectively, to the coordinate system $\{X^i\}$ and $\{x^j\}$, which now are viewed to be extended over the whole space \mathcal{E} . We set $\mathbf{Y} = Y^i \mathbf{E}_i$, so that $\mathcal{N}_{\Psi}(\mathbf{X})$ is covered by coordinate lines X^i . These are regarded as convective coordinates for $\mathcal{M}_{\Psi}(\mathbf{x}, t)$, with coordinate basis $\{(\nu_{\mathbf{x}})_i\}$,

$$(\nu_{\mathbf{x}})_i = (\nu_{\mathbf{x}})_i(\mathbf{y}, t) = \frac{\partial \mu_{\mathbf{X}}}{\partial \mathbf{Y}}[\mathbf{E}_i] , \quad (9.109)$$

$$(\nu_{\mathbf{x}})^i = (\nu_{\mathbf{x}})^i(\mathbf{y}, t) = \left(\frac{\partial \mu_{\mathbf{X}}}{\partial \mathbf{Y}} \right)^{T-1}[\mathbf{E}^i] , \quad (9.110)$$

and therefore

$$(\nu_{\mathbf{x}})_i(\mathbf{x}, t) = \Psi(\mathbf{X}, t)[\mathbf{E}_i] = (\mathbf{g}_{\Psi})_i , \quad (9.111)$$

$$(\nu_{\mathbf{x}})^i(\mathbf{x}, t) = \Psi^{T-1}(\mathbf{X}, t)[\mathbf{E}^i] = (\mathbf{g}_{\Psi})^i . \quad (9.112)$$

Consider now an Eulerian vector field \mathbf{b} ,

$$\mathbf{b}(\mathbf{x}, t) = b^i(\mathbf{g}_{\Psi})_i \in T_{\mathbf{x}} R_t , \quad (9.113)$$

and a "local" vector field $\beta_{\mathbf{x}}$ on $\mathcal{M}_{\Psi}(\mathbf{x}, t)$, with $\beta_{\mathbf{x}}(\mathbf{y}, t) = (\beta_{\mathbf{x}})^i (\nu_{\mathbf{x}})_i \in T_{\mathbf{y}} \mathcal{M}_{\Psi}(\mathbf{x}, t)$ and

$$\beta_{\mathbf{x}}(\mathbf{y}, t)|_{\mathbf{y}=\mathbf{x}} = \mathbf{b}(\mathbf{x}, t) , \quad (9.114)$$

$$\left. \frac{\partial \beta_{\mathbf{x}}(\mathbf{y}, t)}{\partial Y^i} \right|_{\mathbf{y}=\mathbf{x}} = \frac{\partial \mathbf{b}(\mathbf{x}, t)}{\partial X^i} . \quad (9.115)$$

For defining a 2-local deformation, two conditions (see Eqs. (9.107), (9.108)) are necessary. Similarly, Eqs. (9.114), (9.115) are two conditions to relate local to global vector fields, and their spacial derivatives. Because of Eqs. (9.115), (9.112),

$$\left. \frac{\partial \boldsymbol{\beta}_{\mathbf{x}}}{\partial \mathbf{y}} \right|_{\mathbf{y}=\mathbf{x}} = \left. \frac{\partial \boldsymbol{\beta}_{\mathbf{x}}}{\partial Y^i} \otimes (\boldsymbol{\nu}_{\mathbf{x}})^i \right|_{\mathbf{y}=\mathbf{x}} = \frac{\partial \mathbf{b}}{\partial X^i} \otimes (\mathbf{g}_{\Psi})^i = \bar{\nabla}_{\Psi} \mathbf{b} \quad . \quad (9.116)$$

As $\frac{\partial \boldsymbol{\beta}_{\mathbf{x}}}{\partial \mathbf{y}}$ is gradient of the local vector field $\boldsymbol{\beta}_{\mathbf{x}}$, defined on $\mathcal{M}_{\Psi}(\mathbf{x}, t)$, Eq. (9.116) asserts that the values of $\bar{\nabla}_{\Psi} \mathbf{b}$ and $\frac{\partial \boldsymbol{\beta}_{\mathbf{x}}}{\partial \mathbf{y}}$ at \mathbf{x} are equal, provided conditions (9.114), (9.115) are fulfilled. To generalize Eq. (9.116) to arbitrary covariant derivatives, we utilize the abbreviation

$$\mathbf{M}_{\mathbf{X}}(\mathbf{Y}, t) := \frac{\partial \boldsymbol{\mu}_{\mathbf{X}}(\mathbf{Y}, t)}{\partial \mathbf{Y}} = (\mathbf{M}_{\mathbf{X}})^i_j \mathbf{e}_i \otimes \mathbf{E}^j \quad , \quad (9.117)$$

so that

$$(\mathbf{M}_{\mathbf{X}})^i_j |_{\mathbf{Y}=\mathbf{x}} = \Psi^i_j \quad , \quad (9.118)$$

$$\left. \frac{\partial (\mathbf{M}_{\mathbf{X}})^i_j}{\partial Y^l} \right|_{\mathbf{Y}=\mathbf{x}} = \mathcal{P}^i_{jl} \quad . \quad (9.119)$$

There is

$$\left. \frac{\partial \boldsymbol{\beta}_{\mathbf{x}}}{\partial Y^i} \right|_{\mathbf{y}=\mathbf{x}} = \left\{ \left(\frac{\partial (\boldsymbol{\beta}_{\mathbf{x}})^j}{\partial Y^i} + (\mathbf{M}_{\mathbf{X}}^{-1})^j_n \frac{\partial ((\mathbf{M}_{\mathbf{X}})^n_m (\boldsymbol{\beta}_{\mathbf{x}})^m)}{\partial X^i} \right) (\boldsymbol{\nu}_{\mathbf{x}})_j \right\}_{\mathbf{y}=\mathbf{x}} \quad , \quad (9.120)$$

$$\frac{\partial \mathbf{b}}{\partial X^i} = \left(\frac{\partial b^j}{\partial X^i} + (\Psi^{-1})^j_n \frac{\partial \Psi^n_m}{\partial X^i} b^m \right) (\mathbf{g}_{\Psi})_j \quad , \quad (9.121)$$

and, from Eqs. (9.114), (9.115),

$$\left. \frac{\partial (\boldsymbol{\beta}_{\mathbf{x}})^j}{\partial Y^i} \right|_{\mathbf{y}=\mathbf{x}} - \frac{\partial b^j}{\partial X^i} = (\Psi^{-1})^j_n \left(\frac{\partial \Psi^n_m}{\partial X^i} - \mathcal{P}^n_{mi} \right) b^m \quad . \quad (9.122)$$

If now an arbitrary covariant derivative on $\mathcal{M}_{\Psi}(\mathbf{x}, t)$ were defined by

$$\left\{ \frac{\partial (\boldsymbol{\beta}_{\mathbf{x}})^j}{\partial Y^i} + \bar{\Lambda}^j_{im} (\boldsymbol{\beta}_{\mathbf{x}})^m \right\} (\boldsymbol{\nu}_{\mathbf{x}})_j \otimes (\boldsymbol{\nu}_{\mathbf{x}})^i \quad , \quad (9.123)$$

with

$$\bar{\Lambda}^j_{im} = \bar{\Lambda}^j_{im}(\mathbf{x}, \mathbf{y}, t) \quad , \quad (9.124)$$

and this were assumed to be equal to $\nabla \mathbf{b}$ at $\mathbf{y} = \mathbf{x}$, then the result (9.104),

$$\nabla \mathbf{b} = \left\{ \frac{\partial b^j}{\partial X^i} + \Lambda^j_{il} b^l \right\} (\mathbf{g}_{\Psi})_j \otimes (\mathbf{g}_{\Psi})^i \quad , \quad (9.125)$$

would be reestablished, with Λ^j_{il} being now defined for $\mathbf{y} = \mathbf{x}$ by

$$\Lambda^j_{il} := \bar{\Lambda}^j_{il} + (\Psi^{-1})^j_n \left(\frac{\partial \Psi^n_l}{\partial X^i} - \mathcal{P}^n_{li} \right) \quad , \quad (9.126)$$

where Eq. (9.122) has been taken into account. As above, $\nabla \mathbf{b}$ does not introduce a covariant derivative on R_t .

9.7.3 Covariant derivatives along material lines

Instead of dealing with neighbourhoods of points \mathbf{X}_0 , one can alternatively concentrate himself on material lines passing through \mathbf{X}_0 . It turns out that this is a rather physical approach, as we shall see in this section. In order to simplify notation, we omit in this section the time t , as it is hold fixed.

Assume, we are given a line Σ_λ on R_R , parameterized by $\lambda \in (-\varepsilon, \varepsilon) \subset \mathbb{R}$, which is described by the position vector $\Sigma \in R_R$,

$$\Sigma(\lambda) = \hat{X}^i(\lambda)\mathbf{E}_i \quad \text{with} \quad \Sigma(\lambda = 0) = \mathbf{X}_0 \quad . \quad (9.127)$$

The tangent vector at λ reads

$$\frac{d\Sigma(\lambda)}{d\lambda} = \frac{d\hat{X}^i}{d\lambda}\mathbf{E}_i \quad . \quad (9.128)$$

Assume Σ_λ to be material line. In classical mechanics, the vector

$$d\mathbf{X} := \frac{d\Sigma}{d\lambda}d\lambda \quad (9.129)$$

is denoted as material line element at $\mathbf{X} = \Sigma(\lambda)$ along Σ_λ .

Now let Ψ be a map of the form (9.52), (9.53), and denote by $\Psi(\lambda)$, $\mathbf{F}(\lambda)$ respectively the restrictions of Ψ , \mathbf{F} on Σ_λ . Due to the deformation process, the material line Σ_λ goes in R_t on the material line σ_λ , described by the position vector $\sigma_t(\lambda) = \chi(\Sigma(\lambda))$, with $\sigma(\lambda = 0) = \mathbf{x}_0 = \chi_t(\mathbf{X}_0)$, and characterized by the tangent vector

$$\frac{d\sigma}{d\lambda} = \mathbf{F}(\lambda)\frac{d\Sigma}{d\lambda} \quad . \quad (9.130)$$

We write $\mathbf{g}_i(\lambda)$ for the restriction of the basis vectors \mathbf{g}_i (cf. Eq. (9.57)) on σ_λ and obtain from (9.128), (9.130)

$$\frac{d\sigma}{d\lambda} = \frac{d\hat{X}^i(\lambda)}{d\lambda}\mathbf{g}_i \quad . \quad (9.131)$$

In classical mechanics, the vector

$$d\mathbf{x} := \frac{d\sigma}{d\lambda}d\lambda \quad (9.132)$$

is called the material line element at $\mathbf{x} = \sigma(\lambda)$ along σ_λ . It follows that relation (9.130) may be indicated as differential equations

$$d\mathbf{x} = \mathbf{F}(\mathbf{X})d\mathbf{X} \quad , \quad (9.133)$$

which may be integrated. However, as Ψ is incompatible deformation field, differential equations of the form

$$d\mathbf{y} = \Psi(\mathbf{X})d\mathbf{X} \quad , \quad (9.134)$$

with \mathbf{X} being in a neighbourhood of $\mathbf{X}_0 \in R_R$, cannot be integrated. The physical meaning of this fact is that a simple connected range around \mathbf{X}_0 in R_R cannot be mapped by $\Psi(\mathbf{X})$, via differential

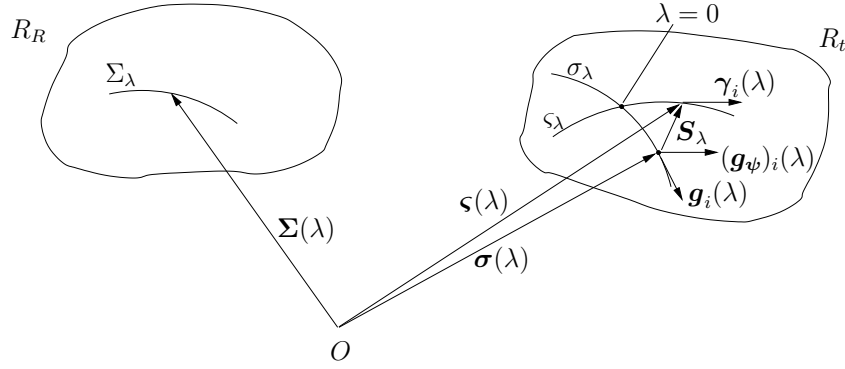

Figure 9.1: Shifter \mathbf{S}_λ moves the basic point $\boldsymbol{\sigma}(\lambda)$ of vectors along σ_λ to the point $\boldsymbol{\zeta}(\lambda)$ along ζ_λ .

equations (9.134), on a simple connected range around \mathbf{x}_0 in R_t . However, it is conceivable, by tearing all material points apart from the body, those which are on the material line Σ_λ , to assign points on a line $\zeta_\lambda \in \mathcal{E}$, which are given as solutions of the differential equation

$$\frac{d\boldsymbol{\zeta}(\lambda)}{d\lambda} = \boldsymbol{\Psi}(\lambda) \frac{d\boldsymbol{\Sigma}(\lambda)}{d\lambda} \quad , \quad \boldsymbol{\zeta}(\lambda = 0) = \mathbf{x}_0 \quad , \quad (9.135)$$

or equivalently by the line integral

$$\boldsymbol{\zeta}(\lambda) = \mathbf{x}_0 + \int_0^\lambda \boldsymbol{\Psi}(\bar{\lambda}) \frac{d\boldsymbol{\Sigma}(\bar{\lambda})}{d\bar{\lambda}} d\bar{\lambda} \quad . \quad (9.136)$$

Here, $\boldsymbol{\Psi}$ denotes the linear part of the two-point tensor map. Alternatively and equivalently, Eq. (9.135) may be expressed in the form

$$\frac{d\boldsymbol{\zeta}(\lambda)}{d\lambda} = \boldsymbol{\Psi}(\lambda) \mathbf{F}^{-1}(\lambda) \frac{d\boldsymbol{\sigma}}{d\lambda} \quad , \quad \boldsymbol{\zeta}(\lambda = 0) = \boldsymbol{\sigma}(\lambda = 0) = \mathbf{x}_0 \quad , \quad (9.137)$$

or

$$\boldsymbol{\zeta}(\lambda) = \mathbf{x}_0 + \int_0^\lambda \boldsymbol{\Psi}(\bar{\lambda}) \mathbf{F}^{-1}(\bar{\lambda}) \frac{d\boldsymbol{\sigma}(\bar{\lambda})}{d\bar{\lambda}} d\bar{\lambda} \quad . \quad (9.138)$$

According to Eqs. (9.52), (9.53), we have

$$\boldsymbol{\Psi}(\lambda) \quad : \quad T_{\boldsymbol{\Sigma}(\lambda)} R_R \quad \rightarrow \quad T_{\boldsymbol{\sigma}(\lambda)} R_t \quad . \quad (9.139)$$

Vectors on σ_λ may be translated to vectors on ζ_λ , with the aid of the shifter \mathbf{S}_λ (see Fig. 9.1),

$$\mathbf{S}_\lambda \quad : \quad T_{\boldsymbol{\sigma}(\lambda)} R_t \quad \rightarrow \quad T_{\boldsymbol{\zeta}(\lambda)} \mathcal{E} \quad . \quad (9.140)$$

For instance, basis vectors $(\mathbf{g}_\Psi)_i(\lambda)$ along σ_λ are translated to basis vectors $\boldsymbol{\gamma}_i(\lambda)$ along ζ_λ ,

$$\boldsymbol{\gamma}_i(\lambda) = \mathbf{S}_\lambda[(\mathbf{g}_\Psi)_i(\lambda)] \quad , \quad (9.141)$$

$$\boldsymbol{\gamma}_i(\lambda = 0) = (\mathbf{g}_\Psi)_i|_{\mathbf{x}=\mathbf{x}_0} \quad . \quad (9.142)$$

Assume $\mathbf{b} = \mathbf{b}(X^k) \in T_{\mathbf{x}} R_t$ to be the Eulerian vector field in Eq. (9.72), with

$$\mathbf{b}(\lambda) = \mathbf{b}(\hat{X}^k(\lambda)) = b^m(\lambda) (\mathbf{g}_\Psi)_i(\lambda) \quad (9.143)$$

being its restriction on σ_λ . To the vector field $\mathbf{b}(\lambda)$ along σ_λ we assign the vector field $\boldsymbol{\beta}(\lambda)$ along ς_λ by

$$\boldsymbol{\beta}(\lambda) := \mathbf{S}_\lambda[\mathbf{b}(\lambda)] = b^m(\lambda)\boldsymbol{\gamma}_m(\lambda) \quad , \quad (9.144)$$

with

$$\boldsymbol{\beta}|_{\lambda=0} = \mathbf{b}|_{\mathbf{x}=\mathbf{x}_0} \quad . \quad (9.145)$$

It is of interest to rewrite Eq. (9.135) by representing vectors as pairs consisting of basic points and vector part. Then, we put $\boldsymbol{\Sigma}'(\lambda) = \left(\boldsymbol{\Sigma}(\lambda), \frac{d\boldsymbol{\Sigma}}{d\lambda} \right)$ for the tangent vector along Σ_λ . Similarly, $\boldsymbol{\sigma}'(\lambda) = \left(\boldsymbol{\sigma}(\lambda), \frac{d\boldsymbol{\sigma}}{d\lambda} \right)$, $\boldsymbol{\varsigma}'(\lambda) = \left(\boldsymbol{\varsigma}(\lambda), \frac{d\boldsymbol{\varsigma}}{d\lambda} \right)$ are the tangent vectors along σ_λ and ς_λ , respectively. This way, the counterpart of Eq. (9.135) reads (see Fig. 9.1)

$$\boldsymbol{\varsigma}'(\lambda) = \mathbf{S}_\lambda \boldsymbol{\Psi}(\lambda) \boldsymbol{\Sigma}'(\lambda) \quad , \quad (9.146)$$

where now $\boldsymbol{\Psi}(\lambda)$ represents the whole two-point tensor map, and not only its linear part. Note also that $\boldsymbol{\varsigma}'(\lambda)$ may be expressed as

$$\boldsymbol{\varsigma}'(\lambda) = \frac{d\hat{X}^i}{d\lambda} \boldsymbol{\gamma}_i(\lambda) \quad , \quad (9.147)$$

by virtue of (9.128), (9.135).

We now define a covariant derivative of $\boldsymbol{\beta}$ along ς_λ by (cf. Eq. (9.284))

$$\frac{D\boldsymbol{\beta}}{D\lambda} := \left(\frac{db^i}{d\lambda} + \bar{\Lambda}^i_{jr} u^j b^r \right) \boldsymbol{\gamma}_i \quad (9.148)$$

with

$$u^j(\lambda) = \frac{d\hat{X}^j(\lambda)}{d\lambda} \quad , \quad (9.149)$$

$$\bar{\Lambda}^i_{jr} = \bar{\Lambda}^i_{jr}(\mathbf{x}_0, \mathbf{x}) \quad , \quad \bar{\Lambda}^i_{jr}(\lambda) = \bar{\Lambda}^i_{jr}(\mathbf{x}_0, \boldsymbol{\varsigma}(\lambda)) \quad , \quad \bar{\Lambda}^i_{jr}|_{\lambda=0} = \Lambda^i_{jr}(\mathbf{x}_0) \quad . \quad (9.150)$$

The map of $\frac{D\boldsymbol{\beta}}{D\lambda}$ on σ_λ by \mathbf{S}_λ^{-1} introduces a derivative (but not a covariant one) $\frac{D\mathbf{b}}{D\lambda}$ of \mathbf{b} along σ_λ ,

$$\frac{D\mathbf{b}}{D\lambda} := \mathbf{S}_\lambda^{-1} \left[\frac{D\boldsymbol{\beta}}{D\lambda} \right] = \left(\frac{db^i(\lambda)}{d\lambda} + \bar{\Lambda}^i_{jr}(\lambda) \frac{d\hat{X}^j(\lambda)}{d\lambda} b^r(\lambda) \right) (\mathbf{g}_\Psi)_i(\lambda) \quad . \quad (9.151)$$

For $\lambda = 0$ we have

$$\begin{aligned} \frac{D\mathbf{b}}{D\lambda} \Big|_{\lambda=0} &= \left(\frac{db^i}{dX^j} + \bar{\Lambda}^i_{jr} b^r \right) \frac{d\hat{X}^j}{d\lambda} (\mathbf{g}_\Psi)_i \Big|_{\lambda=0} \\ &= \left\{ \left(\frac{db^i}{dX^j} + \Lambda^i_{jr} b^r \right) (\mathbf{g}_\Psi)_i \otimes (\mathbf{g}_\Psi)^j \right\} \Big|_{\mathbf{x}=\mathbf{x}_0} \left[\frac{d\hat{X}^k}{d\lambda} (\mathbf{g}_\Psi)_k \right]_{\lambda=0} = (\nabla \mathbf{b})_{\mathbf{x}=\mathbf{x}_0} [\boldsymbol{\varsigma}']_{\lambda=0} \quad , \end{aligned} \quad (9.152)$$

in view of Eqs. (9.142), (9.147), and (9.104) or (9.125). Eqs. (9.151), (9.152) outline the relations between the relative covariant derivative $\nabla \mathbf{b}$, the covariant derivative $\frac{D\boldsymbol{\beta}}{D\lambda}$ and the derivative $\frac{D\mathbf{b}}{D\lambda}$. For the particular choice (cf. Eq. (9.79))

$$\bar{\Lambda}^i_{jr}|_{\lambda=0} \equiv \Lambda^i_{jr}|_{\mathbf{x}=\mathbf{x}_0} = (\Lambda_{\Psi})^i_{jr}|_{\mathbf{x}=\mathbf{x}_0} = \left[(\Psi^{-1})^i_n \frac{\partial \Psi^n_r}{\partial X^j} \right]_{\mathbf{x}=\mathbf{x}_0} \quad (9.153)$$

Eq. (9.152) furnishes

$$\frac{D\mathbf{b}}{D\lambda} \Big|_{\lambda=0} = (\bar{\nabla}_{\Psi} \mathbf{b})_{\mathbf{x}=\mathbf{x}_0} [\boldsymbol{\zeta}']_{\lambda=0} \quad , \quad (9.154)$$

which brings into contact the relative gradient $\bar{\nabla}_{\Psi} \mathbf{b}$ with the derivative $\frac{D\mathbf{b}}{D\lambda}$, and therefore with the covariant derivative $\frac{D\boldsymbol{\beta}}{D\lambda}$. It is perhaps of interest to rewrite Eq. (9.154) as follows

$$\begin{aligned} (\bar{\nabla}_{\Psi} \mathbf{b})_{\mathbf{x}=\mathbf{x}_0} [\boldsymbol{\zeta}']_{\lambda=0} &= \left\{ \left(\frac{db^i}{dX^j} + (\Psi^{-1})^i_n \frac{\partial \Psi^n_r}{\partial X^j} b^r \right) \frac{d\hat{X}^j}{d\lambda} (\mathbf{g}_{\Psi})_i \right\}_{\lambda=0} \\ &= \left\{ \frac{db^i}{d\lambda} (\mathbf{g}_{\Psi})_i + \frac{\partial (\mathbf{g}_{\Psi})_r}{\partial X^j} b^r \frac{d\hat{X}^j}{d\lambda} \right\}_{\lambda=0} \end{aligned} \quad (9.155)$$

or

$$(\bar{\nabla}_{\Psi} \mathbf{b})_{\mathbf{x}=\mathbf{x}_0} [\boldsymbol{\zeta}']_{\lambda=0} = \frac{d\mathbf{b}}{d\lambda} \Big|_{\lambda=0} \quad , \quad (9.156)$$

where use of Eq. (9.76) has been made in Eq. (9.155).

9.8 Use of spatial derivatives in gradient plasticity

In the remainder of the paper we shall employ relative covariant derivatives to introduce kinematical variables for formulating gradient plasticity theories based on decomposition of deformation into elastic and plastic parts. Thereby, we concentrate ourself on non-polar and micropolar continua.

A convenient way to introduce kinematical variables geometrically consists in defining some scalar quantities measuring the deformation process. This approach has been applied in classical plasticity by Haupt and Tsakmakis [81, 82] and Tsakmakis [157]. Here, we shall use similar steps in order to work out the kinematics for gradient theories.

9.8.1 Non-polar continua

9.8.1.1 Strain and curvature tensors

The appropriate geometrical framework is to consider an arbitrary material line Σ_{λ} passing through an arbitrary point $\mathbf{X} \in R_R$, and having there tangent vector $\boldsymbol{\Sigma}'(\mathbf{X})$. The corresponding tangent vector

on the material line σ_λ at $\mathbf{x} = \boldsymbol{\chi}(\mathbf{X}, t) \in R_t$ is $\boldsymbol{\sigma}'(\mathbf{x}, t)$. A scalar quantity measuring the deformation process, used commonly in classical continuum mechanics, reads

$$\Delta_s(\mathbf{X}, t) := \frac{1}{2}(\boldsymbol{\sigma}' \cdot \boldsymbol{\sigma}' - \boldsymbol{\Sigma}' \cdot \boldsymbol{\Sigma}') \quad , \quad (9.157)$$

which does not vanish only for non-rigid body motions of the considered point. Usually, Eq. (9.130) is appealed,

$$\boldsymbol{\sigma}' = \mathbf{F}\boldsymbol{\Sigma}' \quad , \quad (9.158)$$

in order to express the scalar difference Δ_s "form-invariantly" in terms of the Green strain tensor $\mathbf{E} = \frac{1}{2}(\mathbf{C} - \mathbf{1})$, operating in tangent spaces of R_R , or the Almansi strain tensor \mathbf{A} , operating in tangent spaces of R_t ,

$$\begin{aligned} \Delta_s &= \boldsymbol{\Sigma}' \cdot \mathbf{E}\boldsymbol{\Sigma}' = \mathbf{E}[\boldsymbol{\Sigma}', \boldsymbol{\Sigma}'] \\ &= \boldsymbol{\sigma}' \cdot \mathbf{A}\boldsymbol{\sigma}' = \mathbf{A}[\boldsymbol{\sigma}', \boldsymbol{\sigma}'] \quad . \end{aligned} \quad (9.159)$$

Classical, so-called local elasticity or plasticity may be formulated on the basis of \mathbf{E} or \mathbf{A} . Gradient elasticity or gradient plasticity take into account, besides the strain tensor, also so-called curvature tensors (not to be confused with Riemann curvature tensor), which capture the gradient of the deformation gradient tensor. Geometrically, curvature tensors may be introduced as follows. Let $\boldsymbol{\Sigma}'_1, \boldsymbol{\Sigma}'_2$ be tangent vectors to different material lines at \mathbf{X} in R_R , the corresponding tangent vectors at $\mathbf{x} = \boldsymbol{\chi}(\mathbf{X}, t)$ being $\boldsymbol{\sigma}'_1, \boldsymbol{\sigma}'_2$, respectively. Moreover, assume $\boldsymbol{\Xi}(\mathbf{X})$ to be normal to a material surface at \mathbf{X} in R_R , the corresponding normal vector at $\mathbf{x} = \boldsymbol{\chi}(\mathbf{X}, t)$ to the same material surface in R_t being $\boldsymbol{\xi}$,

$$\boldsymbol{\xi}(\mathbf{X}, t) = \mathbf{F}^{T-1}(\mathbf{X}, t)\boldsymbol{\Xi}(\mathbf{X}) \quad . \quad (9.160)$$

A scalar measure Δ_c for the deformation process, accounting for gradients of \mathbf{F} , may be defined e.g. by

$$\Delta_c(\mathbf{X}, t) := \boldsymbol{\xi} \cdot (\nabla_{R_t} \boldsymbol{\sigma}'_1)[\boldsymbol{\sigma}'_2] - \boldsymbol{\Xi} \cdot (\nabla_{R_R} \boldsymbol{\Sigma}'_1)[\boldsymbol{\Sigma}'_2] \quad , \quad (9.161)$$

where

$$\nabla_{R_t} \boldsymbol{\sigma}'_1 := \text{grad} \boldsymbol{\sigma}'_1 \equiv \frac{\partial \boldsymbol{\sigma}'_1}{\partial \mathbf{x}} \equiv \frac{\partial \boldsymbol{\sigma}'_1}{\partial X^i} \otimes \mathbf{g}^i \quad , \quad (9.162)$$

$$\nabla_{R_R} \boldsymbol{\Sigma}'_1 := \text{GRAD} \boldsymbol{\Sigma}'_1 \equiv \frac{\partial \boldsymbol{\Sigma}'_1}{\partial \mathbf{X}} \equiv \frac{\partial \boldsymbol{\Sigma}'_1}{\partial X^i} \otimes \mathbf{E}^i \quad , \quad (9.163)$$

and $\mathbf{g}_i, \mathbf{g}^i$ as given by Eqs. (9.57), (9.59). Since

$$\mathbf{g}^i \cdot \boldsymbol{\sigma}'_2 = \mathbf{E}^i \cdot \boldsymbol{\Sigma}'_2 \quad , \quad (9.164)$$

and

$$\begin{aligned} \boldsymbol{\xi} \cdot (\nabla_{R_t} \boldsymbol{\sigma}'_1)[\boldsymbol{\sigma}'_2] &= \boldsymbol{\Xi} \cdot \mathbf{F}^{-1} \left(\mathbf{F} \frac{\partial \boldsymbol{\Sigma}'_1}{\partial X^i} + \frac{\partial \mathbf{F}}{\partial X^i} \boldsymbol{\Sigma}'_1 \right) (\mathbf{g}^i \cdot \boldsymbol{\sigma}'_2) \\ &= \left(\boldsymbol{\Xi} \cdot \frac{\partial \boldsymbol{\Sigma}'_1}{\partial X^i} \right) (\mathbf{E}^i \cdot \boldsymbol{\Sigma}'_2) + \boldsymbol{\Xi} \cdot \left(\mathbf{F}^{-1} \frac{\partial \mathbf{F}}{\partial X^i} \boldsymbol{\Sigma}'_1 \right) (\mathbf{E}^i \cdot \boldsymbol{\Sigma}'_2) \end{aligned} \quad (9.165)$$

we conclude from Eq. (9.161) that

$$\Delta_c = \Xi \cdot \left(\mathbf{F}^{-1} \frac{\partial \mathbf{F}}{\partial X^i} \Sigma'_1 \right) (\mathbf{E}^i \cdot \Sigma'_2) = \xi \cdot \left(\frac{\partial \mathbf{F}}{\partial X^i} \mathbf{F}^{-1} \sigma'_1 \right) (\mathbf{g}^i \cdot \sigma'_2) \quad , \quad (9.166)$$

or equivalently (cf. Eq. (9.13))

$$\Delta_c = \left(\mathbf{F}^{-1} \frac{\partial \mathbf{F}}{\partial X^i} \otimes \mathbf{E}^i \right) [\Xi, \Sigma'_1, \Sigma'_2] = \left(\frac{\partial \mathbf{F}}{\partial X^i} \mathbf{F}^{-1} \otimes \mathbf{g}^i \right) [\xi, \sigma'_1, \sigma'_2] \quad . \quad (9.167)$$

On defining so-called curvature tensors (cf. Eq. (9.9))

$$\tilde{\mathcal{K}} := \mathbf{F}^{-1} \frac{\partial \mathbf{F}}{\partial X^i} \otimes \mathbf{E}^i = \mathbf{F}^{-1} \text{GRAD} \mathbf{F} = -(\text{GRAD} \mathbf{F}^{-1}) \diamond \mathbf{F} \quad , \quad (9.168)$$

$$\mathcal{K} := \frac{\partial \mathbf{F}}{\partial X^i} \mathbf{F}^{-1} \otimes \mathbf{g}^i = (\text{grad} \mathbf{F}) \diamond \mathbf{F}^{-1} = -\mathbf{F} \text{grad} \mathbf{F}^{-1} \quad , \quad (9.169)$$

we arrive at the form-invariant expression

$$\Delta_c = \tilde{\mathcal{K}}[\Xi, \Sigma'_1, \Sigma'_2] = \mathcal{K}[\xi, \sigma'_1, \sigma'_2] \quad (9.170)$$

with (cf. Eq. (9.15))

$$\tilde{\mathcal{K}} = \mathcal{L}(\mathbf{F}^{-1}, \mathbf{F}^T, \mathbf{F}^T)[\mathcal{K}] \quad \text{or} \quad \mathcal{K} = \mathcal{L}(\mathbf{F}, \mathbf{F}^{T-1}, \mathbf{F}^{T-1})[\tilde{\mathcal{K}}] \quad . \quad (9.171)$$

$\tilde{\mathcal{K}}$ and \mathcal{K} are regarded as appropriate candidate for curvature tensors to be used in constitutive theories.

9.8.1.2 Decomposition of deformation into elastic and plastic parts

As in classical plasticity, it is assumed that the deformation gradient tensor \mathbf{F} may be decomposed into elastic and plastic parts according to

$$\mathbf{F} = \mathbf{F}_e \mathbf{F}_p \quad . \quad (9.172)$$

This decomposition of \mathbf{F} has been broadly known by the works of Lee and Liu [101] and Lee [100]. It is assumed that (9.172) is unique except for a rigid body rotation (see Casey and Naghdi [13, 14]). In opposite to $\mathbf{F}(\mathbf{X}, t)$, $\mathbf{F}_p(\mathbf{X}, t)$ (and therefore $\mathbf{F}_e(\mathbf{X}, t)$ too) is incompatible deformation. For fixed time t , $\mathbf{F}_p(\mathbf{X}, t)$ induces a local configuration at \mathbf{X} . Let $\hat{\mathbf{x}} \in \mathcal{E}$ be the position vector of the material point in that local configuration, which in the reference configuration posses the position \mathbf{X} . Obviously, the position $\hat{\mathbf{x}}$ can be chosen arbitrarily. This fact may be visualized by imaging the local configuration induced by $\mathbf{F}_p(\mathbf{X}, t)$ at \mathbf{X} to map a neighbourhood $\mathcal{N}(\mathbf{X}) \in \mathcal{E}$ on a neighbourhood $\hat{\mathcal{M}}(\hat{\mathbf{x}}, t) \in \mathcal{E}$ around $\hat{\mathbf{x}}$, with $\hat{\mathbf{x}}$ being arbitrary. The same is possible by tearing material points along a material line passing through \mathbf{X} , apart from the body. It should then be clear, that the image of that material line under \mathbf{F}_p will be unique apart from a rigid body motion. Now, as $\hat{\mathbf{x}}$ may be chosen arbitrary, we assume in particular $\hat{\mathbf{x}}$ to be given by an arbitrary deformation $\hat{\chi}$,

$$\hat{\mathbf{x}} = \hat{\chi}(\mathbf{X}, t) \quad . \quad (9.173)$$

It is emphasized that $\hat{\chi}$ is not a real deformation, as well as $\mathbf{F}_p(\mathbf{X}, t) \neq \frac{\partial \hat{\chi}}{\partial \mathbf{X}}$ generally. As special cases, $\hat{\mathbf{x}} \equiv \mathbf{X}$ and $\hat{\mathbf{x}} \equiv \mathbf{x}$ are allowed. In the following, the fictitious configuration introduced by

deformation $\hat{\chi}(\cdot, t)$ is left arbitrary and referred to as plastic intermediate configuration. We write \hat{R}_t for the range in \mathcal{E} occupied by the body under the configuration induced by $\hat{\chi}$, $\hat{R}_t = \hat{\chi}(R_R, t)$. Also, it suffices to regard \mathbf{F}_p to be a local deformation as discussed in Sects. 9.5 and 9.8.1. Thus, for fixed t and given neighbourhood $\mathcal{N}(\mathbf{X}) \in \mathcal{E}$, $\mathbf{X} \in R_R$, there exists a deformation $\hat{\mu}_{\mathbf{X}}(\cdot, t)$ on $\mathcal{N}(\mathbf{X})$, which maps $\mathcal{N}(\mathbf{X})$ on the neighbourhood $\hat{\mathcal{M}}(\hat{\mathbf{x}}, t) \subset \mathcal{E}$, $\hat{\mathbf{x}} = \hat{\chi}(\mathbf{X}, t) \in \hat{R}_t$, with

$$\hat{\mu}_{\mathbf{X}} : \mathcal{N}(\mathbf{X}) \times I \rightarrow \hat{\mathcal{M}}(\hat{\mathbf{x}}, t) := \hat{\mu}_{\mathbf{X}}(\mathcal{N}(\mathbf{X}), t) \quad , \quad (9.174)$$

$$\hat{\mu}_{\mathbf{X}}(\mathbf{X}, t) = \hat{\mathbf{x}} = \hat{\chi}(\mathbf{X}, t) \quad , \quad (9.175)$$

$$\left. \frac{\partial \hat{\mu}_{\mathbf{X}}(\mathbf{Y}, t)}{\partial \mathbf{Y}} \right|_{\mathbf{Y}=\mathbf{X}} = \mathbf{F}_p(\mathbf{X}, t) = (\mathbf{F}_p)^i_j \hat{\mathbf{e}}_i \otimes \mathbf{E}^j \quad . \quad (9.176)$$

In Eq. (9.176), $\{\hat{\mathbf{e}}_i\}$ is coordinate basis to a Cartesian coordinate system $\{\hat{x}_i\}$, so that $\hat{\mathbf{x}} = \hat{x}^i \hat{\mathbf{e}}_i$. Evidently, every material line or material surface in $\mathcal{N}(\mathbf{X}) \subset R_R$, passing through \mathbf{X} , will be mapped under $\hat{\mu}_{\mathbf{X}}$ respectively to a "material line" or "material surface" in $\hat{\mathcal{M}}(\hat{\mathbf{x}}, t) \in \mathcal{E}$, passing through $\hat{\mathbf{x}}$.

Let $\boldsymbol{\Sigma}'(\mathbf{X})$ be tangent vector at \mathbf{X} on a material line in $\mathcal{N}(\mathbf{X})$ and $\hat{\boldsymbol{\sigma}}'(\mathbf{X}, t)$ the corresponding tangent vector at $\hat{\mathbf{x}}$ in $\hat{\mathcal{M}}(\hat{\mathbf{x}}, t)$. Then,

$$\hat{\boldsymbol{\sigma}}' = \mathbf{F}_p \boldsymbol{\Sigma}' = \mathbf{F}_p^{-1} \boldsymbol{\sigma}' \quad . \quad (9.177)$$

This suggests additive decomposition of Δ_s in the form

$$\Delta_s = (\Delta_s)_e + (\Delta_s)_p \quad , \quad (9.178)$$

$$(\Delta_s)_e := \frac{1}{2}(\boldsymbol{\sigma}' \cdot \boldsymbol{\sigma}' - \hat{\boldsymbol{\sigma}}' \cdot \hat{\boldsymbol{\sigma}}') \quad , \quad (9.179)$$

$$(\Delta_s)_p := \frac{1}{2}(\hat{\boldsymbol{\sigma}}' \cdot \hat{\boldsymbol{\sigma}}' - \boldsymbol{\Sigma}' \cdot \boldsymbol{\Sigma}') \quad . \quad (9.180)$$

Like Δ_s , the scalar differences $(\Delta_s)_e$ and $(\Delta_s)_p$ can be expressed form-invariantly. For instance, we have relative to R_R ,

$$(\Delta_s)_e = \boldsymbol{\Sigma}' \cdot \mathbf{E}_e \boldsymbol{\Sigma}' \quad , \quad (\Delta_s)_p = \boldsymbol{\Sigma}' \cdot \mathbf{E}_p \boldsymbol{\Sigma}' \quad , \quad (9.181)$$

$$\mathbf{E}_p = \frac{1}{2}(\mathbf{C}_p - \mathbf{1}) \quad , \quad \mathbf{E} = \mathbf{E}_e + \mathbf{E}_p \quad , \quad \mathbf{C}_p = \mathbf{F}_p^T \mathbf{F}_p \quad . \quad (9.182)$$

(Further relations may be found in Haupt and Tsakmakis [81] and Tsakmakis [157].)

On the other hand, let $\boldsymbol{\Xi}(\mathbf{X})$, $\boldsymbol{\Sigma}'_1(\mathbf{X})$, $\boldsymbol{\Sigma}'_2(\mathbf{X})$ be vectors at \mathbf{X} as assumed in Sect. 9.8.1.1, the corresponding vectors at $\hat{\mathbf{x}}$ being given by

$$\hat{\boldsymbol{\xi}} = \mathbf{F}_p^{T-1} \boldsymbol{\Xi} \quad , \quad \hat{\boldsymbol{\sigma}}'_1 = \mathbf{F}_p \boldsymbol{\Sigma}'_1 \quad , \quad \hat{\boldsymbol{\sigma}}'_2 = \mathbf{F}_p \boldsymbol{\Sigma}'_2 \quad . \quad (9.183)$$

Then, following additive decomposition of Δ_c is suggested,

$$\Delta_c = (\Delta_c)_e + (\Delta_c)_p \quad , \quad (9.184)$$

$$(\Delta_c)_e := \hat{\boldsymbol{\xi}} \cdot (\nabla_{R_t} \boldsymbol{\sigma}'_1)[\boldsymbol{\sigma}'_2] - \hat{\boldsymbol{\xi}} \cdot (\nabla_{\hat{R}_t} \hat{\boldsymbol{\sigma}}'_1)[\hat{\boldsymbol{\sigma}}'_2] \quad , \quad (9.185)$$

$$(\Delta_c)_p := \hat{\boldsymbol{\xi}} \cdot (\nabla_{\hat{R}_t} \hat{\boldsymbol{\sigma}}'_1)[\hat{\boldsymbol{\sigma}}'_2] - \boldsymbol{\Xi} \cdot (\nabla_{R_R} \boldsymbol{\Sigma}'_1)[\boldsymbol{\Sigma}'_2] \quad , \quad (9.186)$$

where $\nabla_{\hat{R}_t} \hat{\boldsymbol{\sigma}}'_1$ denotes a relative covariant derivative of $\hat{\boldsymbol{\sigma}}'_1$ (cf. Eq. (9.104))

$$\nabla_{\hat{R}_t} \hat{\boldsymbol{\sigma}}'_1 := \left\{ \frac{\partial (\hat{\boldsymbol{\sigma}}'_1)^j}{\partial X^i} + \Lambda^j_{il} (\hat{\boldsymbol{\sigma}}'_1)^l \right\} \hat{\mathbf{g}}_j \otimes \hat{\mathbf{g}}^i \quad (9.187)$$

with

$$\hat{\mathbf{g}}_i := \mathbf{F}_p \mathbf{E}_i \quad , \quad \hat{\mathbf{g}}^i := \mathbf{F}_p^{T-1} \mathbf{E}^i \quad , \quad \hat{\boldsymbol{\sigma}}'_1 = (\hat{\boldsymbol{\sigma}}'_1)^j \hat{\mathbf{g}}_j \quad . \quad (9.188)$$

If the real motion of the material is considered, then both R_R and R_t are regarded as Euclidean manifolds. Thus, it is natural to use gradient operators in Eqs. (9.162) and (9.163) as appropriate covariant derivatives for these manifolds. However, the essential issues of the plastic intermediate configuration are generated by local deformations \mathbf{F}_p , and therefore the appropriate spatial differential operator for \hat{R}_t is regarded to be the relative covariant derivative (9.187). It is important to remark, that, with respect to $\{\mathbf{E}_i\}$, the gradient $\nabla_{R_R} \boldsymbol{\Sigma}'_1$ obeys the representation

$$\nabla_{R_R} \boldsymbol{\Sigma}'_1 = \left\{ \frac{\partial(\boldsymbol{\Sigma}'_1)^j}{\partial X^i} + \lambda^j_{il}(\boldsymbol{\Sigma}'_1)^l \right\} \mathbf{E}_j \otimes \mathbf{E}^i \quad , \quad (9.189)$$

where

$$\boldsymbol{\Sigma}'_1 = (\boldsymbol{\Sigma}'_1)^i \mathbf{E}_i \quad , \quad (\boldsymbol{\Sigma}'_1)^i = (\boldsymbol{\sigma}'_1)^i = (\hat{\boldsymbol{\sigma}}'_1)^i \quad . \quad (9.190)$$

In Eq. (9.189), λ^j_{il} are the symbols, relative to $\{\mathbf{E}_i\}$, of the Levi-Civita connection in R_R (see Sect. 9.10). As $\{\mathbf{E}_i\}$ is a Cartesian coordinate basis, $\lambda^j_{il} = 0$. However, with respect to another basis the symbols of the Levi-Civita connection will be not vanishing.

Now,

$$\hat{\boldsymbol{\xi}} \cdot (\nabla_{\hat{R}_t} \hat{\boldsymbol{\sigma}}'_1)[\hat{\boldsymbol{\sigma}}'_2] = \boldsymbol{\Xi} \cdot \left\{ \frac{\partial(\boldsymbol{\Sigma}'_1)^j}{\partial X^i} + \Lambda^j_{il}(\boldsymbol{\Sigma}'_1)^l \right\} (\mathbf{E}_j \otimes \mathbf{E}^i)[\boldsymbol{\Sigma}'_2] \quad , \quad (9.191)$$

so that, after substituting in Eq. (9.186),

$$(\Delta_c)_p = \tilde{\mathcal{K}}[\boldsymbol{\Xi}, \boldsymbol{\Sigma}'_1, \boldsymbol{\Sigma}'_2] \quad (9.192)$$

with

$$\tilde{\mathcal{K}}_p := (\Lambda^j_{il} - \lambda^j_{il}) \mathbf{E}_j \otimes \mathbf{E}^l \otimes \mathbf{E}^i \quad . \quad (9.193)$$

Quantities $(\tilde{\mathcal{K}}_p)^j_{li}$ are given as difference of connection symbols (irrespective of the property $\lambda^j_{il} = 0$ relative to $\{\mathbf{E}_i\}$),

$$(\tilde{\mathcal{K}}_p)^j_{li} = (\Lambda^j_{il} - \lambda^j_{il}) \quad (9.194)$$

and hence are components of a third-order tensor. Quite similar, one may prove, that the components of \mathcal{K} are given also as difference of connection symbols.

It is straightforward to show, that

$$(\Delta_c)_e = \tilde{\mathcal{K}}_e[\boldsymbol{\Xi}, \boldsymbol{\Sigma}'_1, \boldsymbol{\Sigma}'_2] \quad (9.195)$$

with

$$\tilde{\mathcal{K}} = \tilde{\mathcal{K}}_e + \tilde{\mathcal{K}}_p \quad . \quad (9.196)$$

Moreover, it can be seen that $(\Delta_c)_p$ and $(\Delta_c)_e$ can be expressed form-invariantly relative to \hat{R}_t or R_t . For instance, relative to \hat{R}_t , $(\Delta_c)_p$ obeys the representation

$$(\Delta_c)_p = \hat{\mathcal{K}}_p[\hat{\boldsymbol{\xi}}, \hat{\boldsymbol{\sigma}}'_1, \hat{\boldsymbol{\sigma}}'_2] \quad (9.197)$$

with (cf. Eq. (9.171))

$$\tilde{\mathcal{K}}_p = \mathcal{L}(\mathbf{F}_p^{-1}, \mathbf{F}_p^T, \mathbf{F}_p^T)[\hat{\mathcal{K}}_p] \quad \text{or} \quad \hat{\mathcal{K}}_p = \mathcal{L}(\mathbf{F}_p, \mathbf{F}_p^{T-1}, \mathbf{F}_p^{T-1})[\tilde{\mathcal{K}}_p] \quad , \quad (9.198)$$

and so on.

This way, various so-called curvature tensors, like $\tilde{\mathcal{K}}$, $\tilde{\mathcal{K}}_e$, $\tilde{\mathcal{K}}_p$, may be introduced, which capture gradient effects. They are third-order tensors and can be used to formulate constitutive theories. Here, we have gained such tensors on the basis of the form-invariance of scalar differences. Associated time derivatives to the strain and curvature tensors can be assigned by requiring from the time derivatives $(\Delta_s)^\cdot$, $(\Delta_s)_e^\cdot$, $(\Delta_s)_p^\cdot$, $(\Delta_s)^\ddot{\cdot}$, \dots , $(\Delta_c)^\cdot$, $(\Delta_c)_e^\cdot$, $(\Delta_c)_p^\cdot$, $(\Delta_c)^\ddot{\cdot}$, \dots , to be form-invariant too. For $(\Delta_s)^\cdot$, $(\Delta_s)_e^\cdot$, $(\Delta_s)_p^\cdot$, this is demonstrated in Haupt and Tsakmakis [81] and Tsakmakis [157].

9.8.1.3 The special case $\Lambda_{il}^j = (\mathbf{F}_p^{-1})_n^j \frac{\partial (\mathbf{F}_p)_l^n}{\partial X^i}$

Assume the relative covariant derivative $\nabla_{\hat{R}_i}$ to be given as a relative gradient operator, with (cf. Eq. (9.79))

$$\Lambda_{il}^j = (\mathbf{F}_p^{-1})_n^j \frac{\partial (\mathbf{F}_p)_l^n}{\partial X^i} \quad . \quad (9.199)$$

Then, relative to $\{\mathbf{E}_i\}$,

$$(\tilde{\mathcal{K}}_p)_{li}^j = (\mathbf{F}_p^{-1})_n^j \frac{\partial (\mathbf{F}_p)_l^n}{\partial X^i} - \lambda_{li}^j \quad . \quad (9.200)$$

Moreover, it can be verified that,

$$\tilde{\mathcal{K}}_p = \mathbf{F}_p^{-1} \text{GRAD} \mathbf{F}_p \quad . \quad (9.201)$$

A general crystal plasticity theory, based on $\tilde{\mathcal{K}}_p$ defined in Eq. (9.201), has been proposed by Le and Stumpf [98, 99]. The discussion in Sect. 9.7.1 makes clear that the connection defined by (9.199) is non-symmetric and metric, the metric being given by (cf. Eq. (9.100))

$$\tilde{\mathbf{G}}(\mathbf{A}, \mathbf{B}) = \mathbf{A} \cdot \mathbf{F}_p^T \mathbf{F}_p \mathbf{B} \quad . \quad (9.202)$$

The space characterized by the connection defined in Eq. (9.199) is flat and therefore preserves teleparallelism.

There are crystal plasticity theories, in which $\tilde{\mathcal{K}}_p$ enters into the constitutive functions in terms of a dislocation density tensor. Following e.g. Cermelli and Gurtin [16], a "geometric dislocation tensor" \mathbf{G}_R may be defined relative to R_R by

$$\mathbf{G}_R := (\text{CURL} \mathbf{F}_p) \mathbf{F}_p^{T-1} \quad , \quad (9.203)$$

where the CURL of a second-order tensor is defined as in Cermelli and Gurtin [16]. It can be shown, that

$$\mathbf{G}_R^T = e^{ijl} (\tilde{\mathcal{K}}_p)_{lj}^k \mathbf{E}_k \otimes \mathbf{E}_i \quad (9.204)$$

with $e^{ijl} \equiv e_{ijl}$ denoting the alternating symbol. Consequently, \mathbf{G}_R may be expressed as a function of $\tilde{\mathcal{K}}_p$. It has been verified (see e.g. Le and Stumpf [98]), that \mathbf{G}_R is related to the torsion of the connection for R_R defined by Eq. (9.199). Constitutive theories for gradient crystal plasticity on the basis of \mathbf{G}_R have been proposed e.g. by Le and Stumpf [99, 98] and Gurtin [79, 80].

9.8.2 Micropolar continua

Microphysically, real materials like metals indicate some kind of patterning with discrete distributed mass. Therefore, when formulating the constitutive properties of a material point, not only the material point itself, but rather an entire neighbourhood of the point should be taken into account. In the framework of continuum mechanics, this may be realized by attaching to each material point of the macroscopic continuum a microcontinuum (microstructure), which serves to model microphysical (microstructural) properties of the overall material body (see Fig. 9.2). The introduction of such microcontinua into the theory goes back to Mindlin [122]. Here, the microcontinuum is supposed to be, in some sense, mechanically (we are dealing with isothermal processes and uniform distributed temperature only) equivalent to some patterned material neighbourhood around the considered point. The mass in the microcontinuum is assumed to be continuously distributed. All together, the microcontinuum is generally a fictitious (conceptual) one, which may have arbitrary finite dimensions, i.e. the region in \mathcal{E} occupied by the microcontinuum at a material point of the macroscopic material must not necessarily be subset of the region occupied by the macroscopic material itself (see also Grammenoudis and Tsakmakis [71], where this kind of microcontinuum has been invoked in a micropolar plasticity theory). Following Eringen (see e.g. [46]), we define a micropolar material to be a material body with a microcontinuum at each point, which behaves like a rigid body. In what follows, we shall survey the fundamental kinematical concepts addressing micropolar continua, and we shall establish geometrically appropriate micropolar strain and curvature tensors, to be used in constitutive theories, by employing relative covariant derivatives.

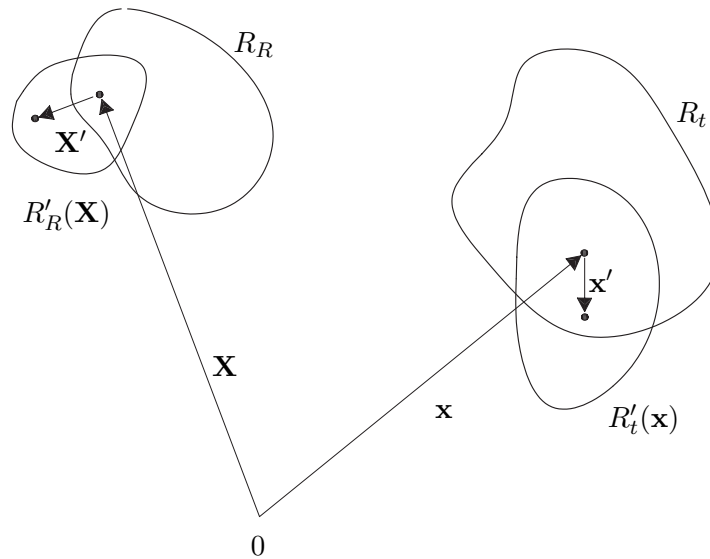

Figure 9.2: The region $\mathcal{R}'_{\mathcal{R}}(\mathbf{X})$ (respectively $\mathcal{R}'_t(\mathbf{x})$) must not necessarily be subset of the region $\mathcal{R}_{\mathcal{R}}$ (respectively \mathcal{R}_t).

9.8.2.1 Deformation

We extend the classical continuum reviewed in Sect. 9.4 by attaching to every material point $\mathcal{X} \in \mathcal{B}$ a material body (microcontinuum) \mathcal{B}' . Note that the macrocontinuum here is the same as the overall

material in Mindlin's theory [122] and is in general different than the macromaterial there. Furthermore, the same body $\mathcal{B}'(\mathcal{X}) \equiv \mathcal{B}'$, with elements $\mathcal{X}', \mathcal{Y}', \dots$, is attached at every \mathcal{X} . Both, the macroscopic and the microscopic material bodies are mapped on $\mathcal{E} \times \mathcal{E}$, through a function (χ_R, χ'_R) , referred to as reference configuration,

$$(\mathcal{X}, \mathcal{X}') \mapsto \begin{pmatrix} \mathbf{X} = \chi_R(\mathcal{X}) \\ \mathbf{X}' = \chi'_R(\mathcal{X}, \mathcal{X}') \end{pmatrix} . \quad (9.205)$$

The position vector \mathbf{X}' is defined to emanate from point $\mathbf{X} \in \mathcal{E}$ and to lead to the point in space occupied by \mathcal{X}' . An actual or current configuration at time t is a pair of functions (χ_t, χ'_t) with

$$(\mathcal{X}, \mathcal{X}') \mapsto \begin{pmatrix} \mathbf{x} = \chi_t(\mathcal{X}) \\ \mathbf{x}' = \chi'_t(\mathcal{X}, \mathcal{X}') \end{pmatrix} . \quad (9.206)$$

Here, \mathbf{x}' is defined to be the vector assign to the pair $(\mathcal{X}, \mathcal{X}')$ at time t . In the following we shall refer to the ranges $R_R := \chi_R(\mathcal{B})$, $R'_R(\mathbf{X}) := \chi'_R(\mathcal{X}, \mathcal{B})$, $R_t := \chi_t(\mathcal{B})$, $R'_t(\mathbf{x}) := \chi'_t(\mathcal{X}, \mathcal{B})$, which are assumed to be open subsets of \mathcal{E} . As usually, the maps defined by (9.205) and (9.206), from $\mathcal{B} \times \mathcal{B}'$ on $\mathcal{E} \times \mathcal{E}$, are assumed to be invertible. An one parameter family of configurations (χ, χ') , parameterized with time $t \in I$, is called motion of the micropolar continuum,

$$(\mathcal{X}, \mathcal{X}', t) \mapsto \begin{pmatrix} \mathbf{x} = \chi(\mathcal{X}, t) \\ \mathbf{x}' = \chi'(\mathcal{X}, \mathcal{X}', t) \end{pmatrix} . \quad (9.207)$$

We assume the initial configuration at time t_0 to coincide with the reference configuration. Since the inverse functions of χ, χ' , for fixed time t , are assumed to exist, the motion can be expressed in terms of \mathbf{X}, \mathbf{X}' . If no confusion may arise, following common praxis, we shall use the same symbols for these functions as in Eq. (9.207),

$$(\mathbf{X}, \mathbf{X}', t) \mapsto \begin{pmatrix} \mathbf{x} = \chi(\mathbf{X}, t) \\ \mathbf{x}' = \chi'(\mathbf{X}, \mathbf{X}', t) \end{pmatrix} . \quad (9.208)$$

Functions (χ, χ') in Eq. (9.208), for fixed time t , are referred to as deformation from the reference to the actual configuration. While the deformation χ of the macrocontinuum is characterized, as before, by the macroscopic deformation gradient tensor $\mathbf{F} = \frac{\partial \chi}{\partial \mathbf{X}}$, the deformation χ' of the microcontinuum is characterized by the microscopic deformation gradient tensor

$$\bar{\mathbf{R}}(\mathbf{X}, t) = \frac{\partial \chi'}{\partial \mathbf{X}'} , \quad \bar{\mathbf{R}}^T = \bar{\mathbf{R}}^{-1} , \quad \det \bar{\mathbf{R}} = 1 . \quad (9.209)$$

These equations account for the property that the microcontinuum suffers rigid body motions, so that $\bar{\mathbf{R}}$ describes a so-called micropolar rotation. Note, that \mathbf{F} and $\bar{\mathbf{R}}$ should be understood to be the linear parts of the corresponding two point tensor maps. Because $\bar{\mathbf{R}}(\mathbf{X}, t)$ is a homogeneous deformation in regard to $R'_R(\mathbf{X})$, we may view $\bar{\mathbf{R}}(\mathbf{X}, t)$ as being a map from $T_{\mathbf{X}}R'_R(\mathbf{X})$ on $T_{\mathbf{x}}R'_t(\mathbf{x})$. In particular,

$$\bar{\mathbf{R}}(\mathbf{X}, t) : T_{\mathbf{X}}R'_R(\mathbf{X}) \equiv T_{\mathbf{X}}R_R(\mathbf{X}) \rightarrow T_{\mathbf{x}}R'_t(\mathbf{x}) \equiv T_{\mathbf{x}}R_t(\mathbf{x}) , \quad (9.210)$$

from which use is made in what follows. Eq. (9.210) states that $\bar{\mathbf{R}}$ can be treated as a two-point tensor field like \mathbf{F} . Also, and this is very important, $\bar{\mathbf{R}}$ is an incompatible deformation field with respect to the macroscopic continuum.

The kinematics of micropolar continua may be based on multiplicative decompositions (cf. Eringen and Kafadar [48] or Steinmann [149])

$$\mathbf{F} = \bar{\mathbf{R}}\bar{\mathbf{U}} = \bar{\mathbf{V}}\bar{\mathbf{R}} \quad (9.211)$$

of \mathbf{F} . Unlike tensors \mathbf{U} , \mathbf{V} in the polar decomposition of \mathbf{F} (see Eq. (9.37)), the tensors $\bar{\mathbf{U}}$, $\bar{\mathbf{V}}$ are not symmetric. Since \mathbf{F} , $\bar{\mathbf{R}}$ are two-point tensors, $\bar{\mathbf{U}}(\mathbf{X}, t)$ and $\bar{\mathbf{V}}(\mathbf{X}, t)$ are endomorphisms respectively from $T_{\mathbf{X}}R_R$ to $T_{\mathbf{X}}R_R$ and from $T_{\mathbf{x}}R_t$ to $T_{\mathbf{x}}R_t$. The deformation function can be specified further by describing the rigid body rotation of the microscopic body by means of the motion of three material points \mathcal{X}'_i , $i = 1, 2, 3$. A unique description of the motion arises whenever the points \mathcal{X}'_i are mutually different, not all in a plane, and are different than \mathcal{X} . Let $\Phi_i \equiv \mathbf{X}'_i$ be the (position) vectors assigned to the pairs $(\mathcal{X}, \mathcal{X}'_i)$ at time t_0 , respectively. All what says the map in Eq. (9.205) may be reflected by the map

$$(\mathcal{X}, \mathcal{X}'_i) \mapsto \left(\begin{array}{l} \mathbf{X} = \chi_R(\mathcal{X}) \\ \Phi_i = \chi'_R(\mathcal{X}, \mathcal{X}'_i) \end{array} \right) . \quad (9.212)$$

At time t , the (position) vectors emanating from $\mathbf{x} \in \mathcal{E}$ and leading to the places occupied by \mathcal{X}'_i are denoted by φ_i ,

$$\varphi_i = \varphi_i(\mathbf{X}, \Phi_i, t) = \bar{\mathbf{R}}(\mathbf{X}, t)\Phi_i . \quad (9.213)$$

Consequently, the deformation (9.208) can be expressed alternatively and equivalently in terms of

$$(\mathbf{X}, \Phi_i, t) \mapsto \left(\begin{array}{l} \mathbf{x} = \chi(\mathbf{X}, t) \\ \varphi_i = \bar{\mathbf{R}}(\mathbf{X}, t)\Phi_i \end{array} \right) , \quad (9.214)$$

which is tacitly the starting point of most micropolar theories.

Next, we assume Φ_i to be given as field $\Phi_i(\mathbf{X})$. Then, the deformation from the reference to the actual configuration will be expressible as

$$(\mathbf{X}, t) \mapsto \left(\begin{array}{l} \mathbf{x} = \chi(\mathbf{X}, t) \\ \varphi_i(\mathbf{x}, t) = \bar{\mathbf{R}}(\mathbf{X}, t)\Phi_i(\mathbf{X}) \end{array} \right) . \quad (9.215)$$

This is the map for the motion of the micropolar continuum we deal with in this paper.

In the remainder we shall introduce some scalar differences, in order to gain micropolar strain and curvature tensors, by requiring from them to be form-invariant with respect to the chosen configuration.

9.8.2.2 Micropolar strain and curvature tensors

Let $\Sigma'(\mathbf{X})$ be tangent vector at a material line at \mathbf{X} , the corresponding tangent vector at $\mathbf{x} = \chi(\mathbf{X}, t)$ being $\sigma'(\mathbf{x}, t)$. Assume $\Phi(\mathbf{X})$ to be a vector at \mathbf{X} , which is position vector for some material point \mathcal{X}' , the corresponding vector at \mathbf{x} being $\varphi(\mathbf{x}, t)$,

$$\sigma' = \mathbf{F}\Sigma' \quad , \quad \varphi = \bar{\mathbf{R}}\Phi . \quad (9.216)$$

We define a scalar difference Δ_s by

$$\Delta_s(\mathbf{X}, t) := \varphi \cdot \sigma' - \Phi \cdot \Sigma' \quad , \quad (9.217)$$

as a measure accounting for the geometry of deformation of the micropolar continuum (Diebels and Ehlers [34], Volk [163] and Grammenoudis and Tsakmakis [67]). It can readily be seen, that

$$\Delta_s = \Phi \cdot (\bar{\mathbf{R}}^T \mathbf{F} - \mathbf{1})\Sigma' = \Phi \cdot (\bar{\mathbf{U}} - \mathbf{1})\Sigma'$$

$$= \boldsymbol{\varphi} \cdot (\mathbf{1} - \bar{\mathbf{R}}\mathbf{F}^{-1})\boldsymbol{\sigma}' = \boldsymbol{\varphi} \cdot (\mathbf{1} - \bar{\mathbf{V}}^{-1})\boldsymbol{\sigma}' \quad , \quad (9.218)$$

or

$$\Delta_s = \boldsymbol{\Phi} \cdot \tilde{\boldsymbol{\epsilon}}\boldsymbol{\Sigma}' = \boldsymbol{\varphi} \cdot \boldsymbol{\epsilon}\boldsymbol{\sigma}' \quad , \quad (9.219)$$

where

$$\tilde{\boldsymbol{\epsilon}} := \bar{\mathbf{U}} - \mathbf{1} \quad , \quad \boldsymbol{\epsilon} := \mathbf{1} - \bar{\mathbf{V}}^{-1} \quad (9.220)$$

are micropolar strain tensors, which operate in tangent spaces of R_R and R_t , respectively. It can be recognized from Eq. (9.219), that Δ_s is expressed in a form-invariant manner with respect to R_R and R_t . On requiring form-invariance of Δ_s relative to other configurations (local or global), further micropolar strains may be introduced.

Proceeding to obtain micropolar curvature tensors, we define a scalar difference Δ_c by

$$\Delta_c(\mathbf{X}, t) := \boldsymbol{\varphi}_1 \cdot (\nabla_{R_t}\boldsymbol{\varphi}_2)[\boldsymbol{\varphi}_3] - \boldsymbol{\Phi}_1 \cdot (\nabla_{R_R}\boldsymbol{\Phi}_2)[\boldsymbol{\Phi}_3] \quad , \quad (9.221)$$

where $\boldsymbol{\Phi}_i$, $\boldsymbol{\varphi}_i$ are defined in Eq. (9.213). Several classes of curvature tensors may be obtained in dependence on the definition for the space derivatives in formula (9.221). Here, we concentrate ourself on the particular case, considered in Grammenoudis and Tsakmakis [67], where ∇_{R_t} is a relative gradient,

$$\nabla_{R_t}\boldsymbol{\varphi}_2 := (\text{GRAD}\boldsymbol{\varphi}_2)\bar{\mathbf{R}}^T = \frac{\partial\boldsymbol{\varphi}_2}{\partial X^i} \otimes \bar{\mathbf{g}}^i \quad , \quad (9.222)$$

$$\bar{\mathbf{g}}^i := \bar{\mathbf{R}}\mathbf{E}^i \quad , \quad \bar{\mathbf{g}}^i = \bar{\mathbf{R}}\mathbf{E}^i \quad , \quad (9.223)$$

and ∇_{R_R} is a gradient,

$$\nabla_{R_R}\boldsymbol{\Phi}_2 := \text{GRAD}\boldsymbol{\Phi}_2 \quad . \quad (9.224)$$

Because of

$$\bar{\mathbf{g}}^i \cdot \boldsymbol{\varphi}_2 = \mathbf{E}^i \cdot \boldsymbol{\Phi}_2 \quad , \quad (9.225)$$

and

$$\begin{aligned} \boldsymbol{\varphi}_1 \cdot (\nabla_{R_t}\boldsymbol{\varphi}_2)[\boldsymbol{\varphi}_3] &= \boldsymbol{\Phi}_1 \cdot \bar{\mathbf{R}}^T \left(\bar{\mathbf{R}} \frac{\partial\boldsymbol{\Phi}_2}{\partial X^i} + \frac{\partial\bar{\mathbf{R}}}{\partial X^i} \boldsymbol{\Phi}_2 \right) (\bar{\mathbf{g}}^i \cdot \boldsymbol{\varphi}_3) \\ &= \boldsymbol{\Phi}_1 \cdot \frac{\partial\boldsymbol{\Phi}_2}{\partial X^i} (\mathbf{E}^i \cdot \boldsymbol{\Phi}_3) + \boldsymbol{\Phi}_1 \cdot \left(\bar{\mathbf{R}}^T \frac{\partial\bar{\mathbf{R}}}{\partial X^i} \boldsymbol{\Phi}_2 \right) (\mathbf{E}^i \cdot \boldsymbol{\Phi}_3) \quad , \end{aligned} \quad (9.226)$$

it follows from Eq. (9.221), that

$$\Delta_c = \boldsymbol{\Phi}_1 \cdot \left(\bar{\mathbf{R}}^T \frac{\partial\bar{\mathbf{R}}}{\partial X^i} \boldsymbol{\Phi}_2 \right) (\mathbf{E}^i \cdot \boldsymbol{\Phi}_3) = \boldsymbol{\varphi}_1 \cdot \left(\frac{\partial\bar{\mathbf{R}}}{\partial X^i} \bar{\mathbf{R}}^T \boldsymbol{\varphi}_2 \right) (\bar{\mathbf{g}}^i \cdot \boldsymbol{\varphi}_3) \quad , \quad (9.227)$$

and therefore

$$\Delta_c = \left(\bar{\mathbf{R}}^T \frac{\partial\bar{\mathbf{R}}}{\partial X^i} \otimes \mathbf{E}^i \right) [\boldsymbol{\Phi}_1, \boldsymbol{\Phi}_2, \boldsymbol{\Phi}_3] = \left(\frac{\partial\bar{\mathbf{R}}}{\partial X^i} \bar{\mathbf{R}}^T \otimes \bar{\mathbf{g}}^i \right) [\boldsymbol{\varphi}_1, \boldsymbol{\varphi}_2, \boldsymbol{\varphi}_3] \quad . \quad (9.228)$$

We define micropolar curvature tensors $\tilde{\mathcal{K}}$, \mathcal{K} by

$$\tilde{\mathcal{K}} := \bar{\mathbf{R}}^T \frac{\partial \bar{\mathbf{R}}}{\partial X^i} \otimes \mathbf{E}^i = \bar{\mathbf{R}}^T \text{GRAD} \bar{\mathbf{R}} \quad , \quad (9.229)$$

$$\mathcal{K} := \frac{\partial \bar{\mathbf{R}}}{\partial X^i} \bar{\mathbf{R}}^T \otimes \bar{\mathbf{g}}^i = (\nabla_{R_t} \bar{\mathbf{R}}) \diamond \bar{\mathbf{R}}^T \quad . \quad (9.230)$$

Hence

$$\Delta_c = \tilde{\mathcal{K}}[\Phi_1, \Phi_2, \Phi_3] = \mathcal{K}[\varphi_1, \varphi_2, \varphi_3] \quad (9.231)$$

with

$$\tilde{\mathcal{K}} = \mathcal{L}(\bar{\mathbf{R}}^T)[\mathcal{K}] \quad \text{or} \quad \mathcal{K} = \mathcal{L}(\bar{\mathbf{R}})[\tilde{\mathcal{K}}] \quad . \quad (9.232)$$

Eq. (9.231) makes clear that Δ_c can be represented form-invariantly by means of curvature tensors, like $\tilde{\mathcal{K}}$ and \mathcal{K} . These curvature tensors together with the strain tensors $\tilde{\boldsymbol{\epsilon}}$, $\boldsymbol{\epsilon}$, have been assumed as micropolar kinematical variables in the plasticity theory proposed by Grammenoudis and Tsakmakis [67].

Curvature tensor $\tilde{\mathcal{K}}$ exhibits a skew-symmetry property, which may be elaborated by using the component expressions

$$\bar{\mathbf{R}} = \bar{R}_n^m \mathbf{e}_m \otimes \mathbf{E}^n \quad , \quad \bar{\mathbf{R}}^T = (\bar{\mathbf{R}}^T)^m_n \mathbf{E}_m \otimes \mathbf{e}^n = \bar{R}_n^m \mathbf{E}^n \otimes \mathbf{e}^m \quad . \quad (9.233)$$

Since $\{\mathbf{E}_i\}$ is orthonormal basis, δ^{ij} and δ_{ij} may be utilized to raise and lower indices. Invoking Eq. (9.233) in Eq. (9.229),

$$\tilde{\mathcal{K}} = (\tilde{\mathcal{K}})_{mni} \mathbf{E}^m \otimes \mathbf{E}^n \otimes \mathbf{E}^i \quad (9.234)$$

with

$$(\tilde{\mathcal{K}})_{mni} = \bar{R}_m^l \frac{\partial \bar{R}_n^l}{\partial X^i} = -(\tilde{\mathcal{K}})_{nmi} \quad , \quad (9.235)$$

which reflects the aforementioned skew-symmetry property.

9.8.2.3 Decomposition of deformation into elastic and plastic parts

We assume decomposition (9.172) to apply, and in addition, following Steinmann [149], we put

$$\bar{\mathbf{R}} = \bar{\mathbf{R}}_e \bar{\mathbf{R}}_p \quad . \quad (9.236)$$

We call $\bar{\mathbf{R}}_e$ and $\bar{\mathbf{R}}_p$, respectively the elastic and plastic part of $\bar{\mathbf{R}}$. Like $\bar{\mathbf{R}}$, $\bar{\mathbf{R}}_e$ and $\bar{\mathbf{R}}_p$ are assumed to be rotation tensors. In particular, $\bar{\mathbf{R}}_p$ is postulated to be a two point local deformation field, going from the reference to the plastic intermediate configuration. Consequently, $\bar{\mathbf{R}}_e$ is an incompatible two point tensor field going from the plastic intermediate configuration to the actual one. Similar to the decomposition (9.211), we define decompositions

$$\mathbf{F}_e = \bar{\mathbf{R}}_e \bar{\mathbf{U}}_e = \bar{\mathbf{V}}_e \bar{\mathbf{R}}_e \quad , \quad \mathbf{F}_p = \bar{\mathbf{R}}_p \bar{\mathbf{U}}_p = \bar{\mathbf{V}}_p \bar{\mathbf{R}}_p \quad , \quad (9.237)$$

where $\bar{\mathbf{U}}_e$, $\bar{\mathbf{V}}_p$ are endomorphisms on $T_{\hat{\mathbf{x}}} \hat{R}_t$, $\bar{\mathbf{U}}_p$ is endomorphism on $T_{\mathbf{X}} R_R$ and $\bar{\mathbf{V}}_e$ is endomorphism on $T_{\mathbf{x}} R_t$.

Consider now vectors $\hat{\boldsymbol{\sigma}}'$, $\hat{\boldsymbol{\varphi}}$ at $\hat{\mathbf{x}}$ in the plastic intermediate configuration, given by

$$\hat{\boldsymbol{\sigma}}' = \mathbf{F}_p \boldsymbol{\Sigma}' \quad , \quad \hat{\boldsymbol{\varphi}} = \bar{\mathbf{R}}_p \boldsymbol{\Phi} \quad . \quad (9.238)$$

Then, following additive decompositions apply

$$\Delta_s = (\Delta_s)_e + (\Delta_s)_p \quad , \quad (9.239)$$

$$(\Delta_s)_e := \boldsymbol{\varphi} \cdot \boldsymbol{\sigma}' - \hat{\boldsymbol{\varphi}} \cdot \hat{\boldsymbol{\sigma}}' \quad , \quad (9.240)$$

$$(\Delta_s)_p := \hat{\boldsymbol{\varphi}} \cdot \hat{\boldsymbol{\sigma}}' - \boldsymbol{\Phi} \cdot \boldsymbol{\Sigma}' \quad , \quad (9.241)$$

with $(\Delta_s)_e$, $(\Delta_s)_p$ being expressible form-invariantly. For instance, relative to R_R ,

$$(\Delta_s)_e = \boldsymbol{\Phi} \cdot \tilde{\boldsymbol{\epsilon}}_e \boldsymbol{\Sigma}' \quad , \quad (\Delta_s)_p = \boldsymbol{\Phi} \cdot \tilde{\boldsymbol{\epsilon}}_p \boldsymbol{\Sigma}' \quad , \quad (9.242)$$

$$\tilde{\boldsymbol{\epsilon}}_p = \bar{\mathbf{U}}_p - \mathbf{1} \quad , \quad \tilde{\boldsymbol{\epsilon}} = \tilde{\boldsymbol{\epsilon}}_e + \tilde{\boldsymbol{\epsilon}}_p \quad . \quad (9.243)$$

(Further relations may be found in Grammenoudis and Tsakmakis [67].) $\tilde{\boldsymbol{\epsilon}}_e$ and $\tilde{\boldsymbol{\epsilon}}_p$, or Eulerian counterparts of them, can be used as appropriate strain tensors when formulating micropolar plasticity. To get elastic and plastic parts e.g. of the curvature tensor $\tilde{\boldsymbol{\mathcal{K}}}$, we introduce an additive decomposition of Δ_c , by

$$\Delta_c = (\Delta_c)_e + (\Delta_c)_p \quad , \quad (9.244)$$

$$(\Delta_c)_e := \boldsymbol{\varphi}_1 \cdot (\nabla_{R_t} \boldsymbol{\varphi}_2)[\boldsymbol{\varphi}_3] - \hat{\boldsymbol{\varphi}}_1 \cdot (\nabla_{\hat{R}_t} \hat{\boldsymbol{\varphi}}_2)[\hat{\boldsymbol{\varphi}}_3] \quad , \quad (9.245)$$

$$(\Delta_c)_p := \hat{\boldsymbol{\varphi}}_1 \cdot (\nabla_{\hat{R}_t} \hat{\boldsymbol{\varphi}}_2)[\hat{\boldsymbol{\varphi}}_3] - \boldsymbol{\Phi}_1 \cdot (\nabla_{R_R} \boldsymbol{\Phi}_2)[\boldsymbol{\Phi}_3] \quad , \quad (9.246)$$

where

$$\hat{\boldsymbol{\varphi}}_i := \bar{\mathbf{R}}_p \boldsymbol{\Phi}_i = \bar{\mathbf{R}}_e^T \boldsymbol{\varphi}_i \quad , \quad (9.247)$$

and ∇_{R_t} , ∇_{R_R} are given by (9.222)–(9.224). Operator $\nabla_{\hat{R}_t}$ is a relative covariant derivative defined in analogy to Eq. (9.187)

$$\nabla_{\hat{R}_t} \hat{\boldsymbol{\varphi}}_2 := \left\{ \frac{\partial (\hat{\boldsymbol{\varphi}}_2)^j}{\partial X^i} + \Lambda_{il}^j (\hat{\boldsymbol{\varphi}}_2)^l \right\} \hat{\mathbf{g}}_j \otimes \hat{\mathbf{g}}^i \quad , \quad (9.248)$$

where now

$$\hat{\mathbf{g}}_i \equiv \hat{\mathbf{g}}^i := \bar{\mathbf{R}}_p \mathbf{E}_i \quad , \quad (9.249)$$

and

$$\boldsymbol{\Phi}_2 = (\boldsymbol{\Phi}_2)^i \mathbf{E}_i \quad , \quad \hat{\boldsymbol{\varphi}}_2 = (\hat{\boldsymbol{\varphi}}_2)^i \hat{\mathbf{g}}_i \quad , \quad (\boldsymbol{\Phi}_2)^i = (\hat{\boldsymbol{\varphi}}_2)^i \quad . \quad (9.250)$$

Using similar arguments as in Eqs. (9.187)–(9.194), we get

$$\nabla_{R_R} \boldsymbol{\Phi}_2 = \left\{ \frac{\partial (\boldsymbol{\Phi}_2)^j}{\partial X^i} + \lambda_{il}^j (\boldsymbol{\Phi}_2)^l \right\} \mathbf{E}_j \otimes \mathbf{E}^i \quad , \quad (9.251)$$

$$\hat{\boldsymbol{\varphi}}_1 \cdot (\nabla_{\hat{R}_t} \hat{\boldsymbol{\varphi}}_2)[\hat{\boldsymbol{\varphi}}_3] = \boldsymbol{\Phi}_1 \cdot \left\{ \frac{\partial (\boldsymbol{\Phi}_2)^j}{\partial X^i} + \lambda_{il}^j (\boldsymbol{\Phi}_2)^l \right\} (\mathbf{E}_j \otimes \mathbf{E}^i)[\boldsymbol{\Phi}_3] \quad , \quad (9.252)$$

and thus

$$(\Delta_c)_p = \boldsymbol{\Phi}_1 \cdot \left\{ (\Lambda_{il}^j - \lambda_{il}^j) (\boldsymbol{\Phi}_2 \cdot \mathbf{E}^l) \right\} (\mathbf{E}_j \otimes \mathbf{E}^i)[\boldsymbol{\Phi}_3] = \tilde{\boldsymbol{\mathcal{K}}}_p[\boldsymbol{\Phi}_1, \boldsymbol{\Phi}_2, \boldsymbol{\Phi}_3] \quad (9.253)$$

with

$$\tilde{\mathcal{K}}_p := (\tilde{\mathcal{K}}_p)_{jli} \mathbf{E}^j \otimes \mathbf{E}^l \otimes \mathbf{E}^i \quad , \quad (\tilde{\mathcal{K}}_p)_{jli} = (\Lambda_{jil} - \lambda_{jil}) \quad , \quad (9.254)$$

and $\lambda_{jil} = 0$ (relative to $\{\mathbf{E}_i\}$). It can be seen that

$$(\Delta_c)_e = \tilde{\mathcal{K}}_e[\Phi_1, \Phi_2, \Phi_3] \quad (9.255)$$

with

$$\tilde{\mathcal{K}} = \tilde{\mathcal{K}}_e + \tilde{\mathcal{K}}_p \quad . \quad (9.256)$$

Also, $(\Delta_c)_p$ and $(\Delta_c)_e$ obey form-invariant expressions relative to \hat{R}_t and R_t . For instance, relative to \hat{R}_t ,

$$(\Delta_c)_p = \hat{\mathcal{K}}_p[\hat{\varphi}_1, \hat{\varphi}_2, \hat{\varphi}_3] \quad , \quad (9.257)$$

with

$$\tilde{\mathcal{K}}_p = \mathcal{L}(\bar{\mathbf{R}}_p^T)[\hat{\mathcal{K}}_p] \quad \text{or} \quad \hat{\mathcal{K}}_p = \mathcal{L}(\bar{\mathbf{R}}_p)[\tilde{\mathcal{K}}_p] \quad , \quad (9.258)$$

and so on.

It is worthwhile noting, that $\bar{\mathbf{R}}_p$ induces an Euclidean metric on R_R . In fact, since $\bar{\mathbf{R}}_p$ is orthogonal transformation, the metric tensor $\tilde{\mathbf{G}}$ in Eq. (9.100) reduces to the identity tensor $\mathbf{1}$, with components δ^i_j relative to $\{\mathbf{E}_i\}$. Next assume the connection on R_R , defined by Λ^j_{il} to be metric. Then, with respect to $\{\mathbf{E}_i\}$, only the torsion terms on the righthand side of Eq. (9.290) will be not vanishing,

$$\Lambda^r_{il} = \frac{1}{2}(\mathcal{T}^r_{il} + \mathcal{T}^r_{li} - \mathcal{T}^r_{il}) \quad (9.259)$$

with

$$\mathcal{T}^i_{jk} = (\Lambda^i_{jk} - \Lambda^i_{kj}) \quad \text{or} \quad \mathcal{T}_{ijk} = (\Lambda_{ijk} - \Lambda_{ikj}) \quad . \quad (9.260)$$

It is straightforward to examine from these relations, that Λ_{ril} is skew-symmetric with respect to the indices r, l ,

$$\Lambda_{ril} = -\Lambda_{lir} \quad . \quad (9.261)$$

However, the space R_R structured with (9.260) will generally be not flat and therefore non-Euclidean and non-Riemannian (since $\mathcal{T}^i_{jk} \neq 0$).

Keeping in mind Eq. (9.254) and Eq. (9.261), we conclude that $\tilde{\mathcal{K}}_p$ indicates the same skew-symmetry as $\tilde{\mathcal{K}}$ in Eq. (9.235),

$$(\tilde{\mathcal{K}}_p)_{jli} = -(\tilde{\mathcal{K}}_p)_{lji} \quad . \quad (9.262)$$

By virtue of Eq. (9.256), this skew-symmetry carries over $\tilde{\mathcal{K}}_e$ too.

9.8.2.4 The special case $\Lambda_{il}^j = (\bar{\mathbf{R}}_p^T)^j_n \frac{\partial(\bar{\mathbf{R}}_p)^n_l}{\partial X^i}$

If the special case

$$\Lambda_{il}^j = (\bar{\mathbf{R}}_p^T)^j_n \frac{\partial(\bar{\mathbf{R}}_p)^n_l}{\partial X^i} \quad , \quad \text{respectively} \quad \Lambda_{jil} = (\bar{\mathbf{R}}_p)^n_j \frac{\partial(\bar{\mathbf{R}}_p)^n_l}{\partial X^i} \quad , \quad (9.263)$$

is adopted, which is in agreement with Eq. (9.261), then it can immediately be seen that

$$\tilde{\mathcal{K}}_p = \bar{\mathbf{R}}_p^T \text{GRAD} \bar{\mathbf{R}}_p \quad . \quad (9.264)$$

It has been verified in Eq. (9.98), that the special case (9.263) imposes the condition that the space R_R becomes flat. However, it remains further non-Euclidean and non-Riemannian.

Concluding, we take the opportunity to remark, that a phenomenological micropolar plasticity theory, based on $\tilde{\mathcal{K}}$ in Eq. (9.229), has been proposed in Grammenoudis and Tsakmakis [67]. This theory contains a formal stupid error. If $\tilde{\mathcal{K}}_p$ is defined as in Eq. (9.264), then some compatibility conditions have to be satisfied from $\tilde{\mathcal{K}}_p$. Such compatibility conditions impose constraints on the constitutive theory. Although the kinematical relations have been developed in Grammenoudis and Tsakmakis [67] on the basis of Eq. (9.264), the adopted constitutive theory relies upon a $\tilde{\mathcal{K}}_p$ as in Eq. (9.254), without satisfying some compatibility conditions. However, the entire constitutive theory remains correct, if one thinks of $\tilde{\mathcal{K}}_p$ as being given by Eq. (9.254).

Clearly, various associated time derivatives may be assigned to the strain and curvature tensors by requiring scalars $(\Delta_s)^\cdot$, $(\Delta_s)_e^\cdot$, $(\Delta_s)_p^\cdot$, \dots , $(\Delta_c)^\cdot$, $(\Delta_c)_e^\cdot$, $(\Delta_c)_p^\cdot$, \dots to be form-invariant as well. This has been demonstrated in Grammenoudis and Tsakmakis [67].

Appendix

9.9 Covariant derivative

Most of the relations given in this, and Sect. 9.10, may be consulted in the textbooks e.g. Schouten [141], Schutz [142], Frankel [59], Misner et al. [124], Willmore [168], and Marsden and Hughes [117].

Let \mathbf{v} be a vector field on a three dimensional manifold \mathcal{M} , and \mathbf{u} a vector at (point) $P \in \mathcal{M}$. A (affine) connection on \mathcal{M} is an operator ∇ , which assigns to \mathbf{v} and \mathbf{u} a vector $\nabla_{\mathbf{u}}\mathbf{v}$ at P , called the covariant derivative of \mathbf{v} along \mathbf{u} . For any two real numbers a, b , any vector field \mathbf{w} on \mathcal{M} , any vector \mathbf{z} at P and any scalar field f on \mathcal{M} , the operator is required to satisfy the following properties:

- 1) $\nabla_{\mathbf{u}}\mathbf{v}$ is linear with respect to both \mathbf{u} and \mathbf{v} , i.e.,

$$\nabla_{\mathbf{u}}(a\mathbf{v} + b\mathbf{w}) = a\nabla_{\mathbf{u}}\mathbf{v} + b\nabla_{\mathbf{u}}\mathbf{w} \quad , \quad (9.265)$$

$$\nabla_{(a\mathbf{u}+b\mathbf{z})}\mathbf{v} = a\nabla_{\mathbf{u}}\mathbf{v} + b\nabla_{\mathbf{z}}\mathbf{v} \quad . \quad (9.266)$$

- 2)

$$\nabla_{(f\mathbf{u})}\mathbf{v} = f\nabla_{\mathbf{u}}\mathbf{v} \quad . \quad (9.267)$$

3) Leibniz's rule:

$$\nabla_{\mathbf{u}}(f\mathbf{v}) = (\nabla_{\mathbf{u}}f)\mathbf{v} + f\nabla_{\mathbf{u}}\mathbf{v} \quad . \quad (9.268)$$

In Eq. (9.268), $\nabla_{\mathbf{u}}f$ is defined to be the directional derivative of f in the direction $\mathbf{u} = u^i\mathbf{g}_i$, where $\{\mathbf{g}_i\}$, with Latin indices $i = 1, 2, 3$, is an arbitrary (holonomic or anholonomic) basis on \mathcal{M} ,

$$\nabla_{\mathbf{u}}f := (\text{grad}f) \cdot \mathbf{u} \equiv (\partial_i f)u^i \quad . \quad (9.269)$$

The operator $\partial_i(\cdot)$ denotes the derivative of (\cdot) along the basis vector \mathbf{g}_i . To be more precise, let $\{\theta^\mu\}$, with Greek indices $\mu = 1, 2, 3$, be a coordinate system on \mathcal{M} . (For the purposes of the present paper it suffices to assume, that \mathcal{M} can be covered by a single coordinate system.) Assume that every point $P \in \mathcal{M}$ can be identified by a position vector $\mathbf{x} = \mathbf{x}(\theta^\mu)$ in the space the manifold \mathcal{M} is embedded. At every point on \mathcal{M} , the tangent vectors $\boldsymbol{\xi}_\mu$ on the θ^μ -coordinate lines,

$$\boldsymbol{\xi}_\mu := \frac{\partial \mathbf{x}}{\partial \theta^\mu} \equiv \partial_\mu \mathbf{x} \quad , \quad \text{with} \quad \partial_\mu(\cdot) := \frac{\partial(\cdot)}{\partial \theta^\mu} \quad , \quad (9.270)$$

span a coordinate basis $\{\boldsymbol{\xi}_\mu\}$. The two bases systems $\{\mathbf{g}_i\}$ and $\{\boldsymbol{\xi}_\mu\}$ are related by non-singular transformation matrices \mathbf{A} ,

$$\mathbf{g}_i = A^\mu_i \boldsymbol{\xi}_\mu \quad , \quad \boldsymbol{\xi}_\mu = (\mathbf{A}^{-1})^i_\mu \mathbf{g}_i \quad . \quad (9.271)$$

Then, the operator ∂_i may be expressed in the form

$$\partial_i(\cdot) = A^\mu_i \frac{\partial(\cdot)}{\partial \theta^\mu} \quad . \quad (9.272)$$

Clearly, if $\{\mathbf{g}_i\}$ is holonomic, then A^μ_i is a Jacobi matrix describing a coordinate transformation, and $\partial_i(\cdot)$ reduces to the common partial derivative operator. For instance, we have

$$\mathbf{g}_i = \partial_i \mathbf{x} \quad . \quad (9.273)$$

A connection ∇ on \mathcal{M} is entirely described with respect to the basis $\{\mathbf{g}_i\}$, whenever the vectors $\nabla_{\mathbf{g}_i}\mathbf{g}_j$ are known. Latter can be expressed in terms of the basis $\{\mathbf{g}_i\}$. We put

$$\nabla_{\mathbf{g}_i}\mathbf{g}_j = \Lambda^k_{ij}\mathbf{g}_k \quad . \quad (9.274)$$

Quantities Λ^k_{ij} are called objects or Christoffel symbols of the connection ∇ with respect to the basis $\{\mathbf{g}_i\}$. As $\nabla_{\mathbf{u}}\mathbf{v}$ is linear in \mathbf{u} , there exist a second-order tensor $\nabla\mathbf{v}$, referred to as covariant derivative of \mathbf{v} , so that

$$\nabla_{\mathbf{u}}\mathbf{v} = \nabla\mathbf{v}[\mathbf{u}] \quad . \quad (9.275)$$

For $\mathbf{v} = v^i\mathbf{g}_i$, axioms 1)–3) imply

$$\nabla\mathbf{v} = (\partial_j v^i + \Lambda^i_{jr}v^r)\mathbf{g}_i \otimes \mathbf{g}^j \quad . \quad (9.276)$$

Let Λ^s_{kr} and Λ'^n_{im} be objects of the same connection relative to the arbitrary (holonomic or anholonomic) bases $\{\mathbf{g}_i\}$ and $\{\mathbf{g}'_i\}$, respectively. Also assume the bases to be related through

$$\mathbf{g}'_i = A^l_i \mathbf{g}_l \quad . \quad (9.277)$$

Then, the transformation rule

$$\Lambda'^n_{im} = (\mathbf{A}^{-1})^n_s A^k_i A^r_m \Lambda^s_{kr} + (\mathbf{A}^{-1})^n_r \partial'_i A^r_m \quad (9.278)$$

applies, where $\partial'_i(\cdot)$ denotes the derivative of (\cdot) along \mathbf{g}'_i .

A curve on \mathcal{M} , parameterized by λ , is a function of the form $\sigma = \sigma(\theta^\mu(\lambda))$. The graph of this function is a line σ_λ on \mathcal{M} . By using the abbreviation $(\cdot)' := \frac{d(\cdot)}{d\lambda}$, the tangent vector

$$\mathbf{u}(\lambda) := \dot{\sigma}(\lambda) = u^i(\lambda) \mathbf{g}_i(\lambda) = \bar{u}^\mu(\lambda) \boldsymbol{\xi}_\mu(\lambda) \quad (9.279)$$

on σ_λ becomes

$$\mathbf{u}(\lambda) = \frac{\partial \sigma}{\partial \theta^\mu} \dot{\theta}^\mu = \dot{\theta}^\mu \boldsymbol{\xi}_\mu \quad (9.280)$$

Keeping in mind Eq. (9.271), and taking into account that $\bar{u}^\mu \equiv \dot{\theta}^\mu$, we get

$$u^i = (\mathbf{A}^{-1})^i_\mu \dot{\theta}^\mu \quad (9.281)$$

The covariant derivative of a vector field $\mathbf{v} = v^i \mathbf{g}_i$ along σ_λ , denoted by $\frac{D\mathbf{v}}{D\lambda}$, is defined by

$$\frac{D\mathbf{v}}{D\lambda} := \nabla_{\mathbf{u}(\lambda)} \mathbf{v} = (u^j \partial_j v^i + \Lambda^i_{jr} u^j v^r) \mathbf{g}_i \quad (9.282)$$

Let φ be a scalar field on \mathcal{M} . The derivative of φ along σ_λ is given by

$$\dot{\varphi}(\lambda) = \frac{d\varphi(\theta^\mu(\lambda))}{d\lambda} = \frac{\partial \varphi}{\partial \theta^\mu} \dot{\theta}^\mu = \frac{\partial \varphi}{\partial \theta^\mu} A^\mu_j u^j = u^j \partial_j \varphi \quad (9.283)$$

With the help of this result, Eq. (9.282) yields

$$\frac{D\mathbf{v}}{D\lambda} = \left(\frac{dv^i}{d\lambda} + \Lambda^i_{jr} u^j v^r \right) \mathbf{g}_i \quad (9.284)$$

According to the righthand side of this equation, the vector \mathbf{v} needs to be defined only along σ_λ .

Let \mathbf{v} , \mathbf{w} be vector fields on \mathcal{M} and $f(\lambda)$ scalar field along σ_λ . Then, it is readily shown that the covariant derivative along σ_λ , given by (9.284), satisfies the following properties:

1)

$$\frac{D}{D\lambda}(\mathbf{v} + \mathbf{w}) = \frac{D\mathbf{v}}{D\lambda} + \frac{D\mathbf{w}}{D\lambda} \quad (9.285)$$

2)

$$\frac{D}{D\lambda}(f\mathbf{v}) = \frac{df}{d\lambda} \mathbf{v} + f \frac{D\mathbf{v}}{D\lambda} \quad (9.286)$$

3) If $\boldsymbol{\omega}$ is vector field on \mathcal{M} and $\mathbf{v}(\lambda)$ is the restriction of $\boldsymbol{\omega}$ on σ_λ , $\mathbf{v}(\lambda) = \boldsymbol{\omega}(\sigma(\lambda))$, then

$$\frac{D\mathbf{v}}{D\lambda} = \nabla_{\sigma(\lambda)} \boldsymbol{\omega} \quad (9.287)$$

On the other hand, properties 1)–3) may be imposed as axioms for defining a covariant derivative along σ_λ . In doing this, the vector field to be differentiated is required to be defined only along σ_λ (cf. Willmore [168], p. 45)

9.10 Torsion, Riemann curvature tensor

Consider two vector fields \mathbf{u}, \mathbf{v} on \mathcal{M} and let Λ^i_{jk} , as above, be the Christoffel symbols of the connection with respect to the arbitrary basis $\{\mathbf{g}_i\}$. The torsion of the connection is a third-order tensor \mathcal{T} , defined by

$$\mathcal{T}[\cdot, \mathbf{u}, \mathbf{v}] := \nabla_{\mathbf{u}}\mathbf{v} - \nabla_{\mathbf{v}}\mathbf{u} - [\mathbf{u}, \mathbf{v}] \quad , \quad (9.288)$$

where $[\mathbf{u}, \mathbf{v}]$ is the Lie bracket of \mathbf{u}, \mathbf{v} . With respect to $\{\mathbf{g}_i\}$, the components of \mathcal{T} are

$$\mathcal{T}^i_{jk} = (\Lambda^i_{jk} - \Lambda^i_{kj}) - \mathcal{C}^i_{jk} \quad , \quad (9.289)$$

with \mathcal{C}^i_{jk} being the objects of anholonomy for the chosen basis $\{\mathbf{g}_i\}$ (see Schouten [141]). The connection is called torsion-free or symmetric, if \mathcal{T} is vanishing, while the objects of connection Λ^i_{jk} are called symmetric if $\Lambda^i_{jk} = \Lambda^i_{kj}$.

Two cases are of particular interest:

- a) The chosen basis is holonomic, so that $\mathcal{C}^i_{jk} = 0$ and $\mathcal{T}^i_{jk} = \Lambda^i_{jk} - \Lambda^i_{kj}$. In this case the connection is symmetric if and only if its objects Λ^i_{jk} are symmetric.
- b) The chosen basis is anholonomic, so that $\mathcal{C}^i_{jk} \neq 0$. Then, the connection is symmetric if and only if $\mathcal{T}^i_{jk} = 0$, or $\Lambda^i_{jk} - \Lambda^i_{kj} = \mathcal{C}^i_{jk}$. That means, the objects Λ^i_{jk} are not symmetric. If $\mathcal{T}^i_{jk} \neq 0$, then Λ^i_{jk} may be or may not be symmetric.

More generally, the connection may be characterized by the formula

$$\Lambda^r_{jl} = \frac{1}{2}g^{rk}(\partial_l g_{ik} + \partial_i g_{kl} - \partial_k g_{li}) + \frac{1}{2}(\mathcal{T}^r_{il} + \mathcal{T}^r_{li} - \mathcal{T}^r_{il}) + \frac{1}{2}(\mathcal{C}^r_{il} + \mathcal{C}^r_{li} - \mathcal{C}^r_{il}) + \frac{1}{2}(\mathcal{Q}_{li}^r + \mathcal{Q}_{il}^r - \mathcal{Q}_{li}^r) \quad , \quad (9.290)$$

where quantities g_{ij} and g^{ij} are used to raise and lower indices, and

$$-\mathcal{Q}_{lik} \equiv -\mathcal{Q}_{lki} := \partial_l g_{ik} - \Lambda^m_{li} g_{mk} - \Lambda^m_{lk} g_{im} \quad . \quad (9.291)$$

Objects \mathcal{Q}_{lik} describe the compatibility of the connection with the metric, i.e., \mathcal{Q}_{lik} measures the lack of vanishing of the covariant derivative of the metric.

Formula (9.290) suggests to distinguish between three cases:

- a) The connection is symmetric (torsion-free). Then the expression in brackets enclosing the torsion terms is vanishing.
- b) The chosen basis is holonomic. Then the expression in brackets enclosing objects of anholonomy is vanishing.
- c) The connection is metric with respect to g_{ik} . Then the expression in the last brackets on the righthand side of (9.290) is vanishing.

On manifolds endowed with a metric, the following "fundamental theorem of Riemannian geometry" holds: There exists a unique, so-called Levi Civita connection, which is symmetric (torsion-free) and metric, i.e. parallel translation preserves inner products. The proof of this can be found in textbooks

on differential geometry. We shall use the letter Λ to denote the Levi Civita connection. For instance, in the present context Λ^i_{jl} are the symbols of the Levi Civita connection relative to $\{\mathbf{g}_i\}$.

Aside from the metric and the connection, the manifold may be characterized by the Riemann (or Riemann-Christoffel) curvature tensor \mathcal{R} of the connection, which is a fourth-order tensor. With respect to the arbitrary basis $\{\mathbf{g}_i\}$, the components of \mathcal{R} are given by

$$\mathcal{R}^r_{ijm} = \partial_j \Lambda^r_{mi} - \partial_m \Lambda^r_{ji} + \Lambda^r_{jn} \Lambda^n_{mi} - \Lambda^r_{mn} \Lambda^n_{ji} + C^n_{mj} \Lambda^r_{ni} \quad . \quad (9.292)$$

An Euclidean manifold is endowed with both an Euclidean metric and a Levi-Civita connection, the objects of which vanish with respect to Cartesian coordinate systems. Hence, the Riemann curvature tensor vanishes too. The reversed statement (see Schouten [141], p. 142) asserts that every manifold endowed with a symmetric, metric connection, and vanishing Riemann curvature tensor, is an Euclidean one.

In manifolds with vanishing Riemann curvature tensor, parallel translation of vectors of a point P to a point Q is path independent. Such manifolds are said to be flat, or to possess teleparallelism. The manifold is said to be Riemannian, if it is endowed with a Riemannian metric, a symmetric, metric connection, and a non-vanishing Riemann curvature tensor. One says also that the manifold is curved. In plasticity theories it can happen, that the manifold is structured with non-Euclidean metric, and a non-metric and non-symmetric connection. The Riemann curvature tensor may vanish or not. Such manifolds are generally called as non-Riemannian and non-Euclidean.

9.11 Transformation of relative gradients under change of basis

In order to prove results (9.90), (9.91), we rewrite Eq. (9.89) by using Eq. (9.70),

$$(\mathbf{g}_\Psi^*)_i = A^l_i \Psi \mathbf{E}_l = \Psi \mathbf{E}_i^* \quad , \quad (9.293)$$

$$\mathbf{E}_i^* := A^l_i \mathbf{E}_l \quad \text{or} \quad \mathbf{E}_i = (\mathbf{A}^{-1})^j_i \mathbf{E}_j^* \quad , \quad (9.294)$$

and furthermore

$$(\mathbf{g}_\Psi^*)^i = (\mathbf{A}^{-1})^i_l \Psi^{T-1} \mathbf{E}^l = \Psi^{T-1} \mathbf{E}^{*i} \quad , \quad (9.295)$$

$$\mathbf{E}^{*i} = (\mathbf{A}^{-1})^i_j \mathbf{E}^j \quad \text{or} \quad \mathbf{E}^i = A^i_j \mathbf{E}^{*j} \quad . \quad (9.296)$$

In opposite to $\{\mathbf{E}_i\}$, the basis $\{\mathbf{E}_i^*\}$ needs not to be orthonormal and it may be anholonomic. From Eq. (9.71), it follows that

$$\bar{\nabla}_\Psi \mathbf{b} = \left(\frac{\partial \mathbf{b}}{\partial X^i} \otimes A^i_j \mathbf{E}^{*j} \right) \Psi^{-1} \quad . \quad (9.297)$$

On defining the derivatives along \mathbf{g}_i^* and along $(\partial_\Psi^*)_i$, respectively by

$$\partial_i^*(\cdot) := A^j_i \frac{\partial(\cdot)}{\partial X^j} \quad , \quad (\partial_\Psi^*)_i(\cdot) := A^j_i (\partial_\Psi)_j(\cdot) \quad , \quad (9.298)$$

we obtain from Eq. (9.297)

$$\bar{\nabla}_\Psi \mathbf{b} = (\partial_i^* \mathbf{b} \otimes \mathbf{E}^{*i}) \Psi^{-1} = \partial_i^* \mathbf{b} \otimes (\mathbf{g}_\Psi^*)^i \quad , \quad (9.299)$$

or, in view of Eq. (9.92),

$$\bar{\nabla}_{\Psi} \mathbf{b} = \{(\partial_i^* b^{*m})(\mathbf{g}_{\Psi}^*)_m + b^{*m} \partial_i^*(\mathbf{g}_{\Psi}^*)_m\} \otimes (\mathbf{g}_{\Psi}^*)^i \quad . \quad (9.300)$$

To recast the term $\partial_i^*(\mathbf{g}_{\Psi}^*)_m$, we substitute Eq. (9.73) into Eq. (9.293),

$$(\mathbf{g}_{\Psi}^*)_m = A^l_m \Psi^j_l \mathbf{e}_j \quad \text{or} \quad \mathbf{e}_j = (\mathbf{A}^{-1})^n_k (\Psi^{-1})^k_j (\mathbf{g}_{\Psi}^*)_n \quad . \quad (9.301)$$

This leads to

$$\begin{aligned} \partial_i^*(\mathbf{g}_{\Psi}^*)_m &= A^l_m (\partial_i^* \Psi^j_l) \mathbf{e}_j + (\partial_i^* A^l_m) \Psi^j_l \mathbf{e}_j \\ &= A^l_m (\partial_i^* \Psi^j_l) (\mathbf{A}^{-1})^n_r (\Psi^{-1})^r_j (\mathbf{g}_{\Psi}^*)_n + (\partial_i^* A^l_m) \Psi^j_l (\mathbf{A}^{-1})^n_r (\Psi^{-1})^r_j (\mathbf{g}_{\Psi}^*)_n \\ &= \left\{ A^k_m (\mathbf{A}^{-1})^n_l A^p_i (\Psi^{-1})^l_j \frac{\partial \Psi^j_k}{\partial X^p} + (\mathbf{A}^{-1})^n_r \partial_i^* A^r_m \right\} (\mathbf{g}_{\Psi}^*)_n \\ &= \{(\mathbf{A}^{-1})^n_s A^k_i A^r_m (\Lambda_{\Psi})^s_{kr} + (\mathbf{A}^{-1})^n_r \partial_i^* A^r_m\} (\mathbf{g}_{\Psi}^*)_n \quad , \end{aligned} \quad (9.302)$$

and after inserting into Eq. (9.300),

$$\bar{\nabla}_{\Psi} \mathbf{b} = \{\partial_i^* b^{*n} + [(\mathbf{A}^{-1})^n_s A^k_i A^r_m (\Lambda_{\Psi})^s_{kr} + (\mathbf{A}^{-1})^n_r \partial_i^* A^r_m] b^{*m}\} (\mathbf{g}_{\Psi}^*)_n \otimes (\mathbf{g}_{\Psi}^*)^i \quad . \quad (9.303)$$

Finally,

$$\bar{\nabla}_{\Psi} \mathbf{b} = \{\partial_i^* b^{*n} + (\Lambda_{\Psi}^*)^n_{im} b^{*m}\} (\mathbf{g}_{\Psi}^*)_n \otimes (\mathbf{g}_{\Psi}^*)^i \quad , \quad (9.304)$$

with

$$(\Lambda_{\Psi}^*)^n_{im} = (\mathbf{A}^{-1})^n_s A^k_i A^r_m (\Lambda_{\Psi})^s_{kr} + (\mathbf{A}^{-1})^n_r A^j_i \frac{\partial A^r_m}{\partial X^j} \quad . \quad (9.305)$$

10 Plastic intermediate configuration and related spatial differential operators in micromorphic plasticity

P. Grammenoudis, Ch. Tsakmakis

**Mathematics and Mechanics of Solids, in press
Online First DOI 10.1177/1081286509104829**

Plastic intermediate configuration and related spatial differential operators in micromorphic plasticity

P. Grammenoudis, Ch. Tsakmakis

**Darmstadt University of Technology, Institute of Continuum Mechanics,
Hochschulstraße 1, 64289 Darmstadt, Germany**

Abstract

Finite deformation kinematics of micromorphic plasticity is discussed in the framework of multiplicative decomposition of the macro- and microdeformation gradient tensor, suggesting to introduce a so-called plastic intermediate configuration for the micromorphic continuum. The geometrical structure of the plastic intermediate configuration is elucidated with reference to so-called relative covariant derivatives, appropriately defined in the article. Attention is focused on micromorphic curvature tensors, introduced by invoking the differential operator of relative covariant derivative with respect to the plastic intermediate configuration. Curvature tensors arise in a natural way by considering scalar valued differences. Latter measure the deformation process and are required to be form-invariant with respect to the chosen configuration.

10.1 Introduction

A study of bodies with inhomogeneities from the point of view of local deformations has been given by Noll [129] (see also [155], Sects. 22, 34), who introduced also the term relative gradient, for some spatial differential operators related to local deformations. Le and Stumpf (see [98, 99]) applied the mathematical and physical framework of Noll's approach to incorporate the multiplicative decomposition of the deformation gradient tensor into elastic and plastic parts in continuum theories of dislocations. Local, incompatible deformations related to inelasticity have been broadly elaborated in nonlocal crystal plasticity theories. Such theories, the investigation of which has been initiated by Kondo (see, e.g., [94]), Bilby et al. (see, e.g., [9]) and Kröner (see, e.g., [95]) deal with the torsion of the space as variable (see among others Le and Stumpf [98, 99], Gurtin [79, 80], Epstein and Maugin [44], Dluzewski [40]). The references cited above are concerned with continuum theories of defects fitted in the framework of non-polar materials. However, there are continuum theories of defects which belong, e.g., to the class of micropolar materials. Fundamental concepts concerning continuum defects theories and micropolar degrees of freedom are addressed, e.g., in the works of Minagawa [119, 120], Antony [6], Hehl and Kröner [84], Günther [65], Eringen and Claus [47] and Clayton et al. [26]. Generally, whenever use is made from relative gradients, the space will be flat and non-torsion free. Such non-Euclidean and non-Riemannian spaces are known to possess teleparallelism.

Noll's approach of relative gradient is extended in Grammenoudis and Tsakmakis [72] by defining the notion of relative covariant derivative. This has been elaborated in the multiplicative decomposition

of deformation of classical and micropolar plasticity to obtain additive decompositions of micropolar curvature tensors. Generally, relative covariant derivatives endow the space with a non-torsion free connection and a non-vanishing Riemannian curvature tensor. Such spaces have been addressed by Kondo [94] in the context of general continuum theories of defects.

In the present article, a so-called plastic intermediate configuration is introduced in micromorphic plasticity by postulating the multiplicative decomposition into elastic and plastic parts of the deformation gradient tensor for both, the macroscopic and the microscopic continuum. Latter is attached at every point of the macroscopic body and undergoes homogeneous deformations only. The geometrical structure of the plastic intermediate configuration is investigated by using differential operations in form of relative covariant derivative with respect to this configuration. Transformation of the relative covariant derivative to the reference configuration furnishes a connection for the reference configuration, which geometrically is non-torsion free and its Riemannian curvature tensor is non-vanishing. Micromorphic continuum theories include, as kinematical variables, micromorphic curvature tensors which are related, in some way, with the gradient of the microdeformation gradient tensor. Geometrically, micromorphic curvature tensors are introduced in the article by considering scalar differences measuring the deformation of the micro- and the macroscopic continuum, and by requiring from these scalar differences to be form-invariant with respect to the chosen configuration. This applies also for decomposition of deformations, which are incorporated suitably by invoking the operator of relative covariant derivative.

10.2 Notation

Tensor operations in the article are referred to Euclidean vector spaces. Let \mathbb{E} be a three-dimensional Euclidean vector space, and $\{\mathbf{e}_i\}$ an orthonormal basis in \mathbb{E} . If nothing others is stated, then all indices have the range of the integers $(1, 2, 3)$, while summation over repeated indices is implied. For the purposes of the article, it suffices to make use of the notation of classical continuum mechanics, i.e., we shall not distinguish between \mathbb{E} and its dual space. Thus, tensors of arbitrary order on \mathbb{E} will be regarded as multilinear functions on \mathbb{E} . The following relationships are referred to tensors on \mathbb{E} , but otherwise can analogously be extended to so-called two point tensors.

Letters set in boldface designate vectors or second-order tensors, while third-order tensors are denoted by calligraphic boldface letters. In particular, $\mathbf{a} \cdot \mathbf{b}$, and $\mathbf{a} \otimes \mathbf{b}$ denote the inner, and the tensor product of the vectors \mathbf{a} and \mathbf{b} , respectively. For second-order tensors \mathbf{A} and \mathbf{B} , we write $\text{tr}\mathbf{A}$ for the trace, $\det \mathbf{A}$ for the determinant and \mathbf{A}^T for the transpose of \mathbf{A} , while $\mathbf{A} \cdot \mathbf{B} = \text{tr}(\mathbf{A}\mathbf{B}^T)$ is the inner product between \mathbf{A} and \mathbf{B} . Furthermore,

$$\mathbf{1} = \delta_{ij} \mathbf{e}_i \otimes \mathbf{e}_j \quad (10.1)$$

represents the identity tensor of second-order, where $\delta_{ij} = \delta_j^i$ is the Kronecker delta. Often use is made of notations of the form $a_i = (\mathbf{a})_i$, $A_{ij} = (\mathbf{A})_{ij}$, \dots , for the components of vectors \mathbf{a} , second-order tensors \mathbf{A} , and so on. Also, we use the notation $\mathbf{A}^{T-1} = (\mathbf{A}^{-1})^T$, provided $\det \mathbf{A} \neq 0$.

Let $\mathbf{v} = v_i \mathbf{e}_i$, $\mathbf{w} = w_i \mathbf{e}_i$, $\mathbf{u} = u_i \mathbf{e}_i$, $\mathbf{z} = z_i \mathbf{e}_i$ be vectors, $\mathbf{A} = A_{ij} \mathbf{e}_i \otimes \mathbf{e}_j$, $\mathbf{B} = B_{ij} \mathbf{e}_i \otimes \mathbf{e}_j$, $\mathbf{C} = C_{ij} \mathbf{e}_i \otimes \mathbf{e}_j$ be second-order tensors, and $\mathcal{M} = \mathcal{M}_{ijkl} \mathbf{e}_i \otimes \mathbf{e}_j \otimes \mathbf{e}_k \otimes \mathbf{e}_l$ be third-order tensor. Then,

$$\mathbf{A}\mathbf{v} \equiv \mathbf{A}[\mathbf{v}] = A_{ij} v_j \mathbf{e}_i \quad , \quad (10.2)$$

$$\mathbf{A}[\mathbf{v}, \mathbf{w}] = \mathbf{v} \cdot \mathbf{A}\mathbf{w} = v_i A_{ij} w_j \quad , \quad (10.3)$$

$$\mathbf{AB} = (A_{ij}\mathbf{e}_i \otimes \mathbf{e}_j)\mathbf{B} = A_{ij}\mathbf{e}_i \otimes \mathbf{B}^T\mathbf{e}_j = A_{ij}B_{jm}\mathbf{e}_i \otimes \mathbf{e}_m \quad , \quad (10.4)$$

$$\mathbf{A}^2 = \mathbf{AA} = A_{ij}A_{jk}\mathbf{e}_i \otimes \mathbf{e}_k \quad , \quad (10.5)$$

$$\mathcal{M}[\mathbf{v}, \mathbf{w}, \mathbf{u}] = \mathcal{M}_{ijk}(\mathbf{e}_i \cdot \mathbf{v})(\mathbf{e}_j \cdot \mathbf{w})(\mathbf{e}_k \cdot \mathbf{u}) \quad . \quad (10.6)$$

\mathbf{AM} , \mathcal{MA}^T and $\mathbf{A} \diamond \mathcal{M} \equiv \mathcal{M} \diamond \mathbf{A}^T$ are defined to represent third-order tensors given by

$$\mathbf{AM} := \mathcal{M}_{ijk}(\mathbf{A}\mathbf{e}_i) \otimes \mathbf{e}_j \otimes \mathbf{e}_k = A_{mi}\mathcal{M}_{ijk}\mathbf{e}_m \otimes \mathbf{e}_j \otimes \mathbf{e}_k \quad , \quad (10.7)$$

$$\mathcal{MA}^T := \mathcal{M}_{ijk}\mathbf{e}_i \otimes \mathbf{e}_j \otimes (\mathbf{A}\mathbf{e}_k) = \mathcal{M}_{ijk}A_{mk}\mathbf{e}_i \otimes \mathbf{e}_j \otimes \mathbf{e}_m \quad , \quad (10.8)$$

$$\mathbf{A} \diamond \mathcal{M} \equiv \mathcal{M} \diamond \mathbf{A}^T := \mathcal{M}_{ijk}\mathbf{e}_i \otimes (\mathbf{A}\mathbf{e}_j) \otimes \mathbf{e}_k = \mathcal{M}_{ijk}A_{mj}\mathbf{e}_i \otimes \mathbf{e}_m \otimes \mathbf{e}_k \quad . \quad (10.9)$$

If $\mathcal{M} = \mathbf{B} \otimes \mathbf{z}$, then

$$\mathbf{AM} = \mathbf{A}(\mathbf{B} \otimes \mathbf{z}) = (\mathbf{AB}) \otimes \mathbf{z} \quad , \quad (10.10)$$

$$\mathcal{MA}^T = (\mathbf{B} \otimes \mathbf{z})\mathbf{A}^T = \mathbf{B} \otimes (\mathbf{Az}) \quad , \quad (10.11)$$

$$\mathbf{A} \diamond \mathcal{M} \equiv \mathcal{M} \diamond \mathbf{A}^T = (\mathbf{BA}^T) \otimes \mathbf{z} \quad , \quad (10.12)$$

and

$$\mathcal{M}[\mathbf{v}, \mathbf{w}, \mathbf{u}] = (\mathbf{B} \otimes \mathbf{z})[\mathbf{v}, \mathbf{w}, \mathbf{u}] = (\mathbf{v} \cdot \mathbf{B}\mathbf{w})(\mathbf{z} \cdot \mathbf{u}) \quad . \quad (10.13)$$

To the second-order tensors \mathbf{A} , \mathbf{B} , \mathbf{C} , a linear operator $\mathcal{L}(\mathbf{A}, \mathbf{B}, \mathbf{C})$ can be assigned, which acts on third-order tensors \mathcal{M} and generates third-order tensors

$$\mathcal{L}(\mathbf{A}, \mathbf{B}, \mathbf{C})[\mathcal{M}] := \mathcal{M}_{ijk}(\mathbf{A}\mathbf{e}_i) \otimes (\mathbf{B}\mathbf{e}_j) \otimes (\mathbf{C}\mathbf{e}_k) \quad . \quad (10.14)$$

If \mathcal{M} is a manifold, then $T\mathcal{M}$ is the tangent bundle of \mathcal{M} ,

$$T\mathcal{M} := \bigcup_{p \in \mathcal{M}} T_p\mathcal{M} \quad , \quad (10.15)$$

where $T_p\mathcal{M}$ is the tangent space to \mathcal{M} at p .

10.3 Kinematic of micromorphic continuum

10.3.1 Reference and actual configuration

Let \mathcal{B} be a material body (macroscopic continuum, or macrocontinuum, or macroscopic material, or overall material body), with elements \mathcal{X} , \mathcal{Y} , \dots , which may be mapped into a region of the three dimensional Euclidean space \mathcal{E} . With origin O fixed in \mathcal{E} , every point $P \in \mathcal{E}$ may be identified by a position vector \mathbf{p} , which belongs to the tangent space to \mathcal{E} at O . As usually in classical continuum mechanics, we shall often set \mathbf{p} equal to point P , and we shall speak of the point $\mathbf{p} \in \mathcal{E}$.

Assume a material body $\mathcal{B}'(\mathcal{X})$ (microcontinuum, or microstructure), with elements \mathcal{X}' , \mathcal{Y}' , \dots , to be attached at each material point $\mathcal{X} \in \mathcal{B}$, and suppose that the same body \mathcal{B}' is attached at every \mathcal{X} . A configuration of the body \mathcal{B} and its microstructure \mathcal{B}' is a map

$$(k, k') : (\mathcal{B}, \mathcal{B}') \rightarrow \mathcal{E} \times \mathcal{E} \quad , \quad (10.16)$$

$$(\chi, \chi') \mapsto \begin{pmatrix} k = k(\mathcal{X}) \\ k' = k'(\mathcal{X}, \mathcal{X}') \end{pmatrix}, \quad (10.17)$$

with $k(\mathcal{B})$, $k'(\mathcal{X}, \mathcal{B}')$ open and simply connected subsets of \mathcal{E} . $k(\mathcal{B})$ and $k'(\mathcal{X}, \mathcal{B}')$ are denoted as the ranges in \mathcal{E} occupied under the configuration (k, k') . We shall also write $(k, k') \equiv (\mathbf{k}, \mathbf{k}')$, and we shall set $k(\mathcal{B}) \equiv \mathbf{k}(\mathcal{B})$, $k'(\mathcal{X}, \mathcal{B}') \equiv \mathbf{k}'(\mathcal{X}, \mathcal{B}')$, where $\mathbf{k}(\mathcal{X})$ is a position vector with respect to origin O , and $\mathbf{k}'(\mathcal{X}, \mathcal{X}')$ is a position vector emanated from point $\mathbf{k}(\mathcal{X}) \in \mathcal{E}$ and leading to point in space occupied by \mathcal{X}' .

A fixed chosen configuration (χ_R, χ'_R) is called reference configuration of $(\mathcal{B}, \mathcal{B}')$,

$$(\mathcal{X}, \mathcal{X}') \mapsto \begin{pmatrix} \mathbf{X} = \chi_R(\mathcal{X}) \\ \mathbf{X}' = \chi'_R(\mathcal{X}, \mathcal{X}') \end{pmatrix}, \quad (10.18)$$

while a motion of $(\mathcal{B}, \mathcal{B}')$ in $\mathcal{E} \times \mathcal{E}$ is an one parameter family of configurations (χ, χ') , parameterized with time $t \in I$ ($I \subset \mathbb{R}$, I : interval),

$$(\chi, \chi') : \mathcal{B} \times \mathcal{B}' \times I \rightarrow \mathcal{E} \times \mathcal{E}, \quad (10.19)$$

$$(\mathcal{X}, \mathcal{X}', t) \mapsto \begin{pmatrix} \mathbf{x} = \chi(\mathcal{X}, t) \\ \mathbf{x}' = \chi'(\mathcal{X}, \mathcal{X}', t) \end{pmatrix}. \quad (10.20)$$

We suppose, that for fixed time t , the map (χ, χ') posses an inverse, so that \mathcal{X} , \mathcal{X}' may be expressed in terms of \mathbf{x} , \mathbf{x}' . If the motion of $(\mathcal{B}, \mathcal{B}')$ starts at time t_0 , then the configuration $(\chi(\cdot, t_0), \chi'(\cdot, \cdot, t_0))$ is called the initial configuration. Accordingly, the configuration $(\chi(\cdot, t), \chi'(\cdot, \cdot, t))$ is denoted as actual or current or Eulerian configuration. In this article, we assume the initial configuration at time t_0 to coincide with the reference configuration,

$$\mathbf{x} = \chi(\mathcal{X}, t_0) \equiv \chi_R(\mathcal{X}), \quad (10.21)$$

$$\mathbf{x}' = \chi'(\mathcal{X}, \mathcal{X}', t_0) \equiv \chi'_R(\mathcal{X}, \mathcal{X}'). \quad (10.22)$$

It is common to call configurations different than the reference configuration as spatial ones. Also, it is assumed that, for fixed t , all inverse functions exist, so that the motion can be expressed in terms of \mathbf{X} , \mathbf{X}' . If no confusion may arise, following common praxis, we shall use the same symbols for these functions as in Equation (10.20),

$$(\mathbf{X}, \mathbf{X}', t) \mapsto \begin{pmatrix} \mathbf{x} = \chi(\mathbf{X}, t) \\ \mathbf{x}' = \chi'(\mathbf{X}, \mathbf{X}', t) \end{pmatrix}. \quad (10.23)$$

Functions (χ, χ') in this equation, for fixed time t , are referred to as deformation from the reference to the actual configuration. We shall refer to the ranges in space $R_R := \chi_R(\mathcal{B})$, $R_t := \chi(\mathcal{B}, t)$, $R'_R(\mathbf{X}) := \chi'_R(\mathcal{X}, \mathcal{B}')$, $R'_t(\mathbf{x}) := \chi'(\mathcal{X}, \mathcal{B}', t)$.

The introduction of microstructures into the theory goes back to Mindlin [122] and Eringen (see, e.g., [49, 46]). Here, the mass of the microcontinuum is assumed to be continuously distributed. Generally, the microcontinuum as adopted in the present article, is a fictitious (conceptual) one, which may have arbitrary finite dimensions (see Fig. 10.1), i.e., the region in \mathcal{E} occupied by the microcontinuum at a material point of the macroscopic material, must not necessarily be subset of the region occupied by the macroscopic material itself (see also Grammenoudis and Tsakmakis [71], where this kind of microcontinuum has been invoked in a micropolar plasticity theory). Following Eringen (see, e.g., [46]), we denote the material body, with a microstructure at each material point, as a micromorphic continuum, if the microstructure undergoes homogeneous deformations only.

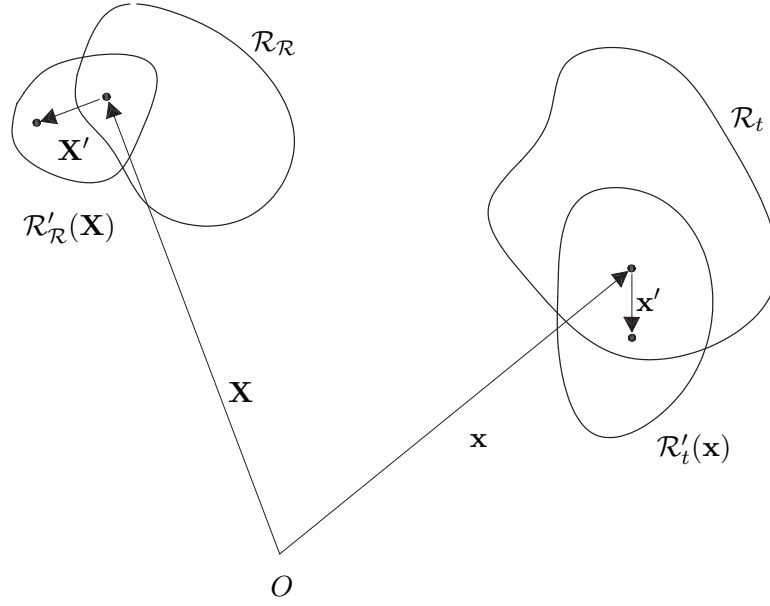

Figure 10.1: The region $\mathcal{R}'_{\mathcal{R}}(\mathbf{X})$ (respectively $\mathcal{R}'_t(\mathbf{x})$) must not necessarily be subset of the region $\mathcal{R}_{\mathcal{R}}$ (respectively \mathcal{R}_t).

10.3.2 Micro- and macrodeformation gradient

As is standard, we refer to

$$\mathbf{F} = \mathbf{F}(\mathbf{X}, t) = \frac{\partial \chi(\mathbf{X}, t)}{\partial \mathbf{X}} = \text{GRAD} \chi(\mathbf{X}, t) \quad (10.24)$$

as the macrodeformation gradient or macroscopic deformation gradient tensor, where $\det \mathbf{F} > 0$ is assumed. We distinguish between the operators GRAD and grad, representing the gradient with respect to \mathbf{X} and \mathbf{x} , respectively. Note that \mathbf{F} is a two-point tensor field, i.e., $\mathbf{F}(\mathbf{X}, t) : T_{\mathbf{X}}\mathcal{R}_{\mathcal{R}} \rightarrow T_{\mathbf{x}}\mathcal{R}_t$.

The deformation of the microscopic continuum is described by the microdeformation gradient tensor

$$\mathbf{f} = \mathbf{f}(\mathbf{X}, \mathbf{X}', t) := \frac{\partial \chi'(\mathbf{X}, \mathbf{X}', t)}{\partial \mathbf{X}'} \quad , \quad (10.25)$$

with $\det \mathbf{f} > 0$ being assumed. As the microscopic continuum suffers homogeneous deformations only, we have $\mathbf{f}(\mathbf{X}, \mathbf{X}', t) \equiv \mathbf{f}(\mathbf{X}, t)$.

With regard to the motion of the macroscopic material, $\mathbf{f}(\mathbf{X}, t)$ may be imagined to be, like $\mathbf{F}(\mathbf{X}, t)$, a two point tensor field, $\mathbf{f}(\mathbf{X}, t) : T_{\mathbf{X}}\mathcal{R}_{\mathcal{R}} \rightarrow T_{\mathbf{x}}\mathcal{R}_t$. Moreover, from Eq. (10.23), the motion of the micromorphic continuum may be written in the form

$$(\mathbf{X}, \mathbf{X}', t) \mapsto \begin{pmatrix} \mathbf{x} = \chi(\mathbf{X}, t) \\ \mathbf{x}' = \mathbf{f}(\mathbf{X}, t)\mathbf{X}' \end{pmatrix} \quad . \quad (10.26)$$

10.3.3 Basis systems on $\mathcal{R}_{\mathcal{R}}$, \mathcal{R}_t

As usually, the tangent space at any point of a manifold is defined to be an Euclidean vector space. The inner product in this space is denoted by a dot. Clearly, in the tangent space of every point there exist always an orthonormal basis, so that, with respect to this (perhaps local) basis, the components of the metric tensor will be given by the Kronecker delta symbol. If these bases form a field of coordinate basis vectors, tangent to a global coordinate system, then the metric coefficients of the metric on the manifold, will be given everywhere by the Kronecker delta symbol. In this case, the metric tensor on the manifold is everywhere the identity tensor of the second-order, and the manifold will be Euclidean. However, if it is not possible to select such a coordinate system, then the tangent vector spaces will be still Euclidean, but the metric of the manifold, and hence the manifold itself, will be not Euclidean. In this case, if we are given the metric coefficients at every point on the manifold, then there do not exist some coordinate transformations rendering the metric coefficients equal to the Kronecker delta everywhere. Nevertheless, the components of tensorial quantities will be expressed in terms of the Euclidean product, which holds always in the tangent space at every point.

We assume $\mathcal{R}_{\mathcal{R}}$ and \mathcal{R}_t to be Euclidean manifolds, and that they can be covered by coordinate lines of single coordinate systems, respectively. Let $\{X^i\}$, $\{x^i\}$ be Cartesian coordinate systems for $\mathcal{R}_{\mathcal{R}}$ and \mathcal{R}_t , inducing the coordinate bases $\mathbf{E}_i \equiv \mathbf{E}^i$, $\mathbf{e}_i \equiv \mathbf{e}^i$, respectively,

$$\mathbf{E}^i \cdot \mathbf{E}_j = \delta_j^i \quad , \quad \mathbf{e}^i \cdot \mathbf{e}_j = \delta_j^i \quad . \quad (10.27)$$

It is convenient to use the coordinate system $\{X^i\}$ as a convective one. Then the coordinate lines in $\mathcal{R}_{\mathcal{R}}$ of the coordinate system $\{X^i\}$ will represent material lines, which will be deformed in \mathcal{R}_t to form the coordinate lines in \mathcal{R}_t . To a material point, it will be assigned in $\mathcal{R}_{\mathcal{R}}$ and \mathcal{R}_t the same values of convective coordinates $\{X^i\}$, but the corresponding local coordinate basis will change. If \mathbf{E}_i and \mathbf{g}_i are the coordinate basis vectors for the same material point in $\mathcal{R}_{\mathcal{R}}$ and \mathcal{R}_t , respectively, then

$$\mathbf{g}_i = \mathbf{F}\mathbf{E}_i \quad , \quad \mathbf{g}^i = \mathbf{F}^{T-1}\mathbf{E}^i \quad , \quad \mathbf{g}^i \cdot \mathbf{g}_j = \delta_j^i \quad , \quad (10.28)$$

$$g_{ij} = \mathbf{g}_i \cdot \mathbf{g}_j = \mathbf{E}_i \cdot \mathbf{C}\mathbf{E}_j \quad , \quad g^{ij} = \mathbf{g}^i \cdot \mathbf{g}^j = \mathbf{E}^i \cdot \mathbf{C}^{-1}\mathbf{E}^j \quad , \quad (10.29)$$

where $\mathbf{C} := \mathbf{F}^T\mathbf{F}$ is the right Cauchy-Green deformation tensor. Between the two basis fields $\{\mathbf{e}_i\}$ and $\{\mathbf{g}_i\}$, assigned to the manifold \mathcal{R}_t , there are the relations

$$\mathbf{g}_j = \frac{\partial x^i}{\partial X^j} \mathbf{e}_i \quad , \quad \mathbf{g}^i = \frac{\partial X^i}{\partial x^j} \mathbf{e}^j \quad . \quad (10.30)$$

This, together with the formula $\mathbf{e}^k \frac{\partial}{\partial x^k} = \mathbf{e}^k \frac{\partial X^m}{\partial x^k} \frac{\partial}{\partial X^m}$, imply

$$\mathbf{e}^k \frac{\partial}{\partial x^k} = \mathbf{g}^m \frac{\partial}{\partial X^m} \quad . \quad (10.31)$$

Then,

$$\mathbf{F} = F_j^i \mathbf{e}_i \otimes \mathbf{E}^j = \delta_j^i \mathbf{g}_i \otimes \mathbf{E}^j \quad , \quad F_j^i \equiv F_{ij} = \frac{\partial x^i}{\partial X^j} \quad , \quad (10.32)$$

$$\mathbf{F}^{-1} = (\mathbf{F}^{-1})_j^i \mathbf{E}_i \otimes \mathbf{e}^j = \delta_j^i \mathbf{E}_i \otimes \mathbf{g}^j \quad , \quad (\mathbf{F}^{-1})_j^i \equiv (\mathbf{F}^{-1})_{ij} = \frac{\partial X^i}{\partial x^j} \quad . \quad (10.33)$$

In analogy to (10.28), (10.29), an additional basis field $\mathbf{q}_i = \mathbf{q}_i(\mathbf{x}, t)$ may be introduced on \mathcal{R}_t , by

$$\mathbf{q}_i := \mathbf{f}\mathbf{E}_i \quad , \quad \mathbf{q}^i := \mathbf{f}^{T-1}\mathbf{E}^i \quad , \quad \mathbf{q}^i \cdot \mathbf{q}_j = \delta_j^i \quad . \quad (10.34)$$

However, in opposite to $\{\mathbf{g}_i\}$, the basis $\{\boldsymbol{\varrho}_i\}$ is anholonomic, since \mathbf{f} does not satisfy some compatibility conditions with respect to the coordinates $\{X^i\}$. In other words, \mathbf{f} has to be viewed as a local deformation for the macroscopic body.

10.3.4 Micromorphic curvature tensors

Every micromorphic constitutive theory includes as state variables, beside strain tensors, micromorphic curvature tensors, like

$$\tilde{\mathcal{K}} := \mathbf{f}^{-1} \text{GRAD} \mathbf{f} \equiv \mathbf{f}^{-1} \frac{\partial \mathbf{f}}{\partial X^k} \otimes \mathbf{E}^k \quad . \quad (10.35)$$

The aim of our article is to elucidate geometrical aspects of the curvature tensor $\tilde{\mathcal{K}}$ with the help of a scalar difference defined as follows.

Suppose \mathcal{X}'_i , $i = 1, 2, 3$, to be mutually different material points of the microstructure attached at \mathcal{X} , which are not all in a plane, and are different than \mathcal{X} . Let $\boldsymbol{\Phi}_i = \boldsymbol{\Phi}_i(\mathbf{X})$ be fields of (position) vectors assigned to the pairs $(\mathcal{X}, \mathcal{X}'_i)$. Clearly, $\boldsymbol{\Phi}_i$ are three time- and linear independent vectors (directors) at \mathbf{X} ($\boldsymbol{\Phi}_i \in T_{\mathbf{X}} \mathcal{R}$), which form a basis at \mathbf{X} , the reciprocal basis being $\boldsymbol{\Phi}^i = \boldsymbol{\Phi}^i(\mathbf{X})$, $\boldsymbol{\Phi}^i \cdot \boldsymbol{\Phi}_j = \delta^i_j$. On the other hand, $\boldsymbol{\Phi}_i$ may be thought to be tangent vectors to material lines of the microstructure at \mathbf{X} . Then, the reduced convective basis for the microcontinuum at \mathbf{x} will be given by

$$\boldsymbol{\varphi}_i = \boldsymbol{\varphi}_i(\mathbf{x}, t) = \mathbf{f} \boldsymbol{\Phi}_i \in T_{\mathbf{x}} \mathcal{R}_t \quad (10.36)$$

with reciprocal basis

$$\boldsymbol{\varphi}^i = \boldsymbol{\varphi}^i(\mathbf{x}, t) = \mathbf{f}^{T-1} \boldsymbol{\Phi}^i \in T_{\mathbf{x}} \mathcal{R}_t \quad . \quad (10.37)$$

The basis fields $\boldsymbol{\varphi}_i(\mathbf{x}, t)$ and $\boldsymbol{\Phi}_i(\mathbf{X})$, induced by the convective coordinate systems in the microstructure, can be invoked to characterize the deformation of the microcontinuum. This stays in analogy to the macroscopic continuum, the deformation of which can be reflected by the basis vector fields $\mathbf{E}_i(\mathbf{X})$ and $\mathbf{g}_i(\mathbf{x}, t)$, induced by the convective coordinate system $\{X^i\}$.

Now, we define a scalar-valued difference Δ_c by

$$\Delta_c = \Delta_c(\mathbf{X}, t) := \boldsymbol{\varphi}^1 \cdot (\nabla_{\mathcal{R}_t} \boldsymbol{\varphi}_2)[\mathbf{g}_3] - \boldsymbol{\Phi}^1 \cdot (\nabla_{\mathcal{R}} \boldsymbol{\Phi}_2)[\mathbf{E}_3] \quad , \quad (10.38)$$

where

$$\nabla_{\mathcal{R}_t} \boldsymbol{\varphi}_2 := \text{grad} \boldsymbol{\varphi}_2 = \frac{\partial \boldsymbol{\varphi}_2}{\partial X^k} \otimes \mathbf{g}^k \quad , \quad (10.39)$$

$$\nabla_{\mathcal{R}} \boldsymbol{\Phi}_2 := \text{GRAD} \boldsymbol{\Phi}_2 = \frac{\partial \boldsymbol{\Phi}_2}{\partial X^k} \otimes \mathbf{E}^k \quad . \quad (10.40)$$

Δ_c is a measure for the deformation of the microstructure at a material point, which takes into account the deformation of the microstructure assigned to points in the neighborhood.

We shall prove that Δ_c may be represented form-invariantly by means of micromorphic curvature tensors. To this end, we express $\boldsymbol{\varphi}^1$, $\boldsymbol{\varphi}_2$ and \mathbf{g}_3 in Eq. (10.38) in terms of $\boldsymbol{\Phi}^1$, $\boldsymbol{\Phi}_2$ and \mathbf{E}_3 ,

$$\Delta_c = \mathbf{f}^{T-1} \boldsymbol{\Phi}^1 \cdot \left(\frac{\partial(\mathbf{f} \boldsymbol{\Phi}_2)}{\partial X^k} \otimes \mathbf{g}^k \right) [\mathbf{g}_3] - \boldsymbol{\Phi}^1 \cdot \left(\frac{\partial \boldsymbol{\Phi}_2}{\partial X^k} \otimes \mathbf{E}^k \right) [\mathbf{E}_3]$$

$$= \Phi^1 \cdot \left\{ \mathbf{f}^{-1} \frac{\partial \mathbf{f}}{\partial X^k} \Phi_2 \right\} (\mathbf{g}^k \cdot \mathbf{g}_3) + \Phi^1 \cdot \frac{\partial \Phi_2}{\partial X^k} (\mathbf{g}^k \cdot \mathbf{g}_3) - \Phi^1 \cdot \frac{\partial \Phi_2}{\partial X^k} (\mathbf{E}^k \cdot \mathbf{E}_3) \quad , \quad (10.41)$$

or, in view of $\mathbf{g}^k \cdot \mathbf{g}_3 = \mathbf{E}^k \cdot \mathbf{E}_3$,

$$\Delta_c = \Phi^1 \cdot \left(\mathbf{f}^{-1} \frac{\partial \mathbf{f}}{\partial X^k} \Phi_2 \right) (\mathbf{E}^k \cdot \mathbf{E}_3) = \left(\mathbf{f}^{-1} \frac{\partial \mathbf{f}}{\partial X^k} \otimes \mathbf{E}^k \right) [\Phi^1, \Phi_2, \mathbf{E}_3] \quad . \quad (10.42)$$

Hence,

$$\Delta_c = \tilde{\mathcal{K}}[\Phi^1, \Phi_2, \mathbf{E}_3] \quad . \quad (10.43)$$

It is straightforward to verify that, with respect to the actual configuration,

$$\Delta_c = \mathcal{K}[\varphi^1, \varphi_2, \mathbf{g}_3] \quad , \quad (10.44)$$

where

$$\mathcal{K} := \frac{\partial \mathbf{f}}{\partial X^k} \mathbf{f}^{-1} \otimes \mathbf{g}^k \equiv (\text{gradf}) \diamond \mathbf{f}^{-1} \quad (10.45)$$

and

$$\mathcal{K} = \mathcal{L}(\mathbf{f}, \mathbf{f}^{T-1}, \mathbf{F}^{T-1})[\tilde{\mathcal{K}}] \quad . \quad (10.46)$$

That means, \mathcal{K} can be derived from $\tilde{\mathcal{K}}$ by push-forward transformation generated by $\mathcal{L}(\mathbf{f}, \mathbf{f}^{T-1}, \mathbf{F}^{T-1})$.

More generally, one can invoke global or local (incompatible) regular linear transformations $\mathbf{F}_a = \mathbf{F}_a(\mathbf{X}, t)$ for the macroscopic continuum, and regular linear transformations $\mathbf{f}_a = \mathbf{f}_a(\mathbf{X}, t)$ for the microscopic continuum, both going from the reference to the same, but otherwise arbitrary configuration. On designating the counterparts of $\mathbf{E}_k, \mathbf{E}^k, \Phi_k, \Phi^k$ in this configuration, within the context of convective coordinates, by $(\mathbf{g}_a)_k, (\mathbf{g}_a)^k, (\varphi_a)_k, (\varphi_a)^k$,

$$(\mathbf{g}_a)_k := \mathbf{F}_a \mathbf{E}_k \quad , \quad (\mathbf{g}_a)^k = \mathbf{F}_a^{T-1} \mathbf{E}^k \quad , \quad (10.47)$$

$$(\varphi_a)_k := \mathbf{f}_a \Phi_k \quad , \quad (\varphi_a)^k = \mathbf{f}_a^{T-1} \Phi^k \quad , \quad (10.48)$$

an equivalence class of micromorphic curvature tensors \mathcal{K}_a can be constructed, such that

$$\Delta_c = \mathcal{K}_a[(\varphi_a)^1, (\varphi_a)_2, (\mathbf{g}_a)_3] \quad (10.49)$$

and

$$\mathcal{K}_a = \mathcal{L}(\mathbf{f}_a, \mathbf{f}_a^{T-1}, \mathbf{F}_a^{T-1})[\tilde{\mathcal{K}}] \quad (10.50)$$

or

$$\tilde{\mathcal{K}} = \mathcal{L}(\mathbf{f}_a^{-1}, \mathbf{f}_a^T, \mathbf{F}_a^T)[\mathcal{K}_a] \quad . \quad (10.51)$$

We conclude from Eqs. (10.43), (10.44) and (10.49), that the difference Δ_c is represented form-invariantly, with respect to the chosen configuration, by using appropriate micromorphic curvature tensors. Additionally, all micromorphic curvature tensors can be generated from $\tilde{\mathcal{K}}$ by push-forward transformations like Eq. (10.50). Especially, for $\mathbf{F}_a = \mathbf{F}$ and $\mathbf{f}_a = \mathbf{f}$,

$$\mathcal{K}_{mnr} = (\mathbf{f})_{mi} (\mathbf{f}^{T-1})_{nj} (\mathbf{F}^{T-1})_{rk} \tilde{\mathcal{K}}_{ijk} \quad , \quad (10.52)$$

$$\tilde{\mathcal{K}}_{mnr} = (\mathbf{f}^{-1})_{mi} (\mathbf{f}^T)_{nj} (\mathbf{F}^T)_{rk} \mathcal{K}_{ijk} \quad , \quad (10.53)$$

with respect to the Cartesian coordinate systems $\{X_i\}$ for $\mathcal{R}_{\mathcal{R}}$ and $\{x_i\}$ for \mathcal{R}_t . Obviously, $\tilde{\mathcal{K}}(\mathbf{X}, t)$ is a third-order tensor on $\mathcal{R}_{\mathcal{R}}$, $\mathcal{K}(\mathbf{x}, t)$ is a third-order tensor on \mathcal{R}_t , and so forth.

10.4 Decompositions of deformation

10.4.1 Multiplicative decomposition of the macro- and the microdeformation gradient tensors into elastic and plastic parts

As in classical plasticity, it is assumed that the macrodeformation gradient tensor \mathbf{F} may be decomposed into elastic and plastic parts,

$$\mathbf{F} = \mathbf{F}_e \mathbf{F}_p \quad , \quad (10.54)$$

where $\det \mathbf{F}_e > 0$ is assumed, and therefore $\det \mathbf{F}_p > 0$, in view of $\det \mathbf{F} > 0$. This decomposition of \mathbf{F} has been broadly known by the works [101] and [100]. Decomposition (10.54) is supposed to be unique except for a rigid body rotation (see, e.g., [78, 13, 14]). In addition to (10.54), we assume the multiplicative decomposition of the microdeformation gradient tensor \mathbf{f} into elastic and plastic parts,

$$\mathbf{f} = \mathbf{f}_e \mathbf{f}_p \quad , \quad (10.55)$$

with $\det \mathbf{f}_e > 0$, and therefore $\det \mathbf{f}_p > 0$ too. Decomposition (10.55) is supposed to be also unique except for the same rigid body rotation, which may be inserted into the decomposition (10.54).

In opposite to $\mathbf{F}(\mathbf{X}, t)$, $\mathbf{F}_p(\mathbf{X}, t)$ (and therefore $\mathbf{F}_e(\mathbf{X}, t)$ too) is incompatible deformation. For fixed time t , $\mathbf{F}_p(\mathbf{X}, t)$ induces a local configuration for the macroscopic continuum at \mathbf{X} . (We adopt the definition of local deformation and local configuration used in [129] and [155].) Let $\hat{\mathbf{x}} \in \mathcal{E}$ be, in that local configuration, the position vector of the material point of the macroscopic continuum which in the reference configuration posses the position vector \mathbf{X} . Obviously, the position $\hat{\mathbf{x}}$ can be chosen arbitrary (cf. [72]). This fact may be visualized by imaging the local deformation $\mathbf{F}_p(\mathbf{X}, t)$ at \mathbf{X} to map a neighborhood $\mathcal{N}(\mathbf{X}) \in \mathcal{E}$ on a neighborhood $\hat{\mathcal{M}}(\hat{\mathbf{x}}, t) \in \mathcal{E}$ around $\hat{\mathbf{x}}$, with $\hat{\mathbf{x}}$ being arbitrary point of \mathcal{E} . We assume in particular $\hat{\mathbf{x}}$ to be given by an arbitrary deformation $\hat{\chi}$,

$$\hat{\mathbf{x}} = \hat{\chi}(\mathbf{X}, t) \quad . \quad (10.56)$$

It is emphasized that $\mathbf{F}_p(\mathbf{X}, t) \neq \frac{\partial \hat{\chi}}{\partial \mathbf{X}}$ generally. As special cases, $\hat{\mathbf{x}} \equiv \mathbf{X}$ or $\hat{\mathbf{x}} \equiv \mathbf{x}$ are allowed. In the following, the conceptual configuration introduced by deformation $\hat{\chi}(\cdot, t)$ is left arbitrary. We shall write \hat{R}_t for the range in \mathcal{E} occupied by the macroscopic body under the configuration induced by $\hat{\chi}$, $\hat{R}_t = \hat{\chi}(\mathcal{R}_{\mathcal{R}}, t)$. Since \mathbf{F}_p represents a local deformation, for given neighborhood $\mathcal{N}(\mathbf{X}) \in \mathcal{E}$, $\mathbf{X} \in \mathcal{R}_{\mathcal{R}}$, there exist deformations $\hat{\mu}_{\mathbf{X}}(\cdot, t)$, which map $\mathcal{N}(\mathbf{X})$ on neighborhoods $\hat{\mathcal{M}}(\hat{\mathbf{x}}, t) \subset \mathcal{E}$, with

$$\hat{\mu}_{\mathbf{X}} : \mathcal{N}(\mathbf{X}) \times I \rightarrow \hat{\mathcal{M}}(\hat{\mathbf{x}}, t) := \hat{\mu}_{\mathbf{X}}(\mathcal{N}(\mathbf{X}), t) \quad , \quad (10.57)$$

$$\hat{\mu}_{\mathbf{X}}(\mathbf{X}, t) = \hat{\mathbf{x}} = \hat{\chi}(\mathbf{X}, t) \in \hat{R}_t \quad , \quad (10.58)$$

$$\mathbf{M}_{\mathbf{X}}(\mathbf{Y}, t) := \frac{\partial \hat{\mu}_{\mathbf{X}}(\mathbf{Y}, t)}{\partial \mathbf{Y}} \quad , \quad \mathbf{M}_{\mathbf{X}}(\mathbf{Y}, t)|_{\mathbf{Y}=\mathbf{X}} = \mathbf{F}_p(\mathbf{X}, t) \quad . \quad (10.59)$$

For later reference, we introduce the notation

$$\frac{\partial \mathbf{M}_{\mathbf{X}}}{\partial \mathbf{Y}} \Big|_{\mathbf{Y}=\mathbf{X}} \equiv \frac{\partial^2 \hat{\mu}_{\mathbf{X}}}{\partial \mathbf{Y} \partial \mathbf{Y}} \Big|_{\mathbf{Y}=\mathbf{X}} = \mathcal{P}(\mathbf{X}, t) = \mathcal{P}^i_{jl} \hat{\mathbf{e}}_i \otimes \mathbf{E}^j \otimes \mathbf{E}^l \quad , \quad \mathcal{P}^i_{lj} = \mathcal{P}^i_{jl} \equiv \mathcal{P}_{ijl} \quad . \quad (10.60)$$

Here, $\{\mathbf{E}^i\} \equiv \{\mathbf{E}_i\}$ and $\{\hat{\mathbf{e}}^i\} \equiv \{\hat{\mathbf{e}}_i\}$ are the coordinate bases respectively to Cartesian coordinate systems $\{X^i\} \equiv \{X_i\}$ and $\{\hat{x}^i\} \equiv \{\hat{x}_i\}$ in \mathcal{E} , so that $\mathbf{X} = X_i \mathbf{E}_i$ and $\hat{\mathbf{x}} = \hat{x}_i \hat{\mathbf{e}}_i$. Configuration $\hat{\chi}(\cdot, t)$,

together with a collection of local deformations (10.57)–(10.60) is referred to as plastic intermediate configuration for the macroscopic continuum. As the position vector $\hat{\mathbf{x}}$ may be chosen arbitrary, we shall say that the macroscopic continuum will deform in the plastic intermediate configuration locally by \mathbf{F}_p . While the macroscopic continuum deforms locally from \mathbf{X} to $\hat{\mathbf{x}}$, the microscopic continuum at \mathbf{X} is postulated to deform homogeneously by $\mathbf{f}_p = \mathbf{f}_p(\mathbf{X}, t)$, so that the position vector \mathbf{X}' , emanated from point $\mathbf{X} \in \mathcal{R}_R$, will go to the position vector $\hat{\mathbf{x}}' = \hat{\chi}'(\mathbf{X}, \mathbf{X}', t) = \mathbf{f}_p(\mathbf{X}, t)\mathbf{X}'$, emanated from point $\hat{\mathbf{x}} \in \hat{R}_t$. This way, the range $\mathcal{R}'_R(\mathbf{X})$ will be mapped on the range $\hat{R}'_t(\hat{\mathbf{x}}) = \hat{\chi}'(\mathbf{X}, \mathcal{B}', t)$. For fixed t , we refer to $\hat{\chi}'(\mathbf{X}, \cdot, t)$ as the plastic intermediate configuration of the microscopic continuum at \mathbf{X} . The plastic intermediate configuration for the macroscopic continuum together with that one for the microscopic continuum are called plastic intermediate configuration for the micromorphic continuum. Clearly, \mathbf{F}_p and \mathbf{f}_p , and therefore \mathbf{F}_e and \mathbf{f}_e too, are two-point tensor fields.

10.4.2 Basis systems on \hat{R}_t

Before going any further, it is convenient to introduce some special basis systems. In conjunction with the basis systems $\{\mathbf{g}_i\}$, $\{\mathbf{E}_i\}$ (cf. Sect. 10.3.3), we define

$$\hat{\mathbf{g}}_i := \mathbf{F}_p \mathbf{E}_i \quad , \quad \hat{\mathbf{g}}^i = \mathbf{F}_p^{T-1} \mathbf{E}^i \quad , \quad \hat{\mathbf{g}}^i \cdot \hat{\mathbf{g}}_j = \delta^i_j \quad , \quad (10.61)$$

so that

$$\mathbf{g}_i = \mathbf{F}_e \hat{\mathbf{g}}_i \quad , \quad \mathbf{g}^i = \mathbf{F}_e^{T-1} \hat{\mathbf{g}}^i \quad . \quad (10.62)$$

Additionally, we set

$$\mathbf{F}_p = (\mathbf{F}_p)^i_j \hat{\mathbf{e}}_i \otimes \mathbf{E}^j \quad , \quad (\mathbf{F}_p)^i_j \equiv (\mathbf{F}_p)_{ij} \quad , \quad (10.63)$$

$$\mathbf{F}_p^{-1} = (\mathbf{F}_p^{-1})^i_j \mathbf{E}_i \otimes \hat{\mathbf{e}}^j \quad , \quad (\mathbf{F}_p^{-1})^i_j \equiv (\mathbf{F}_p^{-1})_{ij} \quad . \quad (10.64)$$

It follows that

$$\hat{\mathbf{g}}_i := (\mathbf{F}_p)^j_i \hat{\mathbf{e}}_j \quad , \quad \hat{\mathbf{g}}^i := (\mathbf{F}_p^{-1})^i_j \hat{\mathbf{e}}^j \quad . \quad (10.65)$$

In conjunction with basis $\{\varrho_i\}$ (cf. Sect. 10.3.3), one may introduce a further basis $\{\hat{\rho}_i\}$ at $\hat{\mathbf{x}}$, by

$$\hat{\rho}_i := \mathbf{f}_p \mathbf{E}_i \quad , \quad \hat{\rho}^i := \mathbf{f}_p^{T-1} \mathbf{E}^i \quad , \quad \hat{\rho}^i \cdot \hat{\rho}_j = \delta^i_j \quad . \quad (10.66)$$

Similar to (10.63), (10.64), we set

$$\mathbf{f}_p = (\mathbf{f}_p)^i_j \hat{\mathbf{e}}_i \otimes \mathbf{E}^j \quad , \quad (\mathbf{f}_p)^i_j \equiv (\mathbf{f}_p)_{ij} \quad , \quad (10.67)$$

$$\mathbf{f}_p^{-1} = (\mathbf{f}_p^{-1})^i_j \mathbf{E}_i \otimes \hat{\mathbf{e}}^j \quad , \quad (\mathbf{f}_p^{-1})^i_j \equiv (\mathbf{f}_p^{-1})_{ij} \quad , \quad (10.68)$$

and hence

$$\hat{\rho}_i = (\mathbf{f}_p)^j_i \hat{\mathbf{e}}_j \quad , \quad \hat{\rho}^i = (\mathbf{f}_p^{-1})^i_j \hat{\mathbf{e}}^j \quad . \quad (10.69)$$

The transformation law between $\{\hat{\mathbf{g}}_i\}$ and $\{\hat{\rho}_i\}$ reads

$$\hat{\mathbf{g}}_i = A^j_i \hat{\rho}_j \quad , \quad \hat{\mathbf{g}}^i = (A^{-1})^i_j \hat{\rho}^j \quad , \quad (10.70)$$

with

$$A_j^i = (\mathbf{f}_p^{-1})^i_r (\mathbf{F}_p)^r_j \quad , \quad (A^{-1})^i_j = (\mathbf{F}_p^{-1})^i_r (\mathbf{f}_p)^r_j \quad , \quad (10.71)$$

$$(A^{-1})^i_r A_j^r = A^i_r (A^{-1})^r_j = \delta_j^i \quad . \quad (10.72)$$

Let $\{X^i\}$ be extended to the whole space \mathcal{E} , so that $\mathcal{N}(\mathbf{X})$ is covered by coordinate lines X^i . Regard these to be convective coordinate lines for $\hat{\mathcal{M}}(\hat{\mathbf{x}}, t)$, with coordinate basis $\{(\hat{\nu}_{\mathbf{X}})_i\}$,

$$\hat{\mathbf{y}} = \hat{\boldsymbol{\mu}}_{\mathbf{X}}(\mathbf{Y}, t) \quad , \quad \mathbf{Y} = Y^i \mathbf{E}_i \in \mathcal{N}(\mathbf{X}) \quad , \quad (10.73)$$

$$(\hat{\nu}_{\mathbf{X}})_i = (\hat{\nu}_{\mathbf{X}})_i(\hat{\mathbf{y}}, t) := \mathbf{M}_{\mathbf{X}}(\mathbf{Y}, t)[\mathbf{E}_i] \quad , \quad (10.74)$$

$$(\hat{\nu}_{\mathbf{X}})^i = (\hat{\nu}_{\mathbf{X}})^i(\hat{\mathbf{y}}, t) := \mathbf{M}_{\mathbf{X}}^{T-1}(\mathbf{Y}, t)[\mathbf{E}^i] \quad , \quad (10.75)$$

where

$$\mathbf{M}_{\mathbf{X}} = (\mathbf{M}_{\mathbf{X}})^i_j \hat{\mathbf{e}}_i \otimes \mathbf{E}^j \quad , \quad \mathbf{M}_{\mathbf{X}}^{-1} = (\mathbf{M}_{\mathbf{X}}^{-1})^i_j \mathbf{E}_i \otimes \hat{\mathbf{e}}^j \quad . \quad (10.76)$$

Then,

$$(\hat{\nu}_{\mathbf{X}})_i|_{\hat{\mathbf{y}}=\hat{\mathbf{x}}} = \mathbf{F}_p(\mathbf{X}, t)\mathbf{E}_i = \hat{\mathbf{g}}_i \quad , \quad (10.77)$$

$$(\hat{\nu}_{\mathbf{X}})^i|_{\hat{\mathbf{y}}=\hat{\mathbf{x}}} = \mathbf{F}_p^{T-1}(\mathbf{X}, t)\mathbf{E}^i = \hat{\mathbf{g}}^i \quad . \quad (10.78)$$

10.4.3 Additive decomposition of Δ_c

We set $\mathbf{F}_a = \mathbf{F}_p$, $\mathbf{f}_a = \mathbf{f}_p$, $\mathcal{K}_a = \hat{\mathcal{K}}$, $(\mathbf{g}_a)_k = \hat{\mathbf{g}}_k$, $(\varphi_a)_k = \hat{\varphi}_k$, so that

$$\hat{\mathbf{g}}_k = \mathbf{F}_p \mathbf{E}_k = \mathbf{F}_e^{-1} \mathbf{g}_k \quad , \quad \hat{\mathbf{g}}^k = \mathbf{F}_p^{T-1} \mathbf{E}^k = \mathbf{F}_e^T \mathbf{g}^k \quad , \quad (10.79)$$

$$\hat{\varphi}_k = \mathbf{f}_p \Phi_k = \mathbf{f}_e^{-1} \varphi_k \quad , \quad \hat{\varphi}^k = \mathbf{f}_p^{T-1} \Phi^k = \mathbf{f}_e^T \varphi^k \quad . \quad (10.80)$$

This suggests additive decomposition of Δ_c into elastic, $(\Delta_c)_e$, and plastic, $(\Delta_c)_p$, parts,

$$\Delta_c = \varphi^1 \cdot (\nabla_{\mathcal{R}_t} \varphi_2)[\mathbf{g}_3] - \Phi^1 \cdot (\nabla_{\mathcal{R}_R} \Phi_2)[\mathbf{E}_3] = (\Delta_c)_e + (\Delta_c)_p \quad , \quad (10.81)$$

with

$$(\Delta_c)_e := \varphi^1 \cdot (\nabla_{\mathcal{R}_t} \varphi_2)[\mathbf{g}_3] - \hat{\varphi}^1 \cdot (\nabla_{\hat{\mathcal{R}}_t} \hat{\varphi}_2)[\hat{\mathbf{g}}_3] \quad , \quad (10.82)$$

$$(\Delta_c)_p := \hat{\varphi}^1 \cdot (\nabla_{\hat{\mathcal{R}}_t} \hat{\varphi}_2)[\hat{\mathbf{g}}_3] - \Phi^1 \cdot (\nabla_{\mathcal{R}_R} \Phi_2)[\mathbf{E}_3] \quad . \quad (10.83)$$

Constitutive aspects of the underlying physic of plasticity may be addressed appropriately by using suitable differential operators $\nabla_{\hat{\mathcal{R}}_t}$. In the case of micropolar plasticity, a so-called relative covariant derivative has been proposed in [72] as a possibility. Here, we shall extent the approach of [72], by defining a relative covariant derivative for micromorphic continua. We do this in two steps, by introducing first a so-called relative gradient and then a relative covariant derivative on $\hat{\mathcal{R}}_t$.

10.5 Spatial differential operators on $\hat{\mathcal{R}}_t$

10.5.1 Relative gradient on $\hat{\mathcal{R}}_t$

Let $\mathbf{b} = \mathbf{b}(\mathbf{x}, t) \in T_{\mathbf{x}}\mathcal{R}_t$ be an Eulerian vector field. Then,

$$\text{grad} \mathbf{b} = (\text{GRAD} \mathbf{b}) \mathbf{F}^{-1} \quad . \quad (10.84)$$

According to Noll [129] (cf. also [155]), this equation suggests to introduce relative gradients $\bar{\nabla}_{\Psi}\mathbf{b}$ (relative to the current configuration), related to local (incompatible) deformation fields $\Psi(\mathbf{X}, t) : T_{\mathbf{X}}\mathcal{R}_{\mathcal{R}} \rightarrow T_{\mathbf{x}}\mathcal{R}_t$, by

$$\bar{\nabla}_{\Psi}\mathbf{b} := (\text{GRAD}\mathbf{b})\Psi^{-1} \quad . \quad (10.85)$$

Evidently, if $\hat{\mathbf{b}} = \hat{\mathbf{b}}(\hat{\mathbf{x}}, t) \in T_{\hat{\mathbf{x}}}\hat{R}_t$ is a vector field on \hat{R}_t , then, by applying definition (10.85) on the plastic intermediate configuration, we can define a relative gradient on \hat{R}_t by

$$\hat{\nabla}_p\hat{\mathbf{b}} := (\text{GRAD}\hat{\mathbf{b}})\mathbf{F}_p^{-1} \quad . \quad (10.86)$$

To gain the components of $\hat{\nabla}_p\hat{\mathbf{b}}$ relative to the basis $\{\hat{\rho}_i \otimes \hat{\mathbf{g}}^j\}$, we set

$$\hat{\mathbf{b}} = b^m \hat{\rho}_m = \hat{b}^n \hat{\mathbf{g}}_n \in T_{\hat{\mathbf{x}}}\hat{R}_t \quad , \quad \hat{b}^n = (A^{-1})^n_m b^m \quad . \quad (10.87)$$

Keeping in mind (10.69),

$$\frac{\partial \hat{\rho}_m}{\partial X^i} = (\mathbf{f}_p^{-1})^j_n \frac{\partial (\mathbf{f}_p)^n_m}{\partial X^i} \hat{\rho}_j \quad , \quad (10.88)$$

and after substituting in Eq. (10.86)

$$\hat{\nabla}_p\hat{\mathbf{b}} = \left(\frac{\partial \hat{\mathbf{b}}}{\partial X^i} \otimes \mathbf{E}^i \right) \mathbf{F}_p^{-1} = \frac{\partial \hat{\mathbf{b}}}{\partial X^i} \otimes \hat{\mathbf{g}}^i = \frac{\partial b^m}{\partial X^i} \hat{\rho}_m \otimes \hat{\mathbf{g}}^i + (\mathbf{f}_p^{-1})^j_n \frac{\partial (\mathbf{f}_p)^n_m}{\partial X^i} b^m \hat{\rho}_j \otimes \hat{\mathbf{g}}^i \quad , \quad (10.89)$$

or

$$\hat{\nabla}_p\hat{\mathbf{b}} = \left(\frac{\partial b^j}{\partial X^i} + (\Lambda_{\mathbf{f}_p})^j_{im} b^m \right) \hat{\rho}_j \otimes \hat{\mathbf{g}}^i \quad (10.90)$$

with

$$(\Lambda_{\mathbf{f}_p})^j_{im} := (\mathbf{f}_p^{-1})^j_n \frac{\partial (\mathbf{f}_p)^n_m}{\partial X^i} \quad . \quad (10.91)$$

It is worth remarking, that the basis $\{\hat{\rho}_i\}$ is anholonomic, its objects of anholonomy $(\hat{\mathcal{C}})^s_{rm}$ (see [141], p. 100) reading

$$(\hat{\mathcal{C}})^s_{rm} = (\mathbf{f}_p^{-1})^s_k \left((\mathbf{f}_p)^n_r \frac{\partial (\mathbf{f}_p)^k_m}{\partial \hat{x}^n} - (\mathbf{f}_p)^n_m \frac{\partial (\mathbf{f}_p)^k_r}{\partial \hat{x}^n} \right) \quad . \quad (10.92)$$

The basis $\{\hat{\mathbf{g}}_i\}$ is anholonomic too, its anholonomy objects being as in the last equation, but with \mathbf{f}_p replaced by \mathbf{F}_p . Moreover, as outlined in [72], relative gradients related to incompatible deformations, like $\hat{\nabla}_p\hat{\mathbf{b}}$, are not covariant derivatives. However, they can be put into relation to some covariant derivatives, as it is shown below.

10.5.2 Relative gradient as transformed covariant derivative

One way to relate $\hat{\nabla}_p\hat{\mathbf{b}}$ to a covariant derivative arises from the very definition (10.86), from which it can be recognized, that $\hat{\nabla}_p\hat{\mathbf{b}}$ is immediately related to $\text{GRAD}\hat{\mathbf{b}}$, the operator GRAD introducing a

covariant derivative in $\mathcal{R}\mathcal{R}$. However, $\hat{\mathbf{b}}(\hat{\mathbf{x}}, t)$ does not belong to the tangent space $T_{\mathbf{X}}\mathcal{R}\mathcal{R}$. Therefore, we consider the Lagrangean vector field

$$\mathbf{B} = (\mathbf{f}_p^{-1})\hat{\mathbf{b}} = b^i \mathbf{E}_i \in T_{\mathbf{X}}\mathcal{R}\mathcal{R} \quad , \quad (10.93)$$

so that, from (10.89)

$$\begin{aligned} \hat{\nabla}_p \hat{\mathbf{b}} &= \left(\frac{\partial \hat{\mathbf{b}}}{\partial X^i} \otimes \mathbf{E}^i \right) \mathbf{F}_p^{-1} \\ &= \mathbf{f}_p \left(\frac{\partial \mathbf{B}}{\partial X^i} \otimes \mathbf{E}^i + (\mathbf{f}_p^{-1}) \frac{\partial \mathbf{f}_p}{\partial X^i} \mathbf{B} \otimes \mathbf{E}^i \right) \mathbf{F}_p^{-1} \\ &= \mathbf{f}_p \left\{ \left(\frac{\partial b^j}{\partial X^i} + (\Lambda_{\mathbf{f}_p})^j_{ik} b^k \right) \mathbf{E}_j \otimes \mathbf{E}^i \right\} \mathbf{F}_p^{-1} \quad , \end{aligned} \quad (10.94)$$

with $(\Lambda_{\mathbf{f}_p})^j_{ik}$ as given in Eq. (10.91). The term enclosed in curls is a covariant derivative of \mathbf{B} in the space $\mathcal{R}\mathcal{R}$, with $(\Lambda_{\mathbf{f}_p})^j_{ik}$ being, with respect to $\{\mathbf{E}_i\}$, the objects of connection for $\mathcal{R}\mathcal{R}$. On defining

$$\tilde{\nabla} \mathbf{B} := \left(\frac{\partial b^j}{\partial X^i} + (\Lambda_{\mathbf{f}_p})^j_{il} b^l \right) \mathbf{E}_j \otimes \mathbf{E}^i \quad , \quad (10.95)$$

we conclude that

$$\hat{\nabla}_p \hat{\mathbf{b}} = \mathbf{f}_p(\tilde{\nabla} \mathbf{B}) \mathbf{F}_p^{-1} \quad . \quad (10.96)$$

This asserts, that the relative gradient $\hat{\nabla}_p \hat{\mathbf{b}}$ can be generated from the covariant derivative $\tilde{\nabla} \mathbf{B}$ by push-forward transformation of the latter through $\mathbf{f}_p(\cdot) \mathbf{F}_p^{-1}$.

Objects like $(\Lambda_{\mathbf{f}_p})^j_{im}$ in Eq. (10.91) have been often regarded as objects of connection for a manifold (see, e.g., [9, 129, 99, 120, 27, 96]). It has been argued that such objects of connection are not torsion-free. In fact, after inserting Eq. (10.91) into Eq. (10.132) in Sect. 10.8, and taking into account that the anholonomy objects for $\{\mathbf{E}_i\}$ are vanishing, we obtain the components of the torsion tensor \mathcal{T} (of the connection for $\mathcal{R}\mathcal{R}$ with symbols $(\Lambda_{\mathbf{f}_p})^j_{im}$), relative to the coordinate basis $\{\mathbf{E}_i\}$,

$$\mathcal{T}^j_{im} = (\mathbf{f}_p^{-1})^j_k \left(\frac{\partial (\mathbf{f}_p)^k_m}{\partial X^i} - \frac{\partial (\mathbf{f}_p)^k_i}{\partial X^m} \right) \quad , \quad (10.97)$$

which are non-vanishing in general. Hence, the connection is non-torsion-free. Moreover, it is an immediate consequence of Eq. (10.135) in Sect. 10.8, that the Riemannian curvature tensor of that connection vanishes,

$$\begin{aligned} \mathcal{R}^r_{ijm} &:= \frac{\partial}{\partial X^j} \left\{ (\mathbf{f}_p^{-1})^r_s \frac{\partial (\mathbf{f}_p)^s_i}{\partial X^m} \right\} - \frac{\partial}{\partial X^m} \left\{ (\mathbf{f}_p^{-1})^r_s \frac{\partial (\mathbf{f}_p)^s_i}{\partial X^j} \right\} \\ &\quad + (\mathbf{f}_p^{-1})^r_s \frac{\partial (\mathbf{f}_p)^s_p}{\partial X^j} (\mathbf{f}_p^{-1})^p_q \frac{\partial (\mathbf{f}_p)^q_i}{\partial X^m} - (\mathbf{f}_p^{-1})^r_s \frac{\partial (\mathbf{f}_p)^s_p}{\partial X^m} (\mathbf{f}_p^{-1})^p_q \frac{\partial (\mathbf{f}_p)^q_i}{\partial X^j} = 0 \quad . \end{aligned} \quad (10.98)$$

That means, the space $\mathcal{R}\mathcal{R}$ endowed with connection $(\Lambda_{\mathbf{f}_p})^j_{im}$, relative to $\{\mathbf{E}_i\}$, is flat.

Now, let $\hat{\mathbf{a}}(\hat{\mathbf{x}}, t)$, $\hat{\mathbf{c}}(\hat{\mathbf{x}}, t) \in T_{\hat{\mathbf{x}}}\hat{R}_t$ be two arbitrary vector fields on \hat{R}_t , and $\mathbf{A} := \mathbf{f}_p^{-1}\hat{\mathbf{a}}$, $\mathbf{C} := \mathbf{f}_p^{-1}\hat{\mathbf{c}}$ corresponding Lagrangean counterparts. Then,

$$\hat{\mathbf{g}}(\hat{\mathbf{a}}, \hat{\mathbf{c}}) := \hat{\mathbf{a}} \cdot \hat{\mathbf{c}} = \hat{\mathbf{a}} \cdot \mathbf{1} \hat{\mathbf{c}} \quad (10.99)$$

defines the Euclidean metric on \hat{R}_t , and $\tilde{\mathbf{G}}(\mathbf{A}, \mathbf{C}) := \hat{\mathbf{g}}(\hat{\mathbf{a}}, \hat{\mathbf{c}}) = \mathbf{A} \cdot (\mathbf{f}_p^T \mathbf{f}_p) \mathbf{C}$ defines a non-Euclidean metric on $\mathcal{R}_{\mathcal{R}}$. Indeed, $\mathbf{f}_p^T \mathbf{f}_p$ is symmetric and positive definite. The components of $\tilde{\mathbf{G}}$ with respect to $\{\mathbf{E}_i\}$ are

$$\tilde{G}_{ij} = (\mathbf{f}_p)_i^k \delta_{kl} (\mathbf{f}_p)_j^l = \hat{\boldsymbol{\rho}}_i \cdot \hat{\boldsymbol{\rho}}_j \quad . \quad (10.100)$$

Since $(\mathbf{f}_p)_i^k$ is not a Jacobian matrix attributed to a change of coordinates in $\mathcal{R}_{\mathcal{R}}$, there does not exist a global coordinate system, so that the components of $\tilde{\mathbf{G}}$ may be expressed by the Kronecker delta relative to that system. Consequently, $\tilde{\mathbf{G}}$ introduces a non-Euclidean metric on $\mathcal{R}_{\mathcal{R}}$. Additionally, with respect to the metric $\tilde{\mathbf{G}}$, the connection is metrical. This can be verified by using Eqs. (10.100), (10.91) into (10.134),

$$\begin{aligned} -\mathcal{Q}_{lki} &= \frac{\partial[(\mathbf{f}_p)_i^m \delta_{mn} (\mathbf{f}_p)_k^n]}{\partial X^l} - (\Lambda_{\mathbf{f}_p})_{li}^m (\mathbf{f}_p)_m^n \delta_{nr} (\mathbf{f}_p)_k^r - (\Lambda_{\mathbf{f}_p})_{lk}^m (\mathbf{f}_p)_i^n \delta_{nr} (\mathbf{f}_p)_m^r \\ &= \frac{\partial(\mathbf{f}_p)_i^m}{\partial X^l} \delta_{mn} (\mathbf{f}_p)_k^n + (\mathbf{f}_p)_i^m \delta_{mn} \frac{\partial(\mathbf{f}_p)_k^n}{\partial X^l} \\ &\quad - (\mathbf{f}_p^{-1})_s^m \frac{\partial(\mathbf{f}_p)_i^s}{\partial X^l} (\mathbf{f}_p)_m^n \delta_{nr} (\mathbf{f}_p)_k^r - (\mathbf{f}_p^{-1})_s^m \frac{\partial(\mathbf{f}_p)_k^s}{\partial X^l} (\mathbf{f}_p)_i^n \delta_{nr} (\mathbf{f}_p)_m^r = 0 \quad . \end{aligned} \quad (10.101)$$

Summarizing, the space $\mathcal{R}_{\mathcal{R}}$ may be viewed as flat, non-Euclidean and non-Riemannian manifold, endowed with the metric tensor field $\tilde{\mathbf{G}}$, and a metrical but non-symmetric connection, with objects $(\Lambda_{\mathbf{f}_p})_{jm}^i$ relative to the basis $\{\mathbf{E}_i\}$. Attention to non-Euclidean and non-Riemannian manifolds has been drawn for the first time by Kondo [94].

10.5.3 Relative gradient – relation to local deformations

We investigate the conditions under which the relative gradient $\hat{\nabla}_p \hat{\mathbf{b}}$ might be related to a covariant derivative, referred to a local deformation for the macroscopic continuum caused by \mathbf{F}_p . Let $\hat{\mathbf{b}}$ be given as in Eq. (10.87), and consider a "local" vector field $\hat{\mathbf{b}}_{\mathbf{X}}$ on $\hat{\mathcal{M}}(\hat{\mathbf{x}}, t)$, with (cf. Sect. 10.4.2)

$$\hat{\mathbf{b}}_{\mathbf{X}}(\hat{\mathbf{y}}, t) = (\hat{\mathbf{b}}_{\mathbf{X}})^i (\hat{\boldsymbol{\nu}}_{\mathbf{X}})_i \in T_{\hat{\mathbf{y}}} \hat{\mathcal{M}}(\hat{\mathbf{x}}, t) \quad (10.102)$$

and

$$\hat{\mathbf{b}}_{\mathbf{X}}|_{\hat{\mathbf{y}}=\hat{\mathbf{x}}} = \hat{\mathbf{b}}(\hat{\mathbf{x}}, t) \quad , \quad (10.103)$$

$$\left. \frac{\partial \hat{\mathbf{b}}_{\mathbf{X}}}{\partial Y^i} \right|_{\hat{\mathbf{y}}=\hat{\mathbf{x}}} = \frac{\partial \hat{\mathbf{b}}}{\partial X^i} \quad . \quad (10.104)$$

It follows that (cf. Eqs. (10.77), (10.89)₂)

$$\left. \frac{\partial \hat{\mathbf{b}}_{\mathbf{X}}}{\partial \hat{\mathbf{y}}} \right|_{\hat{\mathbf{y}}=\hat{\mathbf{x}}} \equiv \left. \frac{\partial \hat{\mathbf{b}}_{\mathbf{X}}}{\partial Y^i} \otimes (\hat{\boldsymbol{\nu}}_{\mathbf{X}})^i \right|_{\hat{\mathbf{y}}=\hat{\mathbf{x}}} = \frac{\partial \hat{\mathbf{b}}}{\partial X^i} \otimes \hat{\mathbf{g}}^i \equiv \hat{\nabla}_p \hat{\mathbf{b}} \quad , \quad (10.105)$$

where $\frac{\partial \hat{\mathbf{b}}_{\mathbf{X}}}{\partial \hat{\mathbf{y}}}$ is the gradient of $\hat{\mathbf{b}}_{\mathbf{X}}$ on $\hat{\mathcal{M}}(\hat{\mathbf{x}}, t)$, and therefore it represents a covariant derivative on $\hat{\mathcal{M}}(\hat{\mathbf{x}}, t)$ of the local vector field $\hat{\mathbf{b}}_{\mathbf{X}}$. In other words, if conditions like (10.103), (10.104) are fulfilled, then the relative gradient $\hat{\nabla}_p \hat{\mathbf{b}}$ may be related to the gradient of the local vector fields $\hat{\mathbf{b}}_{\mathbf{X}}$.

10.5.4 Relative covariant derivative on \hat{R}_t

Instead of the special connection $(\Lambda_{\mathbf{f}_p})^j_{il}$, one might employ an arbitrary connection Λ^j_{ik} in Eq. (10.95), in order to define a general covariant derivative $\tilde{\nabla}\mathbf{B}$ on $\mathcal{R}_{\mathcal{R}}$,

$$\tilde{\nabla}\mathbf{B} := \left(\frac{\partial b^j}{\partial X^i} + \Lambda^j_{il} b^l \right) \mathbf{E}_j \otimes \mathbf{E}^i \quad . \quad (10.106)$$

After push-forward transformation according to Eq. (10.96),

$$\hat{\nabla}\hat{\mathbf{b}} := \mathbf{f}_p(\tilde{\nabla}\mathbf{B})\mathbf{F}_p^{-1} = \left(\frac{\partial b^j}{\partial X^i} + \Lambda^j_{il} b^l \right) \hat{\rho}_j \otimes \hat{\mathbf{g}}^i \quad . \quad (10.107)$$

As before, Λ^j_{il} does not introduce a connection on \hat{R}_t , and $\hat{\nabla}\hat{\mathbf{b}}$ is not a covariant derivative of $\hat{\mathbf{b}}$, it is just the push-forward transformation of the covariant derivative $\tilde{\nabla}\mathbf{B}$. We shall call $\hat{\nabla}\hat{\mathbf{b}}$ relative covariant derivative of $\hat{\mathbf{b}}$ on \hat{R}_t , the relative gradient being a particular case of that.

The relative covariant derivative can be related to some other covariant derivatives, associated with local deformations. To make this more precise, we start from Eqs. (10.102), (10.74)–(10.78) take into account (10.59), (10.60), (10.87), (10.70)–(10.72), and form the derivative

$$\begin{aligned} \left. \frac{\partial \hat{\mathbf{b}}_{\mathbf{X}}}{\partial Y^i} \right|_{\hat{\mathbf{y}}=\hat{\mathbf{x}}} &= \left\{ \left(\frac{\partial (\hat{\mathbf{b}}_{\mathbf{X}})^j}{\partial Y^i} + (\mathbf{M}_{\mathbf{X}}^{-1})^j_n \frac{\partial (\mathbf{M}_{\mathbf{X}}^n)_m}{\partial Y^i} (\hat{\mathbf{b}}_{\mathbf{X}})^m \right) (\hat{\nu}_{\mathbf{X}})_j \right\}_{\hat{\mathbf{y}}=\hat{\mathbf{x}}} \\ &= \left\{ \left. \frac{\partial (\hat{\mathbf{b}}_{\mathbf{X}})^j}{\partial Y^i} \right|_{\hat{\mathbf{y}}=\hat{\mathbf{x}}} + (\mathbf{F}_p^{-1})^j_n \mathcal{P}^n_{mi} \hat{b}^m \right\} \hat{\mathbf{g}}_j \\ &= \left\{ \left. \frac{\partial (\hat{\mathbf{b}}_{\mathbf{X}})^j}{\partial Y^i} \right|_{\hat{\mathbf{y}}=\hat{\mathbf{x}}} + (\mathbf{F}_p^{-1})^j_n \mathcal{P}^n_{mi} (A^{-1})^m_k b^k \right\} \hat{\mathbf{g}}_j \\ &= \left\{ \left. \frac{\partial (\hat{\mathbf{b}}_{\mathbf{X}})^j}{\partial Y^i} \right|_{\hat{\mathbf{y}}=\hat{\mathbf{x}}} + (A^{-1})^j_r (\mathbf{f}_p^{-1})^r_n \mathcal{P}^n_{mi} (A^{-1})^m_k b^k \right\} \hat{\mathbf{g}}_j \\ &= \left. \frac{\partial (\hat{\mathbf{b}}_{\mathbf{X}})^j}{\partial Y^i} \right|_{\hat{\mathbf{y}}=\hat{\mathbf{x}}} \hat{\mathbf{g}}_j + (\mathbf{f}_p^{-1})^r_n \mathcal{P}^n_{mi} (A^{-1})^m_k b^k \hat{\rho}_r \quad . \end{aligned} \quad (10.108)$$

On the other hand, by virtue of (10.90), (10.91),

$$\frac{\partial \hat{\mathbf{b}}}{\partial X^i} = \left(\frac{\partial b^j}{\partial X^i} + (\mathbf{f}_p^{-1})^j_n \frac{\partial (\mathbf{f}_p^n)_m}{\partial X^i} b^m \right) \hat{\rho}_j \quad . \quad (10.109)$$

On requiring again the equalities (10.103), (10.104), we conclude, with the aid of the last two equations, that

$$\left. \frac{\partial (\hat{\mathbf{b}}_{\mathbf{X}})^j}{\partial Y^i} \right|_{\hat{\mathbf{y}}=\hat{\mathbf{x}}} \hat{\mathbf{g}}_j = \frac{\partial b^j}{\partial X^i} \hat{\rho}_j + (\mathbf{f}_p^{-1})^j_n \left(\frac{\partial (\mathbf{f}_p^n)_m}{\partial X^i} - \mathcal{P}^n_{ki} (A^{-1})^k_m \right) b^m \hat{\rho}_j \quad . \quad (10.110)$$

If now an arbitrary covariant derivative on $\hat{\mathcal{M}}(\hat{\mathbf{x}}, t)$ were defined by

$$\hat{\nabla}\hat{\mathbf{b}}_{\mathbf{X}} := \left\{ \frac{\partial (\hat{\mathbf{b}}_{\mathbf{X}})^j}{\partial Y^i} + \bar{\Lambda}^j_{im} (\hat{\mathbf{b}}_{\mathbf{X}})^m \right\} (\hat{\nu}_{\mathbf{X}})_j \otimes (\hat{\nu}_{\mathbf{X}})^i \quad , \quad (10.111)$$

with

$$\bar{\Lambda}_{im}^j = \bar{\Lambda}_{im}^j(\hat{\mathbf{x}}, \hat{\mathbf{y}}, t) \quad , \quad (10.112)$$

so that, at $\hat{\mathbf{y}} = \hat{\mathbf{x}}$,

$$\begin{aligned} \hat{\nabla} \hat{\mathbf{b}}_{\mathbf{X}}|_{\hat{\mathbf{y}}=\hat{\mathbf{x}}} &= \left. \frac{\partial (\hat{\mathbf{b}}_{\mathbf{X}})^j}{\partial Y^i} \right|_{\hat{\mathbf{y}}=\hat{\mathbf{x}}} \hat{\mathbf{g}}_j \otimes \hat{\mathbf{g}}^i + \bar{\Lambda}_{im}^j|_{\hat{\mathbf{y}}=\hat{\mathbf{x}}} \hat{b}^m \hat{\mathbf{g}}_j \otimes \hat{\mathbf{g}}^i \\ &= \frac{\partial b^j}{\partial X^i} \hat{\rho}_j \otimes \hat{\mathbf{g}}^i + (\mathbf{f}_p^{-1})^j_n \left(\frac{\partial (\mathbf{f}_p)_m^n}{\partial X^i} - \mathcal{P}_{ki}^n (A^{-1})^k_m \right) b^m \hat{\rho}_j \otimes \hat{\mathbf{g}}^i \\ &\quad + \bar{\Lambda}_{im}^j|_{\hat{\mathbf{y}}=\hat{\mathbf{x}}} (A^{-1})^m_k b^k A^r_j \hat{\rho}_r \otimes \hat{\mathbf{g}}^i \quad , \end{aligned} \quad (10.113)$$

or

$$\hat{\nabla} \hat{\mathbf{b}}_{\mathbf{X}}|_{\hat{\mathbf{y}}=\hat{\mathbf{x}}} = \left(\frac{\partial b^j}{\partial X^i} + \left\{ (\mathbf{f}_p^{-1})^j_n \left(\frac{\partial (\mathbf{f}_p)_m^n}{\partial X^i} - \mathcal{P}_{ki}^n (A^{-1})^k_m \right) + A^j_r \bar{\Lambda}_{ik}^r|_{\hat{\mathbf{y}}=\hat{\mathbf{x}}} (A^{-1})^k_m \right\} b^m \right) \hat{\rho}_j \otimes \hat{\mathbf{g}}^i \quad , \quad (10.114)$$

then, the result (10.107) were be reestablished,

$$\hat{\nabla} \hat{\mathbf{b}}_{\mathbf{X}}|_{\hat{\mathbf{y}}=\hat{\mathbf{x}}} = \hat{\nabla} \hat{\mathbf{b}} \quad , \quad (10.115)$$

provided Λ_{im}^j is given by

$$\Lambda_{im}^j = (\mathbf{f}_p^{-1})^j_n \left(\frac{\partial (\mathbf{f}_p)_m^n}{\partial X^i} - \mathcal{P}_{ki}^n (A^{-1})^k_m \right) + A^j_r \bar{\Lambda}_{ik}^r|_{\hat{\mathbf{y}}=\hat{\mathbf{x}}} (A^{-1})^k_m \quad . \quad (10.116)$$

This shows the relation of $\hat{\nabla} \hat{\mathbf{b}}$ to a covariant derivative, which is associated to local deformation.

10.6 Elastic and plastic parts of the micromorphic curvature tensor

We turn to the scalar differences in Eqs. (10.82), (10.83), and chose the differential operator $\nabla_{\hat{R}_t}$ to be given by $\hat{\nabla}$ (cf. Eq. (10.107)), so that

$$\nabla_{\hat{R}_t} \hat{\varphi}_2 = \left(\frac{\partial (\hat{\varphi}_2)^j}{\partial X^i} + \Lambda_{im}^j (\hat{\varphi}_2)^m \right) \hat{\rho}_j \otimes \hat{\mathbf{g}}^i \quad , \quad (10.117)$$

where

$$\hat{\varphi}_2 = (\hat{\varphi}_2)^j \hat{\rho}_j \quad , \quad \Phi_2 = (\Phi_2)^j \mathbf{E}_j \quad , \quad (\Phi_2)^j \equiv (\varphi_2)^j \quad . \quad (10.118)$$

It is readily seen that

$$\hat{\varphi}^1 \cdot (\nabla_{\hat{R}_t} \hat{\varphi}_2) [\hat{\mathbf{g}}_3] = \Phi^1 \cdot \mathbf{f}_p^{-1} (\nabla_{\hat{R}_t} \hat{\varphi}_2) \mathbf{F}_p [\mathbf{E}_3] = \Phi^1 \cdot \left\{ \left(\frac{\partial (\Phi_2)^j}{\partial X^i} + \Lambda_{im}^j (\Phi_2)^m \right) \mathbf{E}_j \otimes \mathbf{E}^i \right\} [\mathbf{E}_3] \quad . \quad (10.119)$$

Also, from (10.40),

$$\nabla_{\mathcal{R}_R} \Phi_2 = \left(\frac{\partial (\Phi_2)^j}{\partial X^i} + \lambda_{im}^j (\Phi_2)^m \right) \mathbf{E}_j \otimes \mathbf{E}^i \quad , \quad (10.120)$$

with $\lambda_{im}^j \equiv \lambda_{jim} = 0$ being the symbols, relative to $\{\mathbf{E}_i\}$, of the Levi-Civita connection in \mathcal{R}_R (see Sect. 10.8). Thus, after inserting into (10.83),

$$(\Delta_c)_p = \Phi^1 \cdot \{(\Lambda_{im}^j - \lambda_{im}^j)(\Phi_2 \cdot \mathbf{E}^m)\}(\mathbf{E}_j \otimes \mathbf{E}^i)[\mathbf{E}_3] \quad , \quad (10.121)$$

or

$$(\Delta_c)_p = \tilde{\mathcal{K}}_p[\Phi^1, \Phi_2, \mathbf{E}_3] \quad , \quad (10.122)$$

with

$$\tilde{\mathcal{K}}_p = (\tilde{\mathcal{K}}_p)^j_{mi} \mathbf{E}_j \otimes \mathbf{E}^m \otimes \mathbf{E}^i \quad , \quad (10.123)$$

$$(\tilde{\mathcal{K}}_p)^j_{mi} \equiv (\tilde{\mathcal{K}}_p)_{jmi} = \Lambda_{im}^j - \lambda_{im}^j \quad . \quad (10.124)$$

In addition, it can be seen that

$$(\Delta_c)_e = \tilde{\mathcal{K}}_e[\Phi^1, \Phi_2, \mathbf{E}_3] \quad (10.125)$$

with

$$\tilde{\mathcal{K}} = \tilde{\mathcal{K}}_e + \tilde{\mathcal{K}}_p \quad . \quad (10.126)$$

On requiring from the differences Δ_c , $(\Delta_c)_e$, and $(\Delta_c)_p$ to be form-invariant with respect to the chosen configuration, it is straightforward to deduce, after some algebraic manipulations, that, e.g., relative to the plastic intermediate configuration, the relations

$$\Delta_c = \hat{\mathcal{K}}[\hat{\varphi}^1, \hat{\varphi}_2, \hat{\mathbf{g}}_3] \quad , \quad \hat{\mathcal{K}} = \mathcal{L}(\mathbf{f}_p, \mathbf{f}_p^{T-1}, \mathbf{F}_p^{T-1})[\tilde{\mathcal{K}}] \quad , \quad (10.127)$$

$$(\Delta_c)_e = \hat{\mathcal{K}}_e[\hat{\varphi}^1, \hat{\varphi}_2, \hat{\mathbf{g}}_3] \quad , \quad \hat{\mathcal{K}}_e = \mathcal{L}(\mathbf{f}_p, \mathbf{f}_p^{T-1}, \mathbf{F}_p^{T-1})[\tilde{\mathcal{K}}_e] \quad , \quad (10.128)$$

$$(\Delta_c)_p = \hat{\mathcal{K}}_p[\hat{\varphi}^1, \hat{\varphi}_2, \hat{\mathbf{g}}_3] \quad , \quad \hat{\mathcal{K}}_p = \mathcal{L}(\mathbf{f}_p, \mathbf{f}_p^{T-1}, \mathbf{F}_p^{T-1})[\tilde{\mathcal{K}}_p] \quad , \quad (10.129)$$

$$\hat{\mathcal{K}} = \hat{\mathcal{K}}_e + \hat{\mathcal{K}}_p \quad (10.130)$$

apply. This proves that the additive decomposition of Δ_c yields additive decompositions of the micromorphic curvature tensors $\tilde{\mathcal{K}}$, $\hat{\mathcal{K}}$, \mathcal{K} , and so forth. Obviously, tensors $\tilde{\mathcal{K}}$, $\hat{\mathcal{K}}$, \mathcal{K} , ... are members of an equivalence class. Postulating also $(\Delta_c)'$, $(\Delta_c)'_e$, $(\Delta_c)'_p$, ... to be form-invariant with respect to the chosen configuration, associated rates for the micromorphic curvature tensors and their elastic and plastic parts can be defined in a natural way, as it is shown in Grammenoudis and Tsakmakis [73, 74].

10.7 Concluding remarks

A family of micromorphic curvature tensors $\tilde{\mathcal{K}}$, $\hat{\mathcal{K}}$, \mathcal{K} has been introduced by representing the scalar valued difference Δ_c form-invariantly with respect to the chosen configuration. Multiplicative decompositions of \mathbf{F} and \mathbf{f} into elastic and plastic parts, together with the introduction of a relative covariant derivative on \hat{R}_t , allow to decompose Δ_c also into elastic and plastic parts. Latter may be represented form-invariantly by employing elastic and plastic micromorphic curvature tensors. In particular, the plastic part of the micromorphic curvature tensor relative to \mathcal{R}_R is denoted by $\tilde{\mathcal{K}}_p$ and posses components relative to Cartesian bases, which are given by connection differences, $(\tilde{\mathcal{K}}_p)^j_{mi} = \Lambda_{im}^j - \lambda_{im}^j$.

This outlines the tensorial character of $(\tilde{\mathcal{K}}_p)^j_{mi}$. (Symbols of connections are not components of third-order tensors, but symbols of connection differences are.) Further families of micromorphic curvature tensors are offered by appealing other scalar differences.

Fundamental properties of any plasticity theory are reflected by the geometrical structure it assigns to the space $\mathcal{R}_{\mathcal{R}}$. Important issues of the geometrical structure are the metric coefficients and the symbols of connection. Former, not discussed here, are related to strain tensors. The symbols of connection are practically determined from $\tilde{\mathcal{K}}_p$, which has to be determined from appropriate constitutive laws. There are two possibilities for such constitutive laws.

1. Λ^j_{im} , and therefore $\tilde{\mathcal{K}}_p$ too, are not subject to some compatibility conditions, so that the Riemannian curvature tensor is non-vanishing. Then separate constitutive laws are needed for plastic strain variables and for $\tilde{\mathcal{K}}_p$.
2. Λ^j_{im} in Eq. (10.124) is assumed to be equal to $(\Lambda_{\mathbf{f}_p})^j_{im}$ in Eq. (10.91). Since the right hand side of (10.91) is related to the gradient of \mathbf{f}_p , it is not necessary to postulate constitutive relations governing the response of $\tilde{\mathcal{K}}_p$, provided some evolution equations for \mathbf{f}_p are available.

Appendix

10.8 Manifold with connection

The relations given in this Section may be consulted, e.g., in the textbooks [141, 124, 142, 117, 59].

Let \mathbf{u} , \mathbf{v} be two vector fields on a manifold with affine connection, and let Λ^i_{jk} be the Christoffel symbols of the connection with respect to the arbitrary basis $\{\mathbf{g}_i\}$. The torsion of the connection is a third-order tensor \mathcal{T} , defined by

$$\mathcal{T}[\cdot, \mathbf{u}, \mathbf{v}] := \nabla_{\mathbf{u}}\mathbf{v} - \nabla_{\mathbf{v}}\mathbf{u} - [\mathbf{u}, \mathbf{v}] \quad , \quad (10.131)$$

where $[\mathbf{u}, \mathbf{v}]$ is the Lie bracket of \mathbf{u} , \mathbf{v} and $\nabla_{\mathbf{v}}\mathbf{u}$ is the covariant derivative of \mathbf{u} along \mathbf{v} . With respect to $\{\mathbf{g}_i\}$, the components of \mathcal{T} read

$$\mathcal{T}^i_{jk} = (\Lambda^i_{jk} - \Lambda^i_{kj}) - \mathcal{C}^i_{jk} \quad , \quad (10.132)$$

with \mathcal{C}^i_{jk} being the objects of anholonomy for the chosen basis $\{\mathbf{g}_i\}$. The connection is called torsion-free or symmetric, if \mathcal{T} is vanishing, while the objects of connection Λ^i_{jk} are called symmetric if $\Lambda^i_{jk} = \Lambda^i_{kj}$. Two cases are of particular interest.

- a) The chosen basis is holonomic, so that $\mathcal{C}^i_{jk} = 0$ and $\mathcal{T}^i_{jk} = \Lambda^i_{jk} - \Lambda^i_{kj}$. In this case the connection is symmetric if and only if its objects Λ^i_{jk} are symmetric.
- b) The chosen basis is anholonomic, so that $\mathcal{C}^i_{jk} \neq 0$. Then, the connection is symmetric if and only if $\Lambda^i_{jk} - \Lambda^i_{kj} = \mathcal{C}^i_{jk}$. That means, the objects Λ^i_{jk} are not symmetric. If $\mathcal{T}^i_{jk} \neq 0$, then Λ^i_{jk} may be symmetric or not.

Generally, the connection may be characterized by the formula

$$\Lambda^r_{jl} = \frac{1}{2}g^{rk}(\partial_l g_{ik} + \partial_i g_{kl} - \partial_k g_{li}) + \frac{1}{2}(\mathcal{T}^r_{il} + \mathcal{T}^r_{li} - \mathcal{T}^r_{il}) + \frac{1}{2}(\mathcal{C}^r_{il} + \mathcal{C}^r_{li} - \mathcal{C}^r_{il}) + \frac{1}{2}(\mathcal{Q}^r_{li} + \mathcal{Q}^r_{il} - \mathcal{Q}^r_{li}) \quad , \quad (10.133)$$

where quantities g_{ij} and g^{ij} are used to raise and lower indices, and $\partial_i(\cdot)$ denotes the derivative of (\cdot) along the basis vector \mathbf{g}_i . If $\{\mathbf{g}_i\}$ is holonomic, then $\partial_i(\cdot)$ reduces to the common partial derivative operator. Objects Q_{lik} describe the compatibility of the connection with the metric, i.e., Q_{lik} measures the lack of vanishing of the covariant derivative of the metric,

$$-Q_{lik} \equiv -Q_{lki} := \partial_l g_{ik} - \Lambda^m_{li} g_{mk} - \Lambda^m_{lk} g_{im} \quad . \quad (10.134)$$

Three cases can be distinguished.

- a) The connection is symmetric (torsion-free). Then the expression in brackets enclosing the torsion terms is vanishing.
- b) The chosen basis is holonomic. Then the expression in brackets enclosing objects of anholonomy is vanishing.
- c) The connection is metric with respect to g_{ik} . Then the expression in the last brackets on the righthand side of (10.133) is vanishing.

On manifolds endowed with a metric, the following "fundamental theorem of Riemannian Geometry" holds. There exists a unique, so-called Levi Civita connection, which is symmetric (torsion-free) and metric, i.e., parallel translation preserves inner products. We shall use the letter λ to denote the Levi Civita connection.

Aside from the metric and the connection, the manifold may be characterized by the Riemann (or Riemann-Christoffel) curvature tensor \mathcal{R} of the connection, which is a fourth-order tensor. With respect to the arbitrary basis $\{\mathbf{g}_i\}$, the components of \mathcal{R} are

$$\mathcal{R}^r_{ijm} = \partial_j \Lambda^r_{mi} - \partial_m \Lambda^r_{ji} + \Lambda^r_{jn} \Lambda^n_{mi} - \Lambda^r_{mn} \Lambda^n_{ji} + C^n_{mj} \Lambda^r_{ni} \quad . \quad (10.135)$$

An Euclidean manifold is endowed with both an Euclidean metric and a Levi-Civita connection, the objects of which vanish with respect to Cartesian coordinate systems. Hence, the Riemann curvature tensor vanishes too. The reversed statement asserts that every manifold endowed with a symmetric, metric connection, and vanishing Riemann curvature tensor, is an Euclidean one.

In manifolds with vanishing Riemann curvature tensor, parallel translation of vectors of a point P to a point Q is path independent. Such manifolds are said to be flat, or to possess teleparallelism. The manifold is said to be Riemannian, if it is endowed with a Riemannian metric, a symmetric, metric connection, and a non-vanishing Riemann curvature tensor. One says also that the manifold is curved. In plasticity theories it can happen, that the manifold is structured with non-Euclidean metric, and a non-metric and non-symmetric connection. The Riemann curvature tensor may vanish or not. Such manifolds are generally called as non-Riemannian and non-Euclidean.

11 Micromorphic continuum. Part I: Strain and stress tensors and their associated rates

P. Grammenoudis, Ch. Tsakmakis

International Journal of Non-Linear Mechanics, 44 (2009), 943–956

Micromorphic continuum.
Part I: Strain and stress tensors and their associated rates

P. Grammenoudis, Ch. Tsakmakis

**Darmstadt University of Technology, Institute of Continuum Mechanics,
Hochschulstraße 1, 64289 Darmstadt, Germany**

Abstract

Micropolar and micromorphic solids are continuum mechanics models, which take into account, in some sense, the microstructure of the considered real material. The characteristic property of such continua is that the state functions depend, besides the classical deformation of the macroscopic material body, also upon the deformation of the microcontinuum modeling the microstructure, and its gradient with respect to the space occupied by the material body. While micropolar plasticity theories, including non-linear isotropic and non-linear kinematic hardening, have been formulated, even for non-linear geometry, few works are known yet about the formulation of (finite deformation) micromorphic plasticity. It is the aim of the three papers (Parts I, II and III) to demonstrate how micromorphic plasticity theories may be formulated in a thermodynamically consistent way.

In the present article we start by outlining the framework of the theory. Especially, we confine attention to the theory of Mindlin on continua with microstructure, which is formulated for small deformations. After precisising some conceptual aspects concerning the notion of microcontinuum, we work out a finite deformation version of theory, suitable for our aims. It is examined that resulting basic field equations are the same as in the non-linear theory of Eringen, which deals with a different definition of the microcontinuum. Furthermore, geometrical interpretations of strain and curvature tensors are elaborated. This allows to find out associated rates in a natural manner. Dual stress and double stress tensors, as well as associated rates, are then defined on the basis of the stress powers. This way, it is possible to relate strain tensors (respectively, micromorphic curvature tensors) and stress tensors (respectively, double stress tensors), as well as associated rates, independently of the particular constitutive properties.

11.1 Introduction

It is well recognized that non-locality effects have to be involved in a plasticity theory when discussing localization phenomena or size effects in the material response. One possibility to augment classical theories to capture non-locality aspects is to incorporate higher order gradients of the kinematical and dynamical variables (e.g. [3, 5, 51, 52, 154, 123, 122, 49, 45, 46, 149, 150, 54, 53, 10, 12, 38, 118, 34, 33, 67, 69, 70]).

Among the continuum theories involving higher order of gradients there are some continuum mo-

dels which take into account, in some sense, the microstructure of the real material (continua with microstructure), as, e.g. the micropolar and the micromorphic ones. The formulation of micropolar plasticity is progressed as can be recognized, e.g. from the works [53, 10, 11, 149, 138, 67, 69], and the references cited there. On the other hand, some interesting ideas concerning finite deformation micromorphic plasticity have been elaborated in Forest and Sievert [55, 56], Sansour [139], and Hirschberger and Steinmann [87]. In particular the comprehensive work of Forest and Sievert [55], provides a unified thermomechanical framework for the development of micromorphic plasticity. Nevertheless, several aspects of (finite deformation) micromorphic plasticity are not broadly investigated, concerning among others geometrical issues of deformation decompositions into elastic and plastic parts, or formulation of hardening laws like kinematic hardening rules. Thus, the aim of the first two works (Part I and Part II) is to sketch how (finite deformation) micromorphic plasticity models may be formulated in a thermodynamically consistent way, while Part III is concerned with the discussion of examples which are calculated numerically. In the first article, we shall present the framework of our micromorphic theory, and the variables which are chosen as appropriate for formulating the constitutive laws.

Eringen and Suhubi (see, e.g. [49]) introduced and discussed micromorphic theories, which capture the microstructure of the real material by assuming a microvolume to be included in each material particle of the macroscopic body ("macroelements are constructed by microelements"). On the other hand, Mindlin proposed an elasticity theory, in which also the microstructure of the real material is modeled by embedding a microvolume in each particle of the macromaterial. Mindlin's theory differs from that one according to Eringen in that both the macro- and the micromaterial contribute to the kinetic energy-density of the overall material. The seminal works of Eringen and Mindlin are today the basis for every micromorphic continuum theory, and provide relevant field equations. Now, for a clear formulation of the basic concepts, it is perhaps helpful to address the question how small or how large can be the microvolume. If the microvolume is finite, what happens with material points in the neighborhood of the boundary of the continuum. Is there allowed for a part of the microvolume to be not included in the macrovolume element or even in the range of the continuum? In attempting to clarify such questions the authors were leaded to postulate the concept of microstructure something other than in the aforementioned works. But otherwise, as we shall see, not new basic equations may be gained by using this method.

In the present article, we adopt the proposal of Mindlin for establishing the balance laws of momentum and moment of momentum, in a fashion which allows the microcontinuum to exhibit arbitrary finite dimensions. In our opinion this can be a convenient way, when modeling microphysical properties in the framework of phenomenological continuum mechanics. It is examined that basic field equations established for non-linear geometry by Eringen's theory, may be recovered by the version of Mindlin's theory as accommodated here. Moreover, we elaborate geometrical interpretations for the strain and curvature tensors, which enter in the constitutive theory to be presented in Part II. This allows to find out associated rates in a natural manner. The method we pursue here is similar to the one developed by Haupt and Tsakmakis [82] in the context of classical continuum mechanics. Dual stress and double stress tensors, as well as associated rates, are then introduced on the basis of the stress powers. Thus, we relate strain (respectively, micromorphic curvature) and stress (respectively, double stress) tensors with each other, as well as associated rates, independently of the particular constitutive properties. It is shown that our approach is a generalization of the known method of conjugate variables in classical continuum mechanics. In fact, we extend the method of conjugate variables, on the one hand by covering also spacial variables, and on the other hand by dealing with double stress tensors.

11.2 Preliminaries

We consider isothermal deformations and write \mathbb{R} for the axis of real numbers, and $\dot{\varphi}(t)$ for the material time derivative of a function $\varphi(t)$, where t is the time. An explicit reference to space will be dropped in most part of the paper. Commonly, the same symbol is used to designate a function and the value of that function at a point. However, if we deal with different representations of the same function, then use will often be made of different symbols. For real x , $\langle x \rangle$ denotes the function

$$\langle x \rangle := \begin{cases} x & \text{if } x \geq 0 \\ 0 & \text{if } x < 0 \end{cases} . \quad (11.1)$$

Second-order tensors, like vectors, are denoted by bold-face Latin or Greek letters. In particular, $\mathbf{a} \cdot \mathbf{b}$ and $\mathbf{a} \otimes \mathbf{b}$ denote the inner product and the tensor product of the vectors \mathbf{a} and \mathbf{b} , respectively. For second-order tensors \mathbf{A} and \mathbf{B} , we write $\text{tr}\mathbf{A}$, $\det \mathbf{A}$ and \mathbf{A}^T for the trace, the determinant and the transpose of \mathbf{A} , respectively, while $\mathbf{A} \cdot \mathbf{B} = \text{tr}(\mathbf{A}\mathbf{B}^T)$ is the inner product between \mathbf{A} and \mathbf{B} , and $\|\mathbf{A}\| = \sqrt{\mathbf{A} \cdot \mathbf{A}}$ is the Euclidean norm of \mathbf{A} . Furthermore,

$$\mathbf{1} = \delta_{ij} \bar{\mathbf{e}}_i \otimes \bar{\mathbf{e}}_j \quad , \quad i, j = 1, 2, 3 \quad (11.2)$$

represents the identity tensor of second-order, where $\delta_{ij} = \delta_j^i = \delta_i^j$ is the Kronecker delta and $\{\bar{\mathbf{e}}_i\}$ is an orthonormal basis in the three-dimensional Euclidean vector space we deal with. Also, we use the notations $\mathbf{A}^D = \mathbf{A} - \frac{1}{3}(\text{tr}\mathbf{A})\mathbf{1}$ for the deviator of \mathbf{A} and $\mathbf{A}^{T-1} = (\mathbf{A}^{-1})^T$, provided \mathbf{A}^{-1} exists.

Third- and fourth-order tensors are denoted by bold-face calligraphic and double-stroke letters, respectively. Let \mathbf{A}, \mathbf{B} be fourth-order tensors, \mathcal{A}, \mathcal{B} third-order tensors, $\mathbf{A}, \mathbf{B}, \mathbf{C}, \mathbf{D}, \mathbf{E}, \mathbf{F}$ second-order tensors and $\mathbf{a}, \mathbf{b}, \mathbf{c}, \mathbf{d}$ vectors. With respect to the orthonormal basis $\{\bar{\mathbf{e}}_i\}$, the components of $\mathbf{A}, \mathbf{B}, \mathcal{A}, \mathcal{B}, \mathbf{A}, \mathbf{B}, \mathbf{C}, \mathbf{D}, \mathbf{E}, \mathbf{F}, \mathbf{a}, \mathbf{b}, \mathbf{c}, \mathbf{d}$ are $\mathbb{A}_{ijkl}, \mathbb{B}_{ijkl}, \mathcal{A}_{ijk}, \mathcal{B}_{ijk}, A_{ij}, B_{ij}, C_{ij}, D_{ij}, E_{ij}, F_{ij}, a_i, b_i, c_i, d_i$ (often use will be made of notations of the form $A_{ij} = (\mathbf{A})_{ij}$). Then, we have

$$\mathbf{A}\mathbf{B} = \mathbb{A}_{ijmn} \mathbb{B}_{mnkl} \bar{\mathbf{e}}_i \otimes \bar{\mathbf{e}}_j \otimes \bar{\mathbf{e}}_k \otimes \bar{\mathbf{e}}_l \quad , \quad (11.3)$$

$$\mathbf{A}^T = \mathbb{A}_{klij} \bar{\mathbf{e}}_i \otimes \bar{\mathbf{e}}_j \otimes \bar{\mathbf{e}}_k \otimes \bar{\mathbf{e}}_l \quad , \quad (11.4)$$

$$\mathbf{A}[\mathbf{B}] = \mathbb{A}_{ijmn} B_{mn} \bar{\mathbf{e}}_i \otimes \bar{\mathbf{e}}_j \quad , \quad (11.5)$$

$$\mathbf{B} \cdot \mathbf{A}[\mathbf{C}] = \mathbf{A}^T[\mathbf{B}] \cdot \mathbf{C} \quad , \quad (11.6)$$

$$\mathbf{A}^2 = \mathbf{A}\mathbf{A} = A_{ij} A_{jk} \bar{\mathbf{e}}_i \otimes \bar{\mathbf{e}}_k \quad , \quad (\mathbf{A}^{-2} = \mathbf{A}^{-1} \mathbf{A}^{-1}) \quad , \quad (11.7)$$

$$\mathbf{A}\mathbf{a} \equiv \mathbf{A}[\mathbf{a}] = A_{ij} a_j \bar{\mathbf{e}}_i \quad , \quad (11.8)$$

$$\mathbf{A}\mathbf{B} = B_{ij} (\mathbf{A}\bar{\mathbf{e}}_i) \otimes \bar{\mathbf{e}}_j = A_{ij} \bar{\mathbf{e}}_i \otimes (\mathbf{B}^T \bar{\mathbf{e}}_j) \quad , \quad (11.9)$$

$$\mathbf{A}[\mathbf{a}, \mathbf{b}] = A_{ij} (\mathbf{a} \cdot \bar{\mathbf{e}}_i) (\mathbf{b} \cdot \bar{\mathbf{e}}_j) = \mathbf{a} \cdot \mathbf{A}\mathbf{b} = A_{ij} a_i b_j \quad , \quad (11.10)$$

$$\mathcal{A}[\mathbf{a}, \mathbf{b}, \mathbf{c}] = \mathcal{A}_{ijk} (\mathbf{a} \cdot \bar{\mathbf{e}}_i) (\mathbf{b} \cdot \bar{\mathbf{e}}_j) (\mathbf{c} \cdot \bar{\mathbf{e}}_k) = \mathcal{A}_{ijk} a_i b_j c_k \quad , \quad (11.11)$$

$$\mathcal{A}[\mathbf{a}] = \mathcal{A}_{ijk} \bar{\mathbf{e}}_i \otimes \bar{\mathbf{e}}_j (\mathbf{a} \cdot \bar{\mathbf{e}}_k) = \mathcal{A}_{ijk} a_k \bar{\mathbf{e}}_i \otimes \bar{\mathbf{e}}_j \quad , \quad (11.12)$$

$$(\mathbf{A} \otimes \mathbf{d})[\mathbf{a}, \mathbf{b}, \mathbf{c}] = (\mathbf{a} \cdot \mathbf{A}\mathbf{b})(\mathbf{d} \cdot \mathbf{c}) \quad , \quad (11.13)$$

$$\mathcal{A} \cdot \mathcal{B} = \mathcal{A}_{ijk} \mathcal{B}_{lmn} (\bar{\mathbf{e}}_i \cdot \bar{\mathbf{e}}_l) (\bar{\mathbf{e}}_j \cdot \bar{\mathbf{e}}_m) (\bar{\mathbf{e}}_k \cdot \bar{\mathbf{e}}_n) = \mathcal{A}_{ijk} \mathcal{B}_{ijk} \quad , \quad (11.14)$$

$$\|\mathcal{A}\| = \sqrt{\mathcal{A} \cdot \mathcal{A}} \quad . \quad (11.15)$$

The products $\mathbf{A}\mathcal{A}, \mathcal{A}\mathbf{A}, \mathcal{A} \diamond \mathbf{A} \equiv \mathbf{A}^T \diamond \mathcal{A}$ are defined to represent third-order tensors given by

$$\mathbf{A}\mathcal{A} := \mathcal{A}_{ijk} (\mathbf{A}\bar{\mathbf{e}}_i) \otimes \bar{\mathbf{e}}_j \otimes \bar{\mathbf{e}}_k = A_{pi} \mathcal{A}_{ijk} \bar{\mathbf{e}}_p \otimes \bar{\mathbf{e}}_j \otimes \bar{\mathbf{e}}_k \quad , \quad (11.16)$$

$$\mathbf{A}\mathbf{A} := \mathcal{A}_{ijk}\bar{\mathbf{e}}_i \otimes \bar{\mathbf{e}}_j \otimes (\mathbf{A}^T\bar{\mathbf{e}}_k) = \mathcal{A}_{ijk}A_{kp}\bar{\mathbf{e}}_i \otimes \bar{\mathbf{e}}_j \otimes \bar{\mathbf{e}}_p \quad , \quad (11.17)$$

$$\mathbf{A} \diamond \mathbf{A} \equiv \mathbf{A}^T \diamond \mathbf{A} := \mathcal{A}_{ijk}\bar{\mathbf{e}}_i \otimes (\mathbf{A}^T\bar{\mathbf{e}}_j) \otimes \bar{\mathbf{e}}_k = \mathcal{A}_{ijk}A_{jp}\bar{\mathbf{e}}_i \otimes \bar{\mathbf{e}}_p \otimes \bar{\mathbf{e}}_k \quad , \quad (11.18)$$

while $\mathcal{A}[\mathbf{A}]$ represents the vector

$$\mathcal{A}[\mathbf{A}] = \mathcal{A}_{ijk}\{(\bar{\mathbf{e}}_j \otimes \bar{\mathbf{e}}_k) \cdot \mathbf{A}\}\bar{\mathbf{e}}_i = \mathcal{A}_{ijk}A_{jk}\bar{\mathbf{e}}_i \quad . \quad (11.19)$$

We introduce a linear operator $(\mathbf{A}, \mathbf{B}, \mathbf{C}) \mapsto \mathcal{L}(\mathbf{A}, \mathbf{B}, \mathbf{C})$, acting on the space of all third-order tensors, by

$$\mathcal{L}(\mathbf{A}, \mathbf{B}, \mathbf{C}) : \mathcal{A} \mapsto \mathcal{L}(\mathbf{A}, \mathbf{B}, \mathbf{C})[\mathcal{A}] = \mathcal{A}_{ijk}(\mathbf{A}\bar{\mathbf{e}}_i) \otimes (\mathbf{B}\bar{\mathbf{e}}_j) \otimes (\mathbf{C}\bar{\mathbf{e}}_k) \quad , \quad (11.20)$$

or, with respect to the orthonormal basis $\{\bar{\mathbf{e}}_i\}$,

$$(\mathcal{L}(\mathbf{A}, \mathbf{B}, \mathbf{C})[\mathcal{A}])_{mnp} = A_{mi}B_{nj}C_{pk}\mathcal{A}_{ijk} \quad . \quad (11.21)$$

It can be seen that

$$\mathcal{L}(\mathbf{A}\mathbf{B}, \mathbf{C}\mathbf{D}, \mathbf{E}\mathbf{F}) = \mathcal{L}(\mathbf{A}, \mathbf{C}, \mathbf{E})\mathcal{L}(\mathbf{B}, \mathbf{D}, \mathbf{F}) \quad , \quad (11.22)$$

$$\mathcal{A} \cdot \mathcal{L}(\mathbf{A}, \mathbf{B}, \mathbf{C})[\mathcal{B}] = \mathcal{L}^T(\mathbf{A}, \mathbf{B}, \mathbf{C})[\mathcal{A}] \cdot \mathcal{B} = \mathcal{L}(\mathbf{A}^T, \mathbf{B}^T, \mathbf{C}^T)[\mathcal{A}] \cdot \mathcal{B} \quad (11.23)$$

and

$$\mathcal{L}^{-1}(\mathbf{A}, \mathbf{B}, \mathbf{C}) = \mathcal{L}(\mathbf{A}^{-1}, \mathbf{B}^{-1}, \mathbf{C}^{-1}) \quad , \quad (11.24)$$

provided \mathbf{A}^{-1} , \mathbf{B}^{-1} and \mathbf{C}^{-1} exist. For the particular case where $\mathcal{A} = \mathbf{D} \otimes \mathbf{a}$, we have

$$\mathcal{L}(\mathbf{A}, \mathbf{B}, \mathbf{C})[\mathbf{D} \otimes \mathbf{a}] = \mathbf{A}\mathbf{D}\mathbf{B}^T \otimes (\mathbf{C}\mathbf{a}) \quad . \quad (11.25)$$

In this case, we have also

$$\mathcal{A}[\mathbf{b}, \mathbf{c}, \mathbf{d}] = (\mathbf{D} \otimes \mathbf{a})[\mathbf{b}, \mathbf{c}, \mathbf{d}] = \mathbf{D}[\mathbf{b}, \mathbf{c}](\mathbf{a} \cdot \mathbf{d}) = (\mathbf{b} \cdot \mathbf{D}\mathbf{c})(\mathbf{a} \cdot \mathbf{d}) \quad . \quad (11.26)$$

We write \mathbf{I} for the fourth-order identity tensor,

$$\mathbf{I} = \delta_{im}\delta_{jn} \bar{\mathbf{e}}_i \otimes \bar{\mathbf{e}}_j \otimes \bar{\mathbf{e}}_m \otimes \bar{\mathbf{e}}_n \quad , \quad (11.27)$$

which satisfies the property

$$\mathbf{I} = \mathbf{E} + \mathbf{J} \quad , \quad (11.28)$$

$$\mathbf{E} = \mathbb{E}_{imjn} \bar{\mathbf{e}}_i \otimes \bar{\mathbf{e}}_m \otimes \bar{\mathbf{e}}_j \otimes \bar{\mathbf{e}}_n = \frac{1}{2}(\delta_{ij}\delta_{mn} + \delta_{in}\delta_{mj}) \bar{\mathbf{e}}_i \otimes \bar{\mathbf{e}}_m \otimes \bar{\mathbf{e}}_j \otimes \bar{\mathbf{e}}_n \quad , \quad (11.29)$$

$$\mathbf{J} = \mathbb{J}_{imjn} \bar{\mathbf{e}}_i \otimes \bar{\mathbf{e}}_m \otimes \bar{\mathbf{e}}_j \otimes \bar{\mathbf{e}}_n = \frac{1}{2}(\delta_{ij}\delta_{mn} - \delta_{in}\delta_{mj}) \bar{\mathbf{e}}_i \otimes \bar{\mathbf{e}}_m \otimes \bar{\mathbf{e}}_j \otimes \bar{\mathbf{e}}_n \quad . \quad (11.30)$$

Hence, for the symmetric and the skew-symmetric (anti-symmetric) part of the second-order tensor \mathbf{A} , denoted, respectively, by \mathbf{A}_S and \mathbf{A}_A , we have

$$\mathbf{A}_S = \mathbf{E}[\mathbf{A}] \quad , \quad \mathbf{A}_A = \mathbf{J}[\mathbf{A}] \quad , \quad (11.31)$$

while

$$\mathbb{I}[\mathbf{A}] = \mathbf{A} \quad . \quad (11.32)$$

We write \mathbf{S} for the fourth-order tensor with the property

$$\mathbf{S}[\mathbf{A}] = \mathbf{A}^T \quad . \quad (11.33)$$

Thus, every isotropic fourth-order tensor \mathbf{A} possesses the representation

$$\mathbf{A} = \alpha_1 \mathbf{1} \otimes \mathbf{1} + \alpha_2 \mathbb{I} + \alpha_3 \mathbf{S} \quad , \quad (11.34)$$

where α_1 , α_2 and α_3 are scalars.

If \mathcal{M} is a manifold, then $T\mathcal{M}$ is the tangent bundle of \mathcal{M} ,

$$T\mathcal{M} := \bigcup_{p \in \mathcal{M}} T_p \mathcal{M} \quad , \quad (11.35)$$

where $T_p \mathcal{M}$ is the tangent space to \mathcal{M} at p .

11.3 Kinematic

11.3.1 Micromorphic continuum

Consider a material body \mathcal{B} (macroscopic continuum, or macrocontinuum, or macroscopic material, or overall material body), with elements \mathcal{X} , \mathcal{Y} , \dots , which may be mapped into a region of the three dimensional Euclidean space \mathcal{E} . With an origin O fixed in \mathcal{E} , every point $P \in \mathcal{E}$ may be identified by a position vector \mathbf{p} , which belongs to the tangent space to \mathcal{E} at O . As usually in classical continuum mechanics, we shall often set \mathbf{p} equal to point P , and we shall speak of the point $\mathbf{p} \in \mathcal{E}$.

Microphysically, real materials like metals indicate some kind of patterning with discrete distributed mass. This may be addressed, when formulating constitutive properties of a material point, by taking into account not only the material point itself, but rather an entire neighborhood of the point. We may realize this by attaching to each material point $\mathcal{X} \in \mathcal{B}$, a material body $\mathcal{B}'(\mathcal{X})$ (microcontinuum, or microstructure), which serves to model the microphysical (microstructural) properties of the overall material body. It is assumed, that the same body \mathcal{B}' , with elements \mathcal{X}' , \mathcal{Y}' , \dots , is attached at every \mathcal{X} . A configuration of the body \mathcal{B} and its microstructure \mathcal{B}' is a map

$$(k, k') : (\mathcal{B}, \mathcal{B}') \rightarrow \mathcal{E} \times \mathcal{E} \quad , \quad (11.36)$$

$$(\mathcal{X}, \mathcal{X}') \mapsto \begin{pmatrix} k = k(\mathcal{X}) \\ k' = k'(\mathcal{X}, \mathcal{X}') \end{pmatrix} \quad , \quad (11.37)$$

with $k(\mathcal{B})$, $k'(\mathcal{X}, \mathcal{B}')$ open and simply connected subsets of \mathcal{E} . $k(\mathcal{B})$ and $k'(\mathcal{X}, \mathcal{B}')$ are denoted as the ranges in \mathcal{E} occupied, respectively, under the configuration (k, k') . We shall also write $(k, k') \equiv (\mathbf{k}, \mathbf{k}')$, and we shall set $k(\mathcal{B}) \equiv \mathbf{k}(\mathcal{B})$, $k'(\mathcal{X}, \mathcal{B}') \equiv \mathbf{k}'(\mathcal{X}, \mathcal{B}')$, where $\mathbf{k}(\mathcal{X})$ is a position vector with respect to origin O and $\mathbf{k}'(\mathcal{X}, \mathcal{X}')$ is a position vector emanated from point $\mathbf{k}(\mathcal{X}) \in \mathcal{E}$ and leading to the point in space occupied by \mathcal{X}' .

A fixed chosen configuration (χ_R, χ'_R) is called reference configuration of $(\mathcal{B}, \mathcal{B}')$,

$$(\mathcal{X}, \mathcal{X}') \mapsto \begin{pmatrix} \mathbf{X} = \chi_R(\mathcal{X}) \\ \mathbf{X}' = \chi'_R(\mathcal{X}, \mathcal{X}') \end{pmatrix}, \quad (11.38)$$

while a motion of $(\mathcal{B}, \mathcal{B}')$ in $\mathcal{E} \times \mathcal{E}$ is an one parameter family of configurations (χ, χ') , parameterized with time $t \in I$ ($I \subset \mathbb{R}$, I : interval),

$$(\chi, \chi') : \mathcal{B} \times \mathcal{B}' \times I \rightarrow \mathcal{E} \times \mathcal{E}, \quad (11.39)$$

$$(\mathcal{X}, \mathcal{X}', t) \mapsto \begin{pmatrix} \mathbf{x} = \chi(\mathcal{X}, t) \\ \mathbf{x}' = \chi'(\mathcal{X}, \mathcal{X}', t) \end{pmatrix}. \quad (11.40)$$

It is supposed, that for fixed time t , the map (χ, χ') possesses an inverse, so that $\mathcal{X}, \mathcal{X}'$ may be expressed in terms of \mathbf{x}, \mathbf{x}' . If the motion of $(\mathcal{B}, \mathcal{B}')$ starts at time t_0 , then the configuration $(\chi(\cdot, t_0), \chi'(\cdot, \cdot, t_0))$ is called the initial configuration. Accordingly, the configuration $(\chi(\cdot, t), \chi'(\cdot, \cdot, t))$ is denoted as actual or current or Eulerian configuration. In this article, we assume the initial configuration at time t_0 to coincide with the reference configuration,

$$\mathbf{x} = \chi(\mathcal{X}, t_0) \equiv \chi_R(\mathcal{X}), \quad (11.41)$$

$$\mathbf{x}' = \chi'(\mathcal{X}, \mathcal{X}', t_0) \equiv \chi'_R(\mathcal{X}, \mathcal{X}'). \quad (11.42)$$

It is common to call configurations different than the reference configuration as spatial ones. Also, it is assumed that, for fixed t , all inverse functions exist, so that the motion can be expressed in terms of \mathbf{X}, \mathbf{X}' . If no confusion may arise, following common praxis, we shall use the same symbols for these functions as in Eq. (11.40),

$$(\mathbf{X}, \mathbf{X}', t) \mapsto \begin{pmatrix} \mathbf{x} = \chi(\mathbf{X}, t) \equiv \chi_t(\mathbf{X}) \\ \mathbf{x}' = \chi'(\mathbf{X}, \mathbf{X}', t) \equiv \chi'_t(\mathbf{X}, \mathbf{X}') \end{pmatrix}. \quad (11.43)$$

Also, we shall write

$$\mathbf{u} = \mathbf{u}(\mathbf{X}, t) = \mathbf{x} - \mathbf{X} \quad (11.44)$$

for the macroscopic displacement vector. Functions (χ, χ') in this equation, for fixed time t , are referred to as deformation from the reference to the actual configuration. We refer to the ranges in \mathcal{E} $R_R := \chi_R(\mathcal{B})$, $R_t := \chi_t(\mathcal{B})$, $R'_R(\mathbf{X}) := \chi'_R(\mathcal{X}, \mathcal{B}')$, $R'_t(\mathbf{x}) := \chi'_t(\mathcal{X}, \mathcal{B}')$.

The introduction of microcontinua into the theory goes back essentially to Mindlin [122] and Eringen [45]. Here, the microcontinuum is supposed to be, in some sense, mechanically (we are dealing with isothermal processes and uniform distributed temperature only) equivalent to some patterned material neighborhood around the considered point. The mass in the microcontinuum is assumed to be continuously distributed. Generally, the microcontinuum as adopted in the present article, is a fictitious (conceptual) one, which may have arbitrary finite dimensions (see Fig. 11.1), i.e. the region in \mathcal{E} occupied by the microcontinuum at a material point of the macroscopic material must not necessarily be subset of the region occupied by the macroscopic material itself (see also Grammenoudis and Tsakmakis [71]), where this kind of microcontinuum has been invoked in a micropolar plasticity theory). Following Eringen (see, e.g. [46]), we define a micromorphic material to be a material body with a microcontinuum at each point, which suffers only homogeneous deformations.

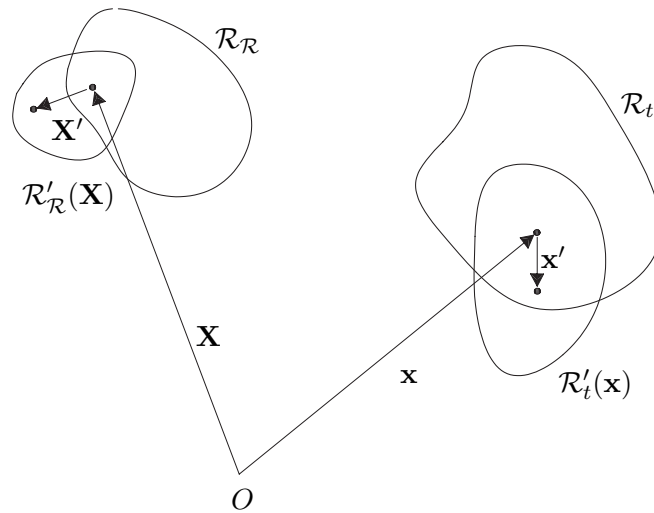

Figure 11.1: The region $\mathcal{R}'_{\mathcal{R}}(\mathbf{X})$ (respectively $\mathcal{R}'_t(\mathbf{x})$) must not necessarily be subset of the region $\mathcal{R}_{\mathcal{R}}$ (respectively \mathcal{R}_t).

11.3.2 Deformation

As for a classical continuum, the deformation of the macrocontinuum will be described by the (macro) deformation gradient tensor

$$\mathbf{F} = \mathbf{F}(\mathbf{X}, t) = \frac{\partial \boldsymbol{\chi}(\mathbf{X}, t)}{\partial \mathbf{X}} = \text{GRAD} \boldsymbol{\chi}(\mathbf{X}, t) \quad , \quad (11.45)$$

where $\det \mathbf{F} > 0$ is assumed. We distinguish between the operators GRAD and grad, representing the gradients with respect to \mathbf{X} and \mathbf{x} , respectively. Under arbitrary rigid body rotations \mathbf{Q} superposed on the actual configuration, \mathbf{F} transforms according to

$$\mathbf{F} \rightarrow \mathbf{F}^* = \mathbf{Q}\mathbf{F} \quad . \quad (11.46)$$

The right Cauchy-Green deformation tensor \mathbf{C} and the left Cauchy-Green deformation tensor \mathbf{B} are given by

$$\mathbf{C} = \mathbf{F}^T \mathbf{F} = \mathbf{U}^2 \quad , \quad \mathbf{B} = \mathbf{F}\mathbf{F}^T = \mathbf{V}^2 \quad , \quad (11.47)$$

in which \mathbf{U} and \mathbf{V} , called, respectively, the right and the left stretch tensors, are symmetric and positive definite. They appear in the polar decomposition of \mathbf{F} ,

$$\mathbf{F} = \mathbf{R}\mathbf{U} = \mathbf{V}\mathbf{R} \quad , \quad (11.48)$$

where \mathbf{R} is a proper orthogonal second-order tensor. The velocity gradient tensor is denoted by \mathbf{L} ,

$$\mathbf{L} := \text{grad} \dot{\boldsymbol{\chi}} = \dot{\mathbf{F}}\mathbf{F}^{-1} \quad , \quad (11.49)$$

with

$$\mathbf{L} = \mathbf{D} + \mathbf{W} \quad , \quad \mathbf{D} := \frac{1}{2}(\mathbf{L} + \mathbf{L}^T) \quad , \quad \mathbf{W} := \frac{1}{2}(\mathbf{L} - \mathbf{L}^T) \quad . \quad (11.50)$$

Similar to Eq. (11.45), the deformation of the microscopic body will be described by the microdeformation gradient tensor

$$\mathbf{f} = \mathbf{f}(\mathbf{X}, \mathbf{X}', t) := \frac{\partial \boldsymbol{\chi}'(\mathbf{X}, \mathbf{X}', t)}{\partial \mathbf{X}'} \quad , \quad (11.51)$$

with $\det \mathbf{f} > 0$ being assumed. As in the micromorphic continuum the microstructure suffers homogeneous deformations only, we have $\mathbf{f} = \mathbf{f}(\mathbf{X}, t)$. Geometrically, the macrodeformation gradient $\mathbf{F}(\mathbf{X}, t)$ is a two point tensor, i.e. it acts on a vector $\mathbf{A} \in T_{\mathbf{X}}\mathcal{R}_{\mathcal{R}}$ and furnishes a vector $\mathbf{a} = \mathbf{F}\mathbf{A} \in T_{\mathbf{x}}\mathcal{R}_t$. On the other hand, since \mathbf{f} is homogeneous deformation, \mathbf{f} may also be thought to be a two point tensor, which acts on vectors $\mathbf{A} \in T_{\mathbf{X}}\mathcal{R}_{\mathcal{R}}$ and furnishes vectors $\boldsymbol{\alpha} \in T_{\mathbf{x}}\mathcal{R}_t$. Assume \mathbf{A} , $\boldsymbol{\alpha}$ to be objective Lagrangean and objective Eulerian vectors respectively, i.e. under arbitrary rigid body rotations \mathbf{Q} superposed on the actual configuration (of the macroscopic body), \mathbf{A} , $\boldsymbol{\alpha}$ transforms according to $\mathbf{A}^* = \mathbf{A}$ and $\boldsymbol{\alpha}^* = \mathbf{Q}\boldsymbol{\alpha} = \mathbf{Q}\mathbf{f}\mathbf{A}$. Then, \mathbf{f} has to transform according to

$$\mathbf{f} \rightarrow \mathbf{f}^* = \mathbf{Q}\mathbf{f} \quad . \quad (11.52)$$

Keeping in mind $\det \mathbf{f} > 0$, the polar decomposition

$$\mathbf{f} = \mathbf{r}\mathbf{u} = \mathbf{v}\mathbf{r} \quad (11.53)$$

holds, with $\mathbf{r}, \mathbf{u}, \mathbf{v}$ being second-order tensors corresponding, respectively, to the tensors $\mathbf{R}, \mathbf{U}, \mathbf{V}$ in the polar decomposition (11.48). We use the symbol \mathbf{l} for the "microvelocity" gradient tensor,

$$\mathbf{l} := \dot{\mathbf{f}}\mathbf{f}^{-1} = \mathbf{d} + \mathbf{w} \quad , \quad (11.54)$$

$$\mathbf{d} := \frac{1}{2}(\mathbf{l} + \mathbf{l}^T) \quad , \quad \mathbf{w} := \frac{1}{2}(\mathbf{l} - \mathbf{l}^T) \quad . \quad (11.55)$$

(According to Eringen [46, p. 24], \mathbf{l} is called the microgyration tensor.)

If we set $\mathbf{x}' = \mathbf{f}(\mathbf{X}, t)\mathbf{X}'$ in Eq. (11.43), then the motion can be described by the map

$$(\mathbf{X}, \mathbf{X}', t) \mapsto \begin{pmatrix} \mathbf{x} = \boldsymbol{\chi}(\mathbf{X}, t) \\ \mathbf{x}' = \mathbf{f}(\mathbf{X}, t)\mathbf{X}' \end{pmatrix} \quad . \quad (11.56)$$

All what says this map can be reflected by considering instead of arbitrary vectors \mathbf{X}' , position vectors $\boldsymbol{\Phi}$ for the microcontinuum, which are arbitrary fields of \mathbf{X} , $\boldsymbol{\Phi} = \boldsymbol{\Phi}(\mathbf{X})$, and which are mapped to vectors $\boldsymbol{\varphi}(\mathbf{x}, t) = \mathbf{f}(\mathbf{X}, t)\boldsymbol{\Phi}(\mathbf{X})$. Then, for arbitrary but fixed $\boldsymbol{\Phi}(\cdot)$, Eq. (11.56) yields

$$(\mathbf{X}, t) \mapsto \begin{pmatrix} \mathbf{x} = \boldsymbol{\chi}(\mathbf{X}, t) \\ \boldsymbol{\varphi}(\mathbf{x}, t) = \mathbf{f}(\mathbf{X}, t)\boldsymbol{\Phi}(\mathbf{X}) \end{pmatrix} \quad . \quad (11.57)$$

11.3.3 Coordinate systems

As usually, the tangent space at any point of a manifold is defined to be an Euclidean vector space. The inner product in this space is denoted by a dot. Clearly, in the tangent space of every point there exists always an orthonormal basis, so that, with respect to this (perhaps local) basis, the components of the metric tensor will be given by the Kronecker delta symbol. If these bases form a field of coordinate basis vectors, tangent to a global coordinate system, then the metric coefficients of the metric on the manifold, will be given everywhere by the Kronecker delta symbol. In this case, the metric tensor on

the manifold is everywhere the identity tensor of the second order, and the manifold will be Euclidean. However, if it is not possible to select such a coordinate system, then the tangent vector spaces will still be Euclidean, but the metric of the manifold, and hence the manifold itself, will be not Euclidean. In this case, if we are given the metric coefficients at every point on the manifold, then there do not exist some coordinate transformations rendering the metric coefficients equal to the Kronecker delta everywhere. Nevertheless, the components of tensorial quantities will be expressed in terms of the Euclidean product, which holds always in the tangent space at every point.

It is assumed that $\mathcal{R}_{\mathcal{R}}$ and \mathcal{R}_t are Euclidean manifolds, and that they can be covered by coordinate lines of single coordinate systems, respectively. Let $\{X^i\}$, $\{x^i\}$ be Cartesian coordinate systems for $\mathcal{R}_{\mathcal{R}}$ and \mathcal{R}_t , inducing the coordinate bases $\mathbf{E}_i \equiv \mathbf{E}^i$, $\mathbf{e}_i \equiv \mathbf{e}^i$, respectively,

$$\mathbf{E}^i \cdot \mathbf{E}_j = \delta^i_j \quad , \quad \mathbf{e}^i \cdot \mathbf{e}_j = \delta^i_j \quad . \quad (11.58)$$

It is convenient to use the coordinate system $\{X^i\}$ as a convective one. Then the coordinate lines in $\mathcal{R}_{\mathcal{R}}$ of the coordinate system $\{X^i\}$ will represent material lines, which will be deformed in \mathcal{R}_t , to form the coordinate lines of the convective coordinate system. To a material point, it will be assigned in $\mathcal{R}_{\mathcal{R}}$ and \mathcal{R}_t the same values of convective coordinates $\{X^i\}$, but the corresponding local coordinate basis will be different. If \mathbf{E}_i and \mathbf{g}_i are the coordinate basis vectors for the same material point in $\mathcal{R}_{\mathcal{R}}$ and \mathcal{R}_t , respectively, then

$$\mathbf{g}_i = \mathbf{F}\mathbf{E}_i \quad , \quad \mathbf{g}^i = \mathbf{F}^{T-1}\mathbf{E}^i \quad , \quad \mathbf{g}^i \cdot \mathbf{g}_j = \delta^i_j \quad , \quad (11.59)$$

$$g_{ij} = \mathbf{g}_i \cdot \mathbf{g}_j = \mathbf{E}_i \cdot \mathbf{C}\mathbf{E}_j \quad , \quad g^{ij} = \mathbf{g}^i \cdot \mathbf{g}^j = \mathbf{E}^i \cdot \mathbf{C}^{-1}\mathbf{E}^j \quad . \quad (11.60)$$

Between the two basis fields $\{\mathbf{e}_i\}$ and $\{\mathbf{g}_i\}$, assigned to the manifold \mathcal{R}_t , there are the relations

$$\mathbf{g}_j = \frac{\partial x^i}{\partial X^j} \mathbf{e}_i \quad , \quad \mathbf{g}^i = \frac{\partial X^i}{\partial x^j} \mathbf{e}^j \quad . \quad (11.61)$$

This, together with the formula $\mathbf{e}^k \frac{\partial}{\partial x^k} = \mathbf{e}^k \frac{\partial X^m}{\partial x^k} \frac{\partial}{\partial X^m}$, imply

$$\mathbf{e}^k \frac{\partial}{\partial x^k} = \mathbf{g}^m \frac{\partial}{\partial X^m} \quad . \quad (11.62)$$

Then,

$$\mathbf{F} = F^i_j \mathbf{e}_i \otimes \mathbf{E}^j = \delta^i_j \mathbf{g}_i \otimes \mathbf{E}^j \quad , \quad F^i_j \equiv F_{ij} = \frac{\partial x^i}{\partial X^j} \quad , \quad (11.63)$$

$$\mathbf{F}^{-1} = (\mathbf{F}^{-1})^i_j \mathbf{E}_i \otimes \mathbf{e}^j = \delta^i_j \mathbf{g}_i \otimes \mathbf{E}^j \quad , \quad (\mathbf{F}^{-1})^i_j \equiv (\mathbf{F}^{-1})_{ij} = \frac{\partial X^i}{\partial x^j} \quad . \quad (11.64)$$

In analogy to (11.59), (11.60), an additional basis field $\boldsymbol{\varrho}_i = \boldsymbol{\varrho}_i(\mathbf{x}, t)$ may be introduced on \mathcal{R}_t , by

$$\boldsymbol{\varrho}_i := \mathbf{f}\mathbf{E}_i \quad , \quad \boldsymbol{\varrho}^i := \mathbf{f}^{T-1}\mathbf{E}^i \quad , \quad \boldsymbol{\varrho}^i \cdot \boldsymbol{\varrho}_j = \delta^i_j \quad . \quad (11.65)$$

Note that, in opposite to $\{\mathbf{g}_i\}$, the basis $\{\boldsymbol{\varrho}_i\}$ is anholonomic, since \mathbf{f} does not satisfy some compatibility conditions with respect to the coordinates $\{X^i\}$. In other words, \mathbf{f} may be thought to be only a local deformation for the macroscopic body.

11.3.4 Strain energy function in micromorphic hyperelasticity

The definition of kinematical measures typical for micromorphic continua can be motivated by considering first pure elasticity. Suppose the specific (per unit mass of the macroscopic continuum) strain energy function Ψ for an elastic micromorphic material to depend on \mathbf{F} , \mathbf{f} , and GRADf ,

$$\Psi = \bar{\Psi}(\mathbf{F}, \mathbf{f}, \text{GRADf}) \quad . \quad (11.66)$$

It is worth regarding, that GRADf introduces an internal length into the theory. According to Eq. (11.66), an elastic micromorphic continuum models microphysical properties of the real material by taking into account, beyond the classical deformation gradient tensor \mathbf{F} , the microdeformation gradient tensor \mathbf{f} and its gradient GRADf (see Eringen [45]).

With respect to the convective coordinate system $\{X^i\}$, we have

$$\text{GRADf} = \frac{\partial \mathbf{f}}{\partial \mathbf{X}} = \frac{\partial \mathbf{f}}{\partial X^i} \otimes \mathbf{E}^i \quad . \quad (11.67)$$

In view of (11.52), the third-order tensor GRADf obeys the transformation law

$$(\text{GRADf})^* \equiv \text{GRAD}(\mathbf{Qf}) = \mathbf{Q} \frac{\partial \mathbf{f}}{\partial X^k} \otimes \mathbf{E}^k = \mathbf{Q} \text{GRADf} \quad , \quad (11.68)$$

where, as usual, $\mathbf{X}^* \equiv \mathbf{X}$ has been assumed. On requiring $\Psi^* = \bar{\Psi}(\mathbf{F}^*, \mathbf{f}^*, \text{GRADf}^*) = \Psi$, we get

$$\Psi = \bar{\Psi}(\mathbf{QF}, \mathbf{Qf}, \mathbf{Q} \text{GRADf}) \quad , \quad (11.69)$$

which must hold for every proper orthogonal \mathbf{Q} . By setting $\mathbf{Q} = \mathbf{r}^{-1}$,

$$\Psi = \bar{\Psi}(\mathbf{r}^{-1}\mathbf{F}, \mathbf{u}, \mathbf{r}^{-1}\text{GRADf}) = \bar{\Psi}(\mathbf{uf}^{-1}\mathbf{F}, \mathbf{u}, \mathbf{uf}^{-1}\text{GRADf}) = \bar{\bar{\Psi}}(\mathbf{f}^{-1}\mathbf{F}, \mathbf{u}^2, \mathbf{f}^{-1}\text{GRADf}) \quad , \quad (11.70)$$

or

$$\Psi = \tilde{\Psi}(\tilde{\boldsymbol{\epsilon}}, \tilde{\boldsymbol{\beta}}, \tilde{\boldsymbol{\mathcal{K}}}) \quad , \quad (11.71)$$

where

$$\tilde{\boldsymbol{\epsilon}} := \mathbf{f}^{-1}\mathbf{F} - \mathbf{1} \quad , \quad \tilde{\boldsymbol{\beta}} := \frac{1}{2}(\mathbf{u}^2 - \mathbf{1}) \quad , \quad \tilde{\boldsymbol{\mathcal{K}}} := \mathbf{f}^{-1}\text{GRADf} = \mathbf{f}^{-1} \frac{\partial \mathbf{f}}{\partial X^k} \otimes \mathbf{E}^k \quad . \quad (11.72)$$

Variables $\tilde{\boldsymbol{\epsilon}}$, $\tilde{\boldsymbol{\beta}}$, and $\tilde{\boldsymbol{\mathcal{K}}}$ are Lagrangean measures, which represent a second-order micromorphic strain tensor, a second-order classical strain tensor for the microstructure and a third-order micromorphic curvature tensor, respectively. This set of variables has been introduced by Eringen (see, e.g. Eringen [46, p. 15]) in order to formulate micromorphic elasticity. Especially, $\tilde{\boldsymbol{\mathcal{K}}}$ is called by Eringen the wryness tensor. Note that Eq. (11.72) is not the only set of variables appropriate for formulating the constitutive theory. Alternatives arise by setting in (11.69) \mathbf{Q} equal to \mathbf{r}^T or \mathbf{R}^{-1} or \mathbf{R}^T . Then, by following similar steps as above, one can readily prove that the sets (cf. Eringen [46, p. 14 and 15])

$$\left(\mathbf{f}^{-1}\mathbf{F} - \mathbf{1}, \frac{1}{2}(\mathbf{u}^2 - \mathbf{1}), \mathbf{F}^{-1}\text{GRADf} \right) \quad , \quad (11.73)$$

$$\left(\mathbf{f}^T\mathbf{F} - \mathbf{1}, \frac{1}{2}(\mathbf{u}^2 - \mathbf{1}), \mathbf{f}^T\text{GRADf} \right) \quad , \quad (11.74)$$

$$\left(\mathbf{f}^T \mathbf{F} - \mathbf{1}, \frac{1}{2}(\mathbf{u}^2 - \mathbf{1}), \mathbf{F}^{-1} \text{GRAD} \mathbf{f} \right) , \quad (11.75)$$

$$\left(\mathbf{f}^T \mathbf{F} - \mathbf{1}, \frac{1}{2}(\mathbf{U}^2 - \mathbf{1}), \mathbf{F}^T \text{GRAD} \mathbf{f} \right) , \quad (11.76)$$

$$\left(\mathbf{f}^T \mathbf{F} - \mathbf{1}, \frac{1}{2}(\mathbf{U}^2 - \mathbf{1}), \mathbf{f}^{-1} \text{GRAD} \mathbf{f} \right) , \quad (11.77)$$

$$\left(\mathbf{F}^{-1} \mathbf{f} - \mathbf{1}, \frac{1}{2}(\mathbf{U}^2 - \mathbf{1}), \mathbf{F}^{-1} \text{GRAD} \mathbf{f} \right) , \quad (11.78)$$

⋮

may also be used as Lagrangean kinematical variables for formulating constitutive theories of micromorphic elasticity.

11.4 Balance laws

11.4.1 Conservation of mass for the micro- and the macroscopic continuum

Let $V'(\mathbf{X})$, $v'(\mathbf{x}, t)$ be the volumes of the space ranges $\mathcal{R}'_{\mathcal{R}}(\mathbf{X})$ and $\mathcal{R}'_t(\mathbf{x})$, respectively. In the ensuing analysis we shall often suppress the argument \mathbf{X} in functions $V'(\mathbf{X})$, $\mathcal{R}'_{\mathcal{R}}(\mathbf{X})$, the argument \mathbf{x} in function $\mathcal{R}'_t(\mathbf{x})$, the arguments \mathbf{x}, t in function $v'(\mathbf{x}, t)$, the arguments \mathbf{X}, t in function $\mathbf{f}(\mathbf{X}, t)$, and so forth. Thus, for corresponding volume elements dV' and dv' , we have

$$dv' = (\det \mathbf{f}) dV' , \quad (11.79)$$

or equivalently

$$v' = (\det \mathbf{f}) V' . \quad (11.80)$$

The mass in the microcontinuum at \mathbf{X} , which models a neighborhood around \mathbf{X} of the real material, is assumed to be continuously distributed, so that a mass density $\varrho'(\mathbf{x}, \mathbf{x}', t)$ is assigned to each point in $\mathcal{R}'_t(\mathbf{x})$, the corresponding mass density in $\mathcal{R}'_{\mathcal{R}}(\mathbf{X})$ being $\varrho'_{\mathcal{R}}(\mathbf{X}, \mathbf{X}') \equiv \varrho'(\mathbf{X}, \mathbf{X}', 0)$. Conservation of mass for the microcontinuum is assumed to apply, so that

$$\varrho'(\mathbf{x}, \mathbf{x}', t) = \frac{\varrho'_{\mathcal{R}}(\mathbf{X}, \mathbf{X}')}{\det \mathbf{f}(\mathbf{X}, t)} . \quad (11.81)$$

Let dV , $\varrho_{\mathcal{R}}(\mathbf{X})$ be the volume element and the mass density of the macroscopic continuum in the reference configuration at point \mathbf{X} . Denote by dv the corresponding volume element in the actual configuration at point \mathbf{x} . Then

$$dv = (\det \mathbf{F}) dV . \quad (11.82)$$

The volumes of $\mathcal{R}_{\mathcal{R}}$ and \mathcal{R}_t are denoted by V and v , respectively.

We suppose $\varrho_{\mathcal{R}}$ to be given by the volume average

$$\varrho_{\mathcal{R}}(\mathbf{X}) = \langle \varrho'_{\mathcal{R}}(\mathbf{X}, \mathbf{X}') \rangle_{\mathcal{R}'_{\mathcal{R}}} := \frac{1}{V'} \int_{\mathcal{R}'_{\mathcal{R}}} \varrho'_{\mathcal{R}}(\mathbf{X}, \mathbf{X}') dV' . \quad (11.83)$$

The mass density of the macroscopic continuum in the actual configuration is referred to as $\varrho(\mathbf{x}, t)$, and conservation of mass for the macroscopic continuum is required,

$$\varrho(\mathbf{x}, t) = \frac{\varrho_{\mathcal{R}}(\mathbf{X})}{\det \mathbf{F}(\mathbf{X}, t)} \quad . \quad (11.84)$$

The latter, together with (11.79)–(11.83) yields

$$\varrho(\mathbf{x}, t) = \langle \varrho'(\mathbf{x}, \mathbf{x}', t) \rangle_{\mathcal{R}'_t} := \frac{1}{v'} \int_{\mathcal{R}'_t} \chi(\mathbf{x}, t) \varrho'(\mathbf{x}, \mathbf{x}', t) dv' \quad , \quad (11.85)$$

with the weight function χ being defined by

$$\chi(\mathbf{x}, t) := \frac{\det \mathbf{f}(\mathbf{X}, t)}{\det \mathbf{F}(\mathbf{X}, t)} \quad . \quad (11.86)$$

In other words, the mass density of the macroscopic continuum is given by the weighted volume average of the mass density of the microcontinuum. The weight function χ captures both the deformation of the macroscopic continuum and the deformation of the microcontinuum. On the other hand, one may think the mass density of the macroscopic continuum to be defined by (11.85). Then, as $\varrho'(\mathbf{X}, \mathbf{X}', 0) = \varrho'_{\mathcal{R}}(\mathbf{X}, \mathbf{X}')$, $v'(\mathbf{X}, 0) = V'(\mathbf{X})$, $\mathbf{f}(\mathbf{X}, 0) = \mathbf{F}(\mathbf{X}, 0) = \mathbf{1}$, and hence $\chi(\mathbf{X}, 0) = 1$, we see that $\varrho(\mathbf{X}, 0) = \varrho_{\mathcal{R}}(\mathbf{X})$, with $\varrho_{\mathcal{R}}(\mathbf{X})$ given by (11.83), and Eq. (11.84) will be recovered.

11.4.2 Balance laws of momentum and moment of momentum

By taking into account the motion of the microcontinuum, Mindlin [122] elaborated rigorous derivations for the balance laws for momentum (linear moment) and moment of momentum (angular moment) for the case of small deformations. Following steps similar to those in Mindlin's approach, but adjusted to the finite deformation version of the theory adopted here, one may derive in \mathcal{R}_t , relative to the Cartesian coordinate system $\{x_i\}$, the balance of momentum

$$\frac{\partial T_{ij}}{\partial x_j} + b_i = \varrho \ddot{x}_i \quad \text{in } \mathcal{R}_t \quad , \quad (11.87)$$

the balance of moment of momentum

$$\frac{\partial \mathcal{T}_{ijk}}{\partial x_k} + T_{ij} - \Sigma_{ij} + b_{ij}^{(d)} = \varrho \lambda_{ij} \quad \text{in } \mathcal{R}_t \quad , \quad (11.88)$$

and appropriate boundary conditions. (For reasons of completeness, the proof of this assertion is given in Sect. 11.6). In (11.87), (11.88), $\text{div} \mathbf{S} = \frac{\partial S_{ij}}{\partial x_j} \mathbf{e}_i$ for an Eulerian second-order tensor field $\mathbf{S} = \mathbf{S}(\mathbf{x})$, $\mathbf{T} = T_{ij} \mathbf{e}_i \otimes \mathbf{e}_j$ is the Cauchy stress tensor (non-symmetric), $\mathbf{\Sigma} = \Sigma_{ij} \mathbf{e}_i \otimes \mathbf{e}_j$ is a symmetric stress tensor responsible for the microcontinuum, $\mathcal{T} = \mathcal{T}_{ijk} \mathbf{e}_i \otimes \mathbf{e}_j \otimes \mathbf{e}_k$ is a so-called double stress tensor, $\mathbf{b} = b_i \mathbf{e}_i$ and $\mathbf{b}^{(d)} = b_{ij}^{(d)} \mathbf{e}_i \otimes \mathbf{e}_j$ are, respectively, the body force and the double body force per unit volume of the actual configuration of the macroscopic continuum, and $\mathbf{t} = t_i \mathbf{e}_i$, $\mathbf{t}^{(d)} = t_{ij}^{(d)} \mathbf{e}_i \otimes \mathbf{e}_j$ are, respectively, the surface force (traction) and the double surface force (double traction) per unit area of the actual configuration of the macroscopic continuum. The second-order tensor $\boldsymbol{\lambda}$ is defined by

$$\boldsymbol{\lambda}(\mathbf{x}, t) := \frac{1}{v'} \int_{\mathcal{R}'_t} \ddot{\mathbf{x}}' \otimes \mathbf{x}' dv' \quad , \quad (11.89)$$

if $\mathbf{X}' = \mathbf{0}$ is volume centroid of the microcontinuum in the reference configuration, or by

$$\boldsymbol{\lambda}(\mathbf{x}, t) := \frac{1}{\varrho(\mathbf{x}, t)v'} \int_{\mathcal{R}'_t} \chi(\mathbf{x}, t)(\ddot{\mathbf{x}}' \otimes \mathbf{x}') \varrho'(\mathbf{x}, \mathbf{x}', t) dv' \quad , \quad (11.90)$$

if $\mathbf{X}' = \mathbf{0}$ is center of mass of the microcontinuum in the reference configuration. Tensor $\boldsymbol{\lambda}$ in (11.89) or (11.90) is called specific (per unit mass of the microscopic continuum) spin inertia tensor. It is analogously but not equal to a corresponding tensor introduced by Eringen and Suhubi [49]. Note that $\boldsymbol{\lambda}$ obeys the representation (see Sect. 11.6)

$$\boldsymbol{\lambda} = (\mathbf{i} + \mathbb{I})\boldsymbol{\theta} \quad , \quad (11.91)$$

with

$$\boldsymbol{\theta} = \mathbf{f}\boldsymbol{\Theta}\mathbf{f}^T \quad (11.92)$$

and

$$\boldsymbol{\Theta} = \boldsymbol{\Theta}(\mathbf{X}) := \frac{1}{V'} \int_{\mathcal{R}'_{\mathcal{R}}} (\mathbf{X}' \otimes \mathbf{X}') dV' = \boldsymbol{\Theta}^T \quad , \quad (11.93)$$

$$\boldsymbol{\theta} = \boldsymbol{\theta}(\mathbf{x}, t) := \frac{1}{v'} \int_{\mathcal{R}'_t} (\mathbf{x}' \otimes \mathbf{x}') dv' = \boldsymbol{\theta}^T \quad , \quad (11.94)$$

if $\mathbf{X}' = \mathbf{0}$ is volume centroid of the microcontinuum in the reference configuration, or

$$\boldsymbol{\Theta} = \boldsymbol{\Theta}(\mathbf{X}) := \frac{1}{\varrho_{\mathcal{R}}(\mathbf{X})V'} \int_{\mathcal{R}'_{\mathcal{R}}} (\mathbf{X}' \otimes \mathbf{X}') \varrho'_{\mathcal{R}}(\mathbf{X}, \mathbf{X}') dV' \quad , \quad (11.95)$$

$$\boldsymbol{\theta} = \boldsymbol{\theta}(\mathbf{x}, t) := \frac{1}{\varrho(\mathbf{x}, t)v'} \int_{\mathcal{R}'_t} \chi(\mathbf{x}, t)(\mathbf{x}' \otimes \mathbf{x}') \varrho'(\mathbf{x}, \mathbf{x}', t) dv' \quad , \quad (11.96)$$

if $\mathbf{X}' = \mathbf{0}$ is center of mass of the microcontinuum in the reference configuration. Again, the tensors $\boldsymbol{\Theta}$, $\boldsymbol{\theta}$ defined by (11.93), (11.94) or (11.95), (11.96) are in essence the same as the so-called microinertia tensors introduced by Eringen (see, e.g. [46, p. 32]). Furthermore, starting from the motion of a microcontinuum included in each material particle of the macroscopic continuum, Eringen and Suhubi (see, e.g. [49]) proposed, by using different approaches than Mindlin, balance laws of momentum and moment of momentum for the macroscopic continuum, and related boundary conditions. If one chooses a fixed form for $\boldsymbol{\Theta} = \boldsymbol{\Theta}(\mathbf{X})$ in (11.92), then, regardless of the way $\boldsymbol{\Theta}$ is defined, these laws are exactly the same as those in (11.87), (11.88). Also, for small deformations, apart from definition of $\boldsymbol{\Theta}$, relations (11.87), (11.88) are exactly the same relations obtained by Mindlin [122] for a material composed wholly of unit cells.

11.4.3 Balance of mechanical energy

It is well known in continuum mechanics that the balance law of mechanical energy is derivable from the balance laws of momentum and moment of momentum (cf. corresponding relations in [46, 49]). Since the resulting equation is important for our aims, and in order to make the paper self-contained, we discuss briefly the derivation of this balance law.

We take the product of Eq. (11.87) (respectively, Eq. (11.88)) with \dot{x}_i (respectively, l_{ij}):

$$\frac{\partial T_{ij}}{\partial x_j} \dot{x}_i + b_i \dot{x}_i = \varrho \ddot{x}_i \dot{x}_i = \frac{1}{2} \varrho \frac{d}{dt} (\dot{x}_i \dot{x}_i) \quad , \quad (11.97)$$

$$\frac{\partial \mathcal{T}_{ijk}}{\partial x_k} l_{ij} + T_{ij} l_{ij} - \Sigma_{ij} l_{ij} + b_{ij}^{(d)} l_{ij} = \varrho \lambda_{ij} l_{ij} \quad . \quad (11.98)$$

Employing the identities

$$\frac{\partial T_{ij}}{\partial x_j} \dot{x}_i = \frac{\partial (T_{ij} \dot{x}_i)}{\partial x_j} - T_{ij} L_{ij} \quad , \quad (11.99)$$

$$\frac{\partial \mathcal{T}_{ijk}}{\partial x_k} l_{ij} = \frac{\partial (\mathcal{T}_{ijk} l_{ij})}{\partial x_k} - \mathcal{T}_{ijk} (\text{grad} \mathbf{l})_{ijk} \quad , \quad (11.100)$$

and integrating (11.97), (11.98) over \mathcal{R}_t (with boundary $\partial \mathcal{R}_t$), followed by the use of the divergence theorem,

$$\int_{\partial \mathcal{R}_t} \mathbf{t} \cdot \dot{\mathbf{x}} da + \int_{\mathcal{R}_t} \mathbf{b} \cdot \dot{\mathbf{x}} dv = \frac{d}{dt} \int_{\mathcal{R}_t} \frac{1}{2} (\dot{\mathbf{x}} \cdot \dot{\mathbf{x}}) \varrho dv + \int_{\mathcal{R}_t} \mathbf{T} \cdot \mathbf{L} dv \quad , \quad (11.101)$$

$$\int_{\partial \mathcal{R}_t} \mathbf{t}^{(d)} \cdot \mathbf{l} da + \int_{\mathcal{R}_t} \mathbf{b}^{(d)} \cdot \mathbf{l} dv = \int_{\mathcal{R}_t} \boldsymbol{\lambda} \cdot \mathbf{l} \varrho dv + \int_{\mathcal{R}_t} (\boldsymbol{\Sigma} - \mathbf{T}) \cdot \mathbf{l} dv + \int_{\mathcal{R}_t} \boldsymbol{\mathcal{T}} \cdot \text{grad} \mathbf{l} dv \quad . \quad (11.102)$$

We write $d\mathbf{A} = d\mathbf{A}\mathbf{n}_R$ for a material surface element of the macroscopic continuum at \mathbf{X} in \mathcal{R}_R , the corresponding material surface element at \mathbf{x} in \mathcal{R}_t being $d\mathbf{a} = d\mathbf{a}\mathbf{n}$, where \mathbf{n}_R and \mathbf{n} are the (positive) unit normals to the boundaries of \mathcal{R}_R and \mathcal{R}_t , respectively. After adding Eq. (11.101) to Eq. (11.102),

$$\begin{aligned} & \int_{\partial \mathcal{R}_t} (\mathbf{t} \cdot \dot{\mathbf{x}} + \mathbf{t}^{(d)} \cdot \mathbf{l}) da + \int_{\mathcal{R}_t} (\mathbf{b} \cdot \dot{\mathbf{x}} + \mathbf{b}^{(d)} \cdot \mathbf{l}) dv \\ &= \int_{\mathcal{R}_t} \left[\frac{1}{2} \frac{d}{dt} (\dot{\mathbf{x}} \cdot \dot{\mathbf{x}}) + \boldsymbol{\lambda} \cdot \mathbf{l} \right] \varrho dv + \int_{\mathcal{R}_t} [\mathbf{T} \cdot (\mathbf{L} - \mathbf{1}) + \boldsymbol{\Sigma} \cdot \mathbf{l} + \boldsymbol{\mathcal{T}} \cdot \text{grad} \mathbf{l}] dv \quad , \end{aligned} \quad (11.103)$$

which is the resulting balance of mechanical energy. The terms on the left-hand side represent the rate of working of the external (applied) forces. The first integral on the right-hand side is the rate of change of the kinetic energy of the body and

$$\int_{\mathcal{R}_t} [\mathbf{T} \cdot (\mathbf{L} - \mathbf{1}) + \boldsymbol{\Sigma} \cdot \mathbf{l} + \boldsymbol{\mathcal{T}} \cdot \text{grad} \mathbf{l}] dv = \int_{\mathcal{R}_R} [\mathbf{S} \cdot (\mathbf{L} - \mathbf{1}) + \boldsymbol{\sigma} \cdot \mathbf{l} + \boldsymbol{\mathcal{S}} \cdot \text{grad} \mathbf{l}] dV \quad , \quad (11.104)$$

is the rate of working of the internal forces, where

$$\mathbf{S} := (\det \mathbf{F}) \mathbf{T} \quad , \quad \boldsymbol{\sigma} := (\det \mathbf{F}) \boldsymbol{\Sigma} \quad , \quad \boldsymbol{\mathcal{S}} := (\det \mathbf{F}) \boldsymbol{\mathcal{T}} \quad (11.105)$$

are the weighted Cauchy stress tensor, the weighted stress tensor for the microcontinuum and the weighted double stress tensor, respectively. From Eq. (11.104), we recognize that

$$w := \mathbf{S} \cdot (\mathbf{L} - \mathbf{1}) \quad , \quad w' := \boldsymbol{\sigma} \cdot \mathbf{l} \equiv \boldsymbol{\sigma} \cdot \mathbf{d} \quad , \quad w_c := \boldsymbol{\mathcal{S}} \cdot \text{grad} \mathbf{l} \quad (11.106)$$

represent stress powers per unit volume of the reference configuration.

11.5 Dual Variables

11.5.1 Equivalent classes of strain and micromorphic curvature tensors

In this section we shall interpret geometrically the set of kinematical variables $\tilde{\boldsymbol{\epsilon}}$, $\tilde{\boldsymbol{\beta}}$ and $\tilde{\boldsymbol{\mathcal{K}}}$ appearing in Eq. (11.72). To this end we shall made use of scalar valued differences of geometrical measures.

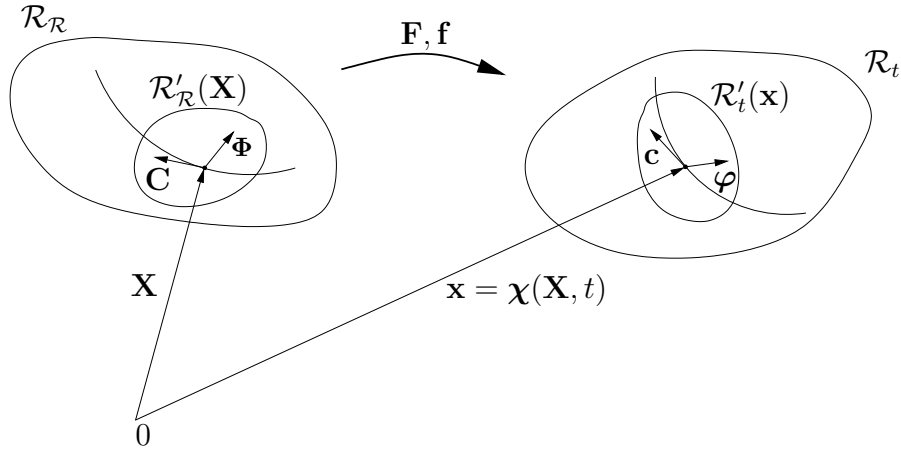

Figure 11.2: $\mathbf{F}(\mathbf{X}, t)$, $\mathbf{f}(\mathbf{X}, t)$ are two-point deformation tensors, mapping vectors at \mathbf{X} in the reference configuration to vectors at \mathbf{x} in the actual configuration.

The interpretation of other sets of variables like these in Eqs. (11.73)–(11.78) will be established in a similar fashion.

Consider a material line on \mathcal{R}_R passing through an arbitrary point \mathbf{X} and having there tangent vector $\mathbf{C} = \mathbf{C}(\mathbf{X})$ (see Fig. 11.2). The corresponding tangent vector on the same material line on \mathcal{R}_t at $\mathbf{x} = \chi(\mathbf{X}, t)$ is $\mathbf{c} = \mathbf{c}(\mathbf{x}, t)$. Further, assume $\mathbf{\Phi} = \mathbf{\Phi}(\mathbf{X})$ to be a vector at \mathbf{X} , which is position vector to some material point $\mathcal{X}' \in \mathcal{R}'_R(\mathbf{X})$, the corresponding vector at $\mathbf{x} = \chi(\mathbf{X}, t)$ being $\mathbf{\varphi}(\mathbf{x}, t)$. Then,

$$\mathbf{c} = \mathbf{F}\mathbf{C} \quad , \quad \mathbf{\varphi} = \mathbf{f}\mathbf{\Phi} \quad . \quad (11.107)$$

On the other hand, one may consider vectors $\mathbf{\Xi} = \mathbf{\Xi}(\mathbf{X})$ and $\mathbf{Z} = \mathbf{Z}(\mathbf{X})$, which are normal at \mathbf{X} , to material surfaces in the macroscopic and the microscopic continuum, respectively. The corresponding vectors normal to the same material surfaces in the actual configuration are respectively $\mathbf{\xi} = \mathbf{\xi}(\mathbf{x}, t)$ and $\mathbf{\zeta} = \mathbf{\zeta}(\mathbf{x}, t)$ and we have

$$\mathbf{\xi} = \mathbf{F}^{T-1}\mathbf{\Xi} \quad , \quad \mathbf{\zeta} = \mathbf{f}^{T-1}\mathbf{Z} \quad . \quad (11.108)$$

More generally, one can consider regular linear transformations $\mathbf{F}_a = \mathbf{F}_a(\mathbf{X}, t)$ for the macroscopic continuum, and regular linear transformations $\mathbf{f}_a = \mathbf{f}_a(\mathbf{X}, t)$ for the microscopic continuum, both going from the reference to the same, but otherwise arbitrary configuration. On designating the counterparts of \mathbf{C} , $\mathbf{\Phi}$, $\mathbf{\Xi}$, \mathbf{Z} with respect to these configurations, respectively, by \mathbf{c}_a , $\mathbf{\varphi}_a$, $\mathbf{\xi}_a$, $\mathbf{\zeta}_a$,

$$\mathbf{c}_a = \mathbf{F}_a\mathbf{C} \quad , \quad \mathbf{\varphi}_a = \mathbf{f}_a\mathbf{\Phi} \quad , \quad (11.109)$$

$$\mathbf{\xi}_a = \mathbf{F}_a^{T-1}\mathbf{\Xi} \quad , \quad \mathbf{\zeta}_a = \mathbf{f}_a^{T-1}\mathbf{Z} \quad . \quad (11.110)$$

Particular examples of such transformations are discussed in Part II in the framework of multiplicative decompositions of \mathbf{F} and \mathbf{f} into elastic and plastic parts.

11.5.1.1 Strain tensors

As in classical continuum mechanics, the state of strain in the microstructure at $\mathbf{x} = \boldsymbol{\chi}(\mathbf{X}, t)$, for fixed time t , may be expressed in terms of the scalar valued difference

$$\Delta'_s = \Delta'_s(\mathbf{X}, t) := \frac{1}{2}(\boldsymbol{\varphi} \cdot \boldsymbol{\varphi} - \boldsymbol{\Phi} \cdot \boldsymbol{\Phi}) \quad . \quad (11.111)$$

With respect to the reference configuration, on using Eq. (11.107)₂, we have

$$\Delta'_s = \boldsymbol{\Phi} \cdot \tilde{\boldsymbol{\beta}} \boldsymbol{\Phi} \quad , \quad (11.112)$$

where

$$\tilde{\boldsymbol{\beta}} := \frac{1}{2}(\mathbf{f}^T \mathbf{f} - \mathbf{1}) \quad (11.113)$$

represents a Green strain tensor for the microstructure. Various counterparts of $\tilde{\boldsymbol{\beta}}$ may be introduced by requiring from Δ'_s to remain form-invariant with respect to the chosen configuration. (This method for defining strain tensors has been discussed intensively in Haupt and Tsakmakis [82]). For example, relative to the actual configuration,

$$\Delta'_s = \boldsymbol{\varphi} \cdot \boldsymbol{\beta} \boldsymbol{\varphi} \quad , \quad (11.114)$$

where

$$\boldsymbol{\beta} := \mathbf{f}^{T-1} \tilde{\boldsymbol{\beta}} \mathbf{f}^{-1} \equiv \frac{1}{2}(\mathbf{1} - \mathbf{v}^{-2}) \quad (11.115)$$

is Eulerian counterpart of $\tilde{\boldsymbol{\beta}}$, and is called Almansi strain tensor (for the microstructure). An equivalence class of strain tensors $\boldsymbol{\beta}_a$ may be generated by representing Δ'_s with respect to configurations induced by $\mathbf{F}_a, \mathbf{f}_a$,

$$\Delta'_s = \boldsymbol{\varphi}_a \cdot \boldsymbol{\beta}_a \boldsymbol{\varphi}_a \quad , \quad \boldsymbol{\beta}_a = \mathbf{f}_a^{T-1} \tilde{\boldsymbol{\beta}} \mathbf{f}_a^{-1} \quad . \quad (11.116)$$

In other words, Δ'_s is represented form-invariantly, with respect to configurations induced by \mathbf{f}_a , by means of the strain tensors $\boldsymbol{\beta}_a$, which are obtained by push-forward transformations of $\tilde{\boldsymbol{\beta}}$.

In order to interpret the micromorphic strain tensor $\tilde{\boldsymbol{\epsilon}}$, we enter into relation the deformations of the micro- and the macrocontinuum by introducing the scalar valued difference

$$\Delta_s = \Delta_s(\mathbf{X}, t) := \boldsymbol{\zeta} \cdot \mathbf{c} - \mathbf{Z} \cdot \mathbf{C} \quad . \quad (11.117)$$

Then, by virtue of (11.107)₁ and (11.108)₂, we get relative to the reference configuration

$$\Delta_s = \mathbf{Z} \cdot \tilde{\boldsymbol{\epsilon}} \mathbf{C} \quad . \quad (11.118)$$

With respect to arbitrary configurations induced by $\mathbf{F}_a, \mathbf{f}_a$, we have

$$\Delta_s = \boldsymbol{\zeta}_a \cdot \boldsymbol{\epsilon}_a \mathbf{c}_a \quad . \quad (11.119)$$

The strain tensors $\boldsymbol{\epsilon}_a$ are defined by the push-forward transformations

$$\boldsymbol{\epsilon}_a = \mathbf{f}_a \tilde{\boldsymbol{\epsilon}} \mathbf{F}_a^{-1} \quad , \quad (11.120)$$

and form an equivalence class of micromorphic strain tensors. For the particular choice $\mathbf{f}_a = \mathbf{f}$, $\mathbf{F}_a = \mathbf{F}$, we obtain the Eulerian micromorphic strain tensor

$$\boldsymbol{\epsilon} := \mathbf{f}\tilde{\boldsymbol{\epsilon}}\mathbf{F}^{-1} = \mathbf{f}(\mathbf{f}^{-1}\mathbf{F} - \mathbf{1})\mathbf{F}^{-1} = \mathbf{1} - \mathbf{f}\mathbf{F}^{-1} \quad , \quad (11.121)$$

for which

$$\Delta_s = \boldsymbol{\zeta} \cdot \boldsymbol{\epsilon} \boldsymbol{\epsilon} \quad . \quad (11.122)$$

It is perhaps of interest to remark, that as $\boldsymbol{\Phi}(\mathbf{X})$, $\mathbf{Z}(\mathbf{X}) \in T_{\mathbf{X}}\mathcal{R}_{\mathcal{R}}$, $\tilde{\boldsymbol{\beta}}$, $\tilde{\boldsymbol{\epsilon}}$ can be imagined as second-order tensor fields on $\mathcal{R}_{\mathcal{R}}$, i.e. $\tilde{\boldsymbol{\beta}}(\mathbf{X}, t)$, $\tilde{\boldsymbol{\epsilon}}(\mathbf{X}, t) : T_{\mathbf{X}}\mathcal{R}_{\mathcal{R}} \times T_{\mathbf{X}}\mathcal{R}_{\mathcal{R}} \rightarrow \mathbb{R}$. Similarly, $\boldsymbol{\beta}$, $\boldsymbol{\epsilon}$ are second-order tensor fields on \mathcal{R}_t , i.e. $\boldsymbol{\beta}(\mathbf{x}, t)$, $\boldsymbol{\epsilon}(\mathbf{x}, t) : T_{\mathbf{x}}\mathcal{R}_t \times T_{\mathbf{x}}\mathcal{R}_t \rightarrow \mathbb{R}$ and so on.

As mentioned at the beginning of Sect. 11.5.1, all strain tensors may be introduced geometrically by considering appropriate scalar valued differences like Δ'_s and Δ_s . For example, the micromorphic strain tensors in the sets (11.73)–(11.78) can be obtained by considering, relative to the reference configuration, differences of the form

$$\boldsymbol{\varphi} \cdot \mathbf{c} - \boldsymbol{\Phi} \cdot \mathbf{C} \quad , \quad \boldsymbol{\xi} \cdot \boldsymbol{\varphi} - \boldsymbol{\Xi} \cdot \boldsymbol{\Phi} \quad , \quad \dots \quad . \quad (11.123)$$

11.5.1.2 Micromorphic curvature tensors

For interpreting geometrically the micromorphic curvature tensor $\tilde{\mathcal{K}}$ (see Eq. (11.72)₃), suppose \mathcal{X}'_i , $i = 1, 2, 3$, to be mutually different material points of the microstructure attached to \mathcal{X} , which are not all in a plane, and are different that \mathcal{X} . Let $\boldsymbol{\Phi}_i = \boldsymbol{\Phi}_i(\mathbf{X}) \equiv \mathbf{X}'_i$ be the (position) vectors assigned to the pairs $(\mathcal{X}, \mathcal{X}'_i)$. Clearly, $\boldsymbol{\Phi}_i$ are three time- and linear independent vectors (directors) at \mathbf{X} ($\boldsymbol{\Phi}_i \in T_{\mathbf{X}}\mathcal{R}_{\mathcal{R}}$), which form a basis at \mathbf{X} , the reciprocal basis being $\boldsymbol{\Phi}^i = \boldsymbol{\Phi}^i(\mathbf{X})$, $\boldsymbol{\Phi}^i \cdot \boldsymbol{\Phi}_j = \delta^i_j$. On the other hand, $\boldsymbol{\Phi}_i$ may be thought to be tangent vectors to material lines of the microstructure at \mathbf{X} . Then, the reduced convective basis for the microcontinuum at \mathbf{x} will be given by

$$\boldsymbol{\varphi}_i = \boldsymbol{\varphi}_i(\mathbf{x}, t) = \mathbf{f}\boldsymbol{\Phi}_i \in T_{\mathbf{x}}\mathcal{R}_t \quad , \quad (11.124)$$

with reciprocal basis

$$\boldsymbol{\varphi}^i = \boldsymbol{\varphi}^i(\mathbf{x}, t) = \mathbf{f}^{T-1}\boldsymbol{\Phi}^i \in T_{\mathbf{x}}\mathcal{R}_t \quad . \quad (11.125)$$

In the particular case where $\boldsymbol{\Phi}_i = \mathbf{E}_i$, the basis $\{\boldsymbol{\varphi}_i\}$ will coincide with the basis $\{\boldsymbol{\varrho}_i\}$ (cf. Eq. (11.65)). However, in the following it is convenient to left $\{\boldsymbol{\Phi}_i\}$ arbitrary. Evidently, the basis fields $\boldsymbol{\varphi}_i(\mathbf{x}, t)$ and $\boldsymbol{\Phi}_i(\mathbf{X})$, induced by the convective coordinate systems in the microstructure, can be invoked to characterize the deformation of the microcontinuum. This is analogous to the macrocontinuum, the deformation of which can be reflected by the basis vector fields $\mathbf{E}_i(\mathbf{X})$ and $\mathbf{g}_i(\mathbf{x}, t)$, induced by the convective coordinate system $\{X^i\}$.

Next, we define a scalar-valued difference Δ_c by

$$\Delta_c = \Delta_c(\mathbf{X}, t) := \boldsymbol{\varphi}^1 \cdot (\nabla_{\mathcal{R}_t}\boldsymbol{\varphi}_2)[\mathbf{g}_3] - \boldsymbol{\Phi}^1 \cdot (\nabla_{\mathcal{R}_{\mathcal{R}}}\boldsymbol{\Phi}_2)[\mathbf{E}_3] \quad , \quad (11.126)$$

where

$$\nabla_{\mathcal{R}_t}\boldsymbol{\varphi}_2 := \text{grad}\boldsymbol{\varphi}_2 = \frac{\partial\boldsymbol{\varphi}_2}{\partial X^k} \otimes \mathbf{g}^k \quad , \quad (11.127)$$

$$\nabla_{\mathcal{R}_R} \Phi_2 := \text{GRAD} \Phi_2 = \frac{\partial \Phi_2}{\partial X^k} \otimes \mathbf{E}^k \quad . \quad (11.128)$$

Δ_c is a measure for the deformation of the microstructure at a material point, which takes into account the deformation of the microstructure assigned to points in the neighborhood.

Our aim is to represent Δ_c first by means of the curvature tensor $\tilde{\mathcal{K}}$. To this end we express φ^1 , φ_2 and \mathbf{g}_3 in Eq. (11.126) in terms of Φ^1 , Φ_2 and \mathbf{E}_3 ,

$$\begin{aligned} \Delta_c &= \mathbf{f}^{T-1} \Phi^1 \cdot \left(\frac{\partial(\mathbf{f}\Phi_2)}{\partial X^k} \otimes \mathbf{g}^k \right) [\mathbf{g}_3] - \Phi^1 \cdot \left(\frac{\partial \Phi_2}{\partial X^k} \otimes \mathbf{E}^k \right) [\mathbf{E}_3] \\ &= \Phi^1 \cdot \left\{ \mathbf{f}^{-1} \frac{\partial \mathbf{f}}{\partial X^k} \Phi_2 \right\} (\mathbf{g}^k \cdot \mathbf{g}_3) + \Phi^1 \cdot \frac{\partial \Phi_2}{\partial X^k} (\mathbf{g}^k \cdot \mathbf{g}_3) - \Phi^1 \cdot \frac{\partial \Phi_2}{\partial X^k} (\mathbf{E}^k \cdot \mathbf{E}_3) \quad , \end{aligned} \quad (11.129)$$

or, in view of $\mathbf{g}^k \cdot \mathbf{g}_3 = \mathbf{E}^k \cdot \mathbf{E}_3$,

$$\Delta_c = \Phi^1 \cdot \left(\mathbf{f}^{-1} \frac{\partial \mathbf{f}}{\partial X^k} \Phi_2 \right) (\mathbf{E}^k \cdot \mathbf{E}_3) = \left(\mathbf{f}^{-1} \frac{\partial \mathbf{f}}{\partial X^k} \otimes \mathbf{E}^k \right) [\Phi^1, \Phi_2, \mathbf{E}_3] \quad . \quad (11.130)$$

Hence, (cf. definition (11.72)₃)

$$\Delta_c = \tilde{\mathcal{K}}[\Phi^1, \Phi_2, \mathbf{E}_3] \quad . \quad (11.131)$$

It is straightforward to verify that, with respect to the actual configuration,

$$\Delta_c = \mathcal{K}[\varphi^1, \varphi_2, \mathbf{g}_3] \quad , \quad (11.132)$$

where

$$\mathcal{K} := \frac{\partial \mathbf{f}}{\partial X^k} \mathbf{f}^{-1} \otimes \mathbf{g}^k \equiv (\text{grad} \mathbf{f}) \diamond \mathbf{f}^{-1} \quad (11.133)$$

and

$$\mathcal{K} = \mathcal{L}(\mathbf{f}, \mathbf{f}^{T-1}, \mathbf{F}^{T-1})[\tilde{\mathcal{K}}] \quad . \quad (11.134)$$

That means, \mathcal{K} can be derived from $\tilde{\mathcal{K}}$ by push-forward transformation generated by $\mathcal{L}(\mathbf{f}, \mathbf{f}^{T-1}, \mathbf{F}^{T-1})$.

Result (11.134) can be generalized to arbitrary configurations induced by the deformations \mathbf{F}_a , \mathbf{f}_a . In fact, if we define

$$(\mathbf{g}_a)_k := \mathbf{F}_a \mathbf{E}_k \quad , \quad (\mathbf{g}_a)^k = \mathbf{F}_a^{T-1} \mathbf{E}^k \quad , \quad (11.135)$$

$$(\varphi_a)_k := \mathbf{f}_a \Phi_k \quad , \quad (\varphi_a)^k = \mathbf{f}_a^{T-1} \Phi^k \quad , \quad (11.136)$$

then an equivalence class of tensors \mathcal{K}_a can be constructed, such that

$$\Delta_c = \mathcal{K}_a[(\varphi_a)^1, (\varphi_a)_2, (\mathbf{g}_a)_3] \quad (11.137)$$

and

$$\mathcal{K}_a = \mathcal{L}(\mathbf{f}_a, \mathbf{f}_a^{T-1}, \mathbf{F}_a^{T-1})[\tilde{\mathcal{K}}] \quad (11.138)$$

or

$$\tilde{\mathcal{K}} = \mathcal{L}(\mathbf{f}_a^{-1}, \mathbf{f}_a^T, \mathbf{F}_a^T)[\mathcal{K}_a] \quad . \quad (11.139)$$

Especially, for $\mathbf{F}_a = \mathbf{F}$ and $\mathbf{f}_a = \mathbf{f}$,

$$\mathcal{K}_{mnr} = (\mathbf{f})_{mi}(\mathbf{f}^{T-1})_{nj}(\mathbf{F}^{T-1})_{rk}\tilde{\mathcal{K}}_{ijk} \quad , \quad (11.140)$$

$$\tilde{\mathcal{K}}_{mnr} = (\mathbf{f}^{-1})_{mi}(\mathbf{f}^T)_{nj}(\mathbf{F}^T)_{rk}\mathcal{K}_{ijk} \quad , \quad (11.141)$$

with respect to the Cartesian coordinate systems $\{X_i\}$ for $\mathcal{R}_{\mathcal{R}}$ and $\{x_i\}$ for \mathcal{R}_t , inducing the basis $\{\mathbf{E}_i\}$ and $\{\mathbf{e}_i\}$, respectively. Evidently, $\tilde{\mathcal{K}}(\mathbf{X}, t)$ is a third-order tensor on $\mathcal{R}_{\mathcal{R}}$, $\mathcal{K}(\mathbf{x}, t)$ is a third-order tensor on \mathcal{R}_t , and so on.

Summarizing, by representing the scalar differences Δ'_s , $\hat{\Delta}_s$ and Δ_c in a form-invariant manner with respect to the chosen configuration, equivalent classes of strain tensors for the microcontinuum, micromorphic strain tensors and micromorphic curvature tensors can be obtained. This also provides the geometrical interpretation of the considered set of strain and curvature tensors. The geometrical interpretation of other sets of variables can be established in a similar fashion. However, in the remaining of this paper, and in Part II, we shall concentrate ourself on the equivalent classes of strain and curvature tensors produced by the set of variables in (11.72). This set of variables is also favored by Eringen [46, p. 15 and 16]. For the tensors in these equivalent classes, we shall show how to find out associated time derivatives and dual stresses. For other sets of variables the approach will be quite similar.

11.5.2 Associated rates for strain and micromorphic curvature tensors

For every strain or micromorphic curvature tensor, a specific rate (associated rate) may be uniquely determined by requiring from $\hat{\Delta}'_s$, $\hat{\Delta}_s$, and $\hat{\Delta}_c$ to remain also form-invariant with respect to the chosen configuration (cf. Haupt and Tsakmakis [82] for similar approaches in classical continuum mechanics). It is worth mentioning that this method for assigning to each strain or micromorphic curvature tensor an associated rate is independent of particular material properties.

To illustrate the method, we restrict attention to Δ'_s , take the material time derivative of (11.111), (11.114) or (11.116), and summarize the results as follows

$$\hat{\Delta}'_s = \Phi \cdot \overset{\Delta}{\beta} \Phi \quad , \quad \overset{\Delta}{\beta} := \dot{\beta} \quad , \quad (11.142)$$

$$\hat{\Delta}'_s = \varphi \cdot \overset{\Delta}{\beta} \varphi \quad , \quad \overset{\Delta}{\beta} := \dot{\beta} + \mathbf{l}^T \beta + \beta \mathbf{l} = \mathbf{d} \quad , \quad (11.143)$$

or generally

$$\hat{\Delta}'_s = \varphi_a \cdot \overset{\Delta}{\beta}_a \varphi_a \quad , \quad \overset{\Delta}{\beta}_a := \dot{\beta}_a + (\dot{\mathbf{f}}_a \mathbf{f}_a^{-1})^T \beta_a + \beta_a (\dot{\mathbf{f}}_a \mathbf{f}_a^{-1}) \quad . \quad (11.144)$$

We refer to $\overset{\Delta}{\beta}_a$ as the rate associated to β_a . Obviously, $\hat{\Delta}'_s$, like Δ'_s , is represented form-invariantly with respect to the chosen configuration. To each strain β_a , operating in configurations generated by \mathbf{F}_a , \mathbf{f}_a , there is assigned a specific rate $\overset{\Delta}{\beta}_a$, which represents a generalized Oldroyd time derivative. With respect to the reference configuration, the associated rate is the material time derivative, while relative to the actual configuration, the associated rate corresponds to a classical Oldroyd derivative. It is of interest, and also of practical importance, to remark that the associated rates $\overset{\Delta}{\beta}_a$ arise from the rate $\dot{\beta}$ by the same push-forward transformations as between β_a and $\tilde{\beta}$ (cf. Eq. (11.116)₂,

$$\overset{\Delta}{\beta}_a = \mathbf{f}_a^{T-1} \dot{\beta} \mathbf{f}_a^{-1} \quad . \quad (11.145)$$

Without proof, we mention that under rigid body rotations superposed on the configuration induced by \mathbf{F}_a , \mathbf{f}_a , $\hat{\beta}_a$ transforms like β_a . Moreover, higher associated rates may be introduced by postulating the time rates $\dot{\Delta}'_s, \dot{\Delta}''_s, \dots$ to be form-invariant with respect to the chosen configuration as well. This means, our approach for introducing associated rates is the same as that one used to construct the well known Rivlin-Ericksen tensors (see Malvern [116, p. 403]).

In a similar way, Eqs. (11.117)–(11.122) yield

$$\dot{\Delta}_s = \mathbf{Z} \cdot \hat{\epsilon} \mathbf{C} \quad , \quad \hat{\epsilon} := \dot{\epsilon} \quad , \quad (11.146)$$

$$\dot{\Delta}_s = \zeta \cdot \hat{\epsilon} \mathbf{c} \quad , \quad \hat{\epsilon} := \dot{\epsilon} - \mathbf{l}\epsilon + \epsilon \mathbf{L} = \mathbf{L} - \mathbf{l} = \mathbf{f} \dot{\epsilon} \mathbf{F}^{-1} \quad , \quad (11.147)$$

or generally

$$\dot{\Delta}_s = \zeta_a \cdot \hat{\epsilon}_a \mathbf{c}_a \quad , \quad \hat{\epsilon}_a := \dot{\epsilon}_a - (\dot{\mathbf{f}}_a \mathbf{f}_a^{-1}) \epsilon_a + \epsilon_a (\dot{\mathbf{F}}_a \mathbf{F}_a^{-1}) = \mathbf{f}_a \dot{\epsilon} \mathbf{F}_a^{-1} \quad . \quad (11.148)$$

For the associated rates of micromorphic curvature tensors, we deduce from Eqs. (11.131)–(11.141)

$$\dot{\Delta}_c = \hat{\mathcal{K}}[\Phi^1, \Phi_2, \mathbf{E}_3] \quad , \quad \hat{\mathcal{K}} := \dot{\mathcal{K}} \quad , \quad (11.149)$$

$$\dot{\Delta}_c = \hat{\mathcal{K}}[\varphi^1, \varphi_2, \mathbf{g}_3] \quad , \quad \hat{\mathcal{K}} := \dot{\mathcal{K}} - \mathbf{l}\mathcal{K} + \mathbf{l}^T \diamond \mathcal{K} + \mathcal{K}\mathbf{l} = \text{grad l} = \mathcal{L}(\mathbf{f}, \mathbf{f}^{T-1}, \mathbf{F}^{T-1})[\dot{\mathcal{K}}] \quad . \quad (11.150)$$

With respect to the orthonormal bases $\{\mathbf{E}_i\}$ and $\{\mathbf{e}_i\}$, induced by the Cartesian coordinate systems $\{X_i\}$ for $\mathcal{R}_{\mathcal{R}}$ and $\{x_i\}$ for \mathcal{R}_t ,

$$\dot{\mathcal{K}}_{ijm} = \left((\mathbf{f}^{-1})_{ir} \frac{\partial f_{rj}}{\partial X_m} \right) \dot{\quad} = (\mathbf{f}^{-1})_{ir} (\mathbf{f}^T)_{jp} (\mathbf{F}^T)_{ms} \frac{\partial l_{rp}}{\partial x_s} \quad , \quad (11.151)$$

$$\hat{\mathcal{K}}_{kln} = (\mathbf{f})_{ki} (\mathbf{f}^{T-1})_{lj} (\mathbf{F}^{T-1})_{nm} \dot{\mathcal{K}}_{ijm} = \frac{\partial l_{kl}}{\partial x_n} \quad . \quad (11.152)$$

More generally,

$$\dot{\Delta}_c = \hat{\mathcal{K}}_a[(\varphi_a)^1, (\varphi_a)_2, (\mathbf{g}_a)_3] \quad , \quad (11.153)$$

$$\hat{\mathcal{K}}_a = \dot{\mathcal{K}}_a - (\dot{\mathbf{f}}_a \mathbf{f}_a^{-1}) \mathcal{K}_a + (\dot{\mathbf{f}}_a \mathbf{f}_a^{-1})^T \diamond \mathcal{K}_a + \mathcal{K}_a (\dot{\mathbf{F}}_a \mathbf{F}_a^{-1}) = \mathcal{L}(\mathbf{f}_a, \mathbf{f}_a^{T-1}, \mathbf{F}_a^{T-1})[\dot{\mathcal{K}}] \quad . \quad (11.154)$$

Of course, higher rates for the micromorphic strain and the micromorphic curvature tensors may be introduced in a natural manner, by requiring from the rates $\dot{\Delta}_s, \dot{\Delta}''_s, \dots, \dot{\Delta}_c, \dot{\Delta}''_c, \dots$ to be form-invariant with respect to the chosen configuration. Concluding, we remark that also for the micromorphic strain and the micromorphic curvature tensors, the associated rates transform, under rigid body rotations superposed on the configuration induced by \mathbf{F}_a , \mathbf{f}_a , as the tensors themselves.

11.5.3 Dual stress tensors and their associated rates

Generally, strain and stress tensors are not a priori related to each other, raising the question of whether there exists a method to connect with each strain tensor a stress tensor independently of specific material properties. The stress power is commonly the convenient framework for answering this

question. In the context of classical continuum mechanics, Hill [85] developed the concept of conjugate variables on the basis of the stress power \bar{w} (e.g., per unit volume of reference configuration). According to this, a stress tensor is postulated to be conjugate to a given strain tensor \mathbf{e} , if the scalar product of \mathbf{t} with the material time derivative of \mathbf{e} yields the stress power \bar{w} ,

$$\bar{w} = \mathbf{t} \cdot \dot{\mathbf{e}} \quad . \quad (11.155)$$

Hill's conjugacy concept is meaningful only for Lagrangean variables. In fact, for the Eulerian Cauchy stress tensor a conjugate strain tensor does not exist (see, e.g. Ogden [134, p.159]). To overcome this difficulty in classical continuum mechanics, Haupt and Tsakmakis [82] proposed the concept of dual variables. We shall adopt this concept and we shall extend it to cover micromorphic continua as well. For simplicity, we shall define the notion dual variables only with reference to the three classes of strain and micromorphic curvature tensors introduced in Sect. (11.5.1). But it is emphasized that for other classes one has to go on analogously.

We first concentrate ourself to the class of strain tensors β_a and discuss in full length the main issues of the concept. Recall that for defining these tensors and their associated rates, use is made of the scalar quantities $\Delta'_s, \dot{\Delta}'_s, \dots$. These scalars were required to be form-invariant with respect to the chosen configuration. Now, we consider the stress power w' defined by (11.106)₂, and its rates $\dot{w}', \ddot{w}', \dots$, and require from these scalar quantities to be also form-invariant with respect to the chosen configuration. Keeping in mind (11.143), it follows that

$$w' = \boldsymbol{\sigma} \cdot \overset{\Delta}{\beta} \quad (11.156)$$

relative to the actual configuration, or

$$w' = \boldsymbol{\sigma} \cdot \mathbf{f}^{T-1} \dot{\beta} \mathbf{f}^{-1} = \mathbf{f}^{-1} \boldsymbol{\sigma} \mathbf{f}^{T-1} \cdot \dot{\beta} \quad , \quad (11.157)$$

and therefore

$$w' = \tilde{\boldsymbol{\sigma}} \cdot \dot{\beta} \quad (11.158)$$

relative to the reference configuration, where (cf. Eq. (11.226))

$$\tilde{\boldsymbol{\sigma}} = \mathbf{f}^{-1} \boldsymbol{\sigma} \mathbf{f}^{T-1} \quad (11.159)$$

represents a second Piola-Kirchhoff stress tensor for the microcontinuum. Substituting $\dot{\beta}$ from (11.145) into (11.158),

$$w' = \mathbf{f}_a \tilde{\boldsymbol{\sigma}} \mathbf{f}_a^T \cdot \overset{\Delta}{\beta}_a \quad . \quad (11.160)$$

On defining the stress tensor $\boldsymbol{\sigma}_a$ through

$$\boldsymbol{\sigma}_a := \mathbf{f}_a \tilde{\boldsymbol{\sigma}} \mathbf{f}_a^T \quad , \quad (11.161)$$

we obtain, with respect to configurations generated by $\mathbf{F}_a, \mathbf{f}_a$,

$$w' = \boldsymbol{\sigma}_a \cdot \overset{\Delta}{\beta}_a \quad . \quad (11.162)$$

The latter reveals that w' exhibits a form-invariant representation with respect to every configuration induced by $\mathbf{F}_a, \mathbf{f}_a$. If $\mathbf{F}_a = \mathbf{f}_a = \mathbf{1}$ (reference configuration), then w' is given by (11.158), while for

$\mathbf{F}_a = \mathbf{F}$ and $\mathbf{f}_a = \mathbf{f}$ (actual configuration) w' is given by (11.156). Pairs $(\boldsymbol{\beta}_a, \boldsymbol{\sigma}_a)$ of strain and stress tensors satisfying (11.162) are said to be dual strain and stress tensors (with respect to w').

To determine the time derivative which is associated with the stress tensor $\boldsymbol{\sigma}_a$, we take the material time derivative of w' in (11.158),

$$\dot{w}' = \dot{\tilde{\boldsymbol{\sigma}}} \cdot \dot{\tilde{\boldsymbol{\beta}}} + \tilde{\boldsymbol{\sigma}} \cdot \ddot{\tilde{\boldsymbol{\beta}}} \quad . \quad (11.163)$$

Using the stress tensors $\boldsymbol{\sigma}_a$ and the strain tensors $\boldsymbol{\beta}_a$, the term $\tilde{\boldsymbol{\sigma}} \cdot \ddot{\tilde{\boldsymbol{\beta}}}$ can be written in the form

$$\tilde{\boldsymbol{\sigma}} \cdot \ddot{\tilde{\boldsymbol{\beta}}} = \boldsymbol{\sigma}_a \cdot \overset{\Delta\Delta}{\boldsymbol{\beta}}_a \quad , \quad (11.164)$$

where

$$\overset{\Delta\Delta}{\boldsymbol{\beta}}_a = \mathbf{f}_a^T \ddot{\tilde{\boldsymbol{\beta}}} \mathbf{f}_a^{-1} = (\overset{\Delta}{\boldsymbol{\beta}}_a) \cdot + (\dot{\mathbf{f}}_a \mathbf{f}_a^{-1})^T \overset{\Delta}{\boldsymbol{\beta}}_a + \overset{\Delta}{\boldsymbol{\beta}}_a (\dot{\mathbf{f}}_a \mathbf{f}_a^{-1}) \quad . \quad (11.165)$$

Clearly, Eq. (11.164) represents a scalar, which is expressible form-invariantly with respect to the chosen configuration. Consequently, the scalar

$$w'_{incr.} := \dot{\tilde{\boldsymbol{\sigma}}} \cdot \dot{\tilde{\boldsymbol{\beta}}} \quad , \quad (11.166)$$

which is called the incremental stress power (per unit volume of the reference configuration) for the microcontinuum, must also be form-invariant with respect to the chosen configuration. Because,

$$w'_{incr.} = \dot{\tilde{\boldsymbol{\sigma}}} \cdot \mathbf{f}_a^T \overset{\Delta}{\boldsymbol{\beta}}_a \mathbf{f}_a = \mathbf{f}_a \dot{\tilde{\boldsymbol{\sigma}}} \mathbf{f}_a^T \cdot \overset{\Delta}{\boldsymbol{\beta}}_a \quad , \quad (11.167)$$

w' will be form-invariant,

$$w'_{incr.} = \overset{\nabla}{\boldsymbol{\sigma}}_a \cdot \overset{\Delta}{\boldsymbol{\beta}}_a \quad , \quad (11.168)$$

whenever

$$\overset{\nabla}{\boldsymbol{\sigma}}_a := \dot{\boldsymbol{\sigma}}_a - (\dot{\mathbf{f}}_a \mathbf{f}_a^{-1}) \boldsymbol{\sigma}_a - \boldsymbol{\sigma}_a (\dot{\mathbf{f}}_a \mathbf{f}_a^{-1})^T = \mathbf{f}_a \dot{\tilde{\boldsymbol{\sigma}}} \mathbf{f}_a^T \quad . \quad (11.169)$$

If $\mathbf{F}_a = \mathbf{F}$, $\mathbf{f}_a = \mathbf{f}$ (actual configuration), then

$$\overset{\nabla}{\boldsymbol{\sigma}} = \dot{\boldsymbol{\sigma}} - \mathbf{l}\boldsymbol{\sigma} - \boldsymbol{\sigma}\mathbf{l}^T \quad . \quad (11.170)$$

This way, we can associate with each stress tensor $\boldsymbol{\sigma}_a$ a specific time derivative $\overset{\nabla}{\boldsymbol{\sigma}}_a$, which is referred to as associated rate. Concerning the properties of the rates $\overset{\nabla}{\boldsymbol{\sigma}}_a$, it is easy to prove that under rigid body rotations superposed on the configurations induced by \mathbf{F}_a , \mathbf{f}_a , $\overset{\nabla}{\boldsymbol{\sigma}}_a$ transform like $\boldsymbol{\sigma}_a$. Also, Eqs. (11.169) and (11.161) suggest that $\overset{\nabla}{\boldsymbol{\sigma}}_a$ arises from $\dot{\tilde{\boldsymbol{\sigma}}}$ by the same push-forward transformation as between $\boldsymbol{\sigma}_a$ and $\tilde{\boldsymbol{\sigma}}$.

The method for determining stress tensors dual to the micromorphic strains $\boldsymbol{\epsilon}_a$, as well as associated rates, is quite similar. The main results read as follows,

$$w = \tilde{\mathbf{S}} \cdot \dot{\tilde{\boldsymbol{\epsilon}}} = \mathbf{S} \cdot \overset{\Delta}{\boldsymbol{\epsilon}} = \mathbf{S}_a \cdot \overset{\Delta}{\boldsymbol{\epsilon}}_a \quad , \quad (11.171)$$

with (cf. (11.226))

$$\mathbf{S} = \mathbf{f}^{T-1} \tilde{\mathbf{S}} \mathbf{F}^T \quad , \quad (11.172)$$

or generally

$$\mathbf{S}_a := \mathbf{f}_a^{T-1} \tilde{\mathbf{S}} \mathbf{F}_a^T \quad . \quad (11.173)$$

\mathbf{S}_a is called dual to $\boldsymbol{\epsilon}_a$. The associated rates $\overset{\nabla}{\mathbf{S}}_a$ are given by

$$\overset{\nabla}{\mathbf{S}}_a = \mathbf{f}_a^{T-1} \dot{\tilde{\mathbf{S}}} \mathbf{F}_a^T = \dot{\mathbf{S}}_a + (\dot{\mathbf{f}}_a \mathbf{f}_a^{-1})^T \mathbf{S}_a - \mathbf{S}_a (\dot{\mathbf{F}}_a \mathbf{F}_a^{-1})^T \quad . \quad (11.174)$$

For $\mathbf{F}_a = \mathbf{F}$, $\mathbf{f}_a = \mathbf{f}$ (actual configuration)

$$\overset{\nabla}{\mathbf{S}} = \mathbf{f}^{T-1} \dot{\tilde{\mathbf{S}}} \mathbf{F}^T = \dot{\mathbf{S}} + \mathbf{l}^T \mathbf{S} - \mathbf{S} \mathbf{L}^T \quad . \quad (11.175)$$

Finally, for the double stress tensors dual to the micromorphic curvature tensors, we have

$$w_c = \tilde{\mathbf{S}} \cdot \dot{\hat{\mathbf{K}}} = \mathbf{S} \cdot \hat{\dot{\mathbf{K}}} = \mathbf{S}_a \cdot \hat{\dot{\mathbf{K}}}_a \quad , \quad (11.176)$$

with (cf. (11.226))

$$\mathbf{S} = \mathcal{L}(\mathbf{f}^{T-1}, \mathbf{f}, \mathbf{F})[\tilde{\mathbf{S}}] \quad , \quad (11.177)$$

or generally

$$\mathbf{S}_a := \mathcal{L}(\mathbf{f}_a^{T-1}, \mathbf{f}_a, \mathbf{F}_a)[\tilde{\mathbf{S}}] \quad . \quad (11.178)$$

Micromorphic curvature tensors \mathbf{K}_a and double stress tensors \mathbf{S}_a are said to be dual to each other.

The associated rates $\overset{\nabla}{\mathbf{S}}_a$ are given by

$$\overset{\nabla}{\mathbf{S}}_a := \mathcal{L}(\mathbf{f}_a^{T-1}, \mathbf{f}_a, \mathbf{F}_a)[\dot{\tilde{\mathbf{S}}}] = \dot{\mathbf{S}}_a + (\dot{\mathbf{f}}_a \mathbf{f}_a^{-1}) \mathbf{S}_a - \mathbf{S}_a \diamond (\dot{\mathbf{f}}_a \mathbf{f}_a^{-1})^T - \mathbf{S}_a (\dot{\mathbf{F}}_a \mathbf{F}_a^{-1}) \quad . \quad (11.179)$$

In particular, for $\mathbf{F}_a = \mathbf{F}$ and $\mathbf{f}_a = \mathbf{f}$,

$$\overset{\nabla}{\mathbf{S}} = \mathcal{L}(\mathbf{f}^{T-1}, \mathbf{f}, \mathbf{F})[\dot{\tilde{\mathbf{S}}}] = \dot{\mathbf{S}} + \mathbf{l} \mathbf{S} - \mathbf{S} \diamond \mathbf{l}^T - \mathbf{S} \mathbf{L} \quad . \quad (11.180)$$

We shall employ in Part II the strain and micromorphic curvature tensors, as well as their corresponding dual stress tensors to formulate micromorphic plasticity.

Appendix

11.6 Derivation of balance laws for momentum and moment of momentum according to Mindlin's approach

We shall extend, from small to finite deformations, the approach of Mindlin for establishing the balance laws of momentum and moment of momentum. We start from the definition of the microcontinuum, the

kinematical relations, the equations describing conservation of mass (see Sect. 11.4.1) and Hamilton's principle. Latter is considered only for conservative mechanical systems and is equivalent to the local equations of motion, provided all functions involved are sufficiently smooth. However, although the local equations of motion will be derived in the framework of conservative systems, they still apply to every mechanical system governed by similar higher order stresses. Consequently, they can be utilized for the elastic-plastic materials addressed in Part II. Another important reason for employing this approach is to derive rigorously the local equations of motion for the macrocontinuum by using appropriate averages of the microcontinuum, as it is shown in the remainder of the paper.

Before going any further we would like to mention two articles, which come into our knowledge by one of the reviewers. The first one is of Germain [62] and deals with the virtual power method to derive relevant field equations among others also for micromorphic materials. According to this method, which has been recently applied by Forest and Sievert [55], it is not necessary for the material behavior to be hyperelastic, which makes it appear to be an advantage, or to be more general, than other energetical principles dealing with hyperelastic material behavior. However, the virtual power method requires some a priori knowledge, which may be available only through experience. The second article goes back to Chen [22] and proposes to gain the field equations from Hamilton's principle under the framework of Poisson bracket formalisms. There are some similarities between this article and our work, in what concerns the weight functions in the averaging procedures. But otherwise the article of Chen [22] relies upon Eringen's definition on microcontinuum, so that differences exist, e.g. in the definition of the spin inertia tensor.

11.6.1 Hamilton's principle for pure elastic materials

Hamilton's principle for independent variations $\delta \mathbf{u}$ and $\delta \mathbf{f}$ of displacement $\mathbf{u} := \mathbf{x} - \mathbf{X}$ and microdeformation \mathbf{f} , and fixed times t_0, t_1 , reads

$$\delta \left(\int_{t_0}^{t_1} K dt + \int_{t_0}^{t_1} W_e dt \right) = \delta \int_{t_0}^{t_1} W dt \quad , \quad (11.181)$$

or

$$\int_{t_0}^{t_1} \delta K dt + \int_{t_0}^{t_1} \delta W_e dt = \int_{t_0}^{t_1} \delta W dt \quad . \quad (11.182)$$

Here, K and W_e are the total kinetic energy and the work done by external forces for the macrocontinuum, respectively, while W designates the work of the internal forces. Variations $\delta \mathbf{u}$ and $\delta \mathbf{f}$, as well as quantities K, W_e, W are defined in the following sections. In doing this, it suffices to concentrate oneself on the Cartesian coordinates $\{x_i\}$ for \mathcal{R}_t and $\{X_i\}$ for $\mathcal{R}_{\mathcal{R}}$, inducing the orthonormal bases $\{\mathbf{e}_i\}$ and $\{\mathbf{E}_i\}$, respectively. All tensorial components are referred to these coordinate systems.

11.6.2 Variation of \mathbf{u} and \mathbf{f}

Let $\partial \mathcal{R}_t$ be the boundary of \mathcal{R}_t , and denote by $\partial \mathcal{R}_t^{u_i}$ the part of $\partial \mathcal{R}_t$ where the displacement components u_i are prescribed, $u_i = \bar{u}_i$ on $\partial \mathcal{R}_t^{u_i}$. Variations $\delta \mathbf{u} = \delta \mathbf{u}(\mathbf{x}, t)$ are defined to be, as sufficiently as needed, smooth functions vanishing on $\partial \mathcal{R}_t^{u_i}$, i.e. $\delta u_i = 0$ on $\partial \mathcal{R}_t^{u_i}$. Moreover, $\delta \mathbf{u}$ have to vanish everywhere at times t_0 and t_1 , $\delta \mathbf{u} \equiv \mathbf{0}$ in \mathcal{R}_{t_0} or \mathcal{R}_{t_1} .

Let $\partial\mathcal{R}_t^{f_{ij}}$ be the part of $\partial\mathcal{R}_t$ where components of the microdeformation f_{ij} are prescribed, $f_{ij} = \bar{f}_{ij}$ on $\partial\mathcal{R}_t^{f_{ij}}$. Variations $\delta\mathbf{f} = \delta\mathbf{f}(\mathbf{x}, t)$ are defined to be, as sufficiently as needed, smooth functions vanishing on $\partial\mathcal{R}_t^{f_{ij}}$, i.e. $\delta f_{ij} = 0$ on $\partial\mathcal{R}_t^{f_{ij}}$, and to satisfy $\delta\mathbf{f} = \mathbf{0}$ in \mathcal{R}_{t_0} or \mathcal{R}_{t_1} .

11.6.3 Kinetic energy of the macroscopic continuum

The total kinetic energy of the macrocontinuum is given by (cf. Mindlin [122])

$$K := \int_{\mathcal{R}_{\mathcal{R}}} T dV \equiv \int_{\mathcal{R}_t} \tau dv \quad , \quad (11.183)$$

where T is the density of kinetic energy of the macroscopic continuum at \mathbf{X} per unit volume of the reference configuration of the macroscopic continuum, and τ is the density of kinetic energy of the macroscopic continuum at \mathbf{x} per unit volume of the actual configuration of the macroscopic continuum. We define

$$T = T(\mathbf{X}, t) := \frac{1}{2} \langle \varrho'(\mathbf{X}, \mathbf{X}') \rangle_{\mathcal{R}_{\mathcal{R}}} \langle (\mathbf{x} + \mathbf{x}') \cdot (\mathbf{x} + \mathbf{x}') \rangle_{\mathcal{R}_{\mathcal{R}}} = \frac{\varrho_{\mathcal{R}}}{2} \langle (\mathbf{x} + \mathbf{x}') \cdot (\mathbf{x} + \mathbf{x}') \rangle_{\mathcal{R}_{\mathcal{R}}} \quad , \quad (11.184)$$

$$\tau = \tau(\mathbf{x}, t) := \frac{1}{2} \langle \varrho'(\mathbf{x}, \mathbf{x}', t) \rangle_{\mathcal{R}_t} \langle (\mathbf{x} + \mathbf{x}') \cdot (\mathbf{x} + \mathbf{x}') \rangle_{\mathcal{R}_t} = \frac{\varrho}{2} \langle (\mathbf{x} + \mathbf{x}') \cdot (\mathbf{x} + \mathbf{x}') \rangle_{\mathcal{R}_t} \quad , \quad (11.185)$$

where $\langle (\mathbf{x} + \mathbf{x}') \cdot (\mathbf{x} + \mathbf{x}') \rangle_{\mathcal{R}_{\mathcal{R}}}$ and $\langle (\mathbf{x} + \mathbf{x}') \cdot (\mathbf{x} + \mathbf{x}') \rangle_{\mathcal{R}_t}$ are respectively averages of squares of velocities to be defined appropriately, and use has been made of (11.83) and (11.85). In order for definitions (11.184) and (11.185) to be compatible with (11.183), we have to prove that

$$T dV = \tau dv \quad . \quad (11.186)$$

In addition, we shall show that T and τ obey the representations

$$T = \frac{\varrho_{\mathcal{R}}}{2} (\dot{\mathbf{x}} \cdot \dot{\mathbf{x}}) + \frac{\varrho_{\mathcal{R}}}{2} \dot{\mathbf{f}}^T \dot{\mathbf{f}} \cdot \Theta \quad , \quad (11.187)$$

$$\tau = \frac{\varrho}{2} (\dot{\mathbf{x}} \cdot \dot{\mathbf{x}}) + \frac{\varrho}{2} \mathbf{1}^T \mathbf{1} \cdot \theta \quad , \quad (11.188)$$

where Θ and θ are Lagrangean and Eulerian second-order tensors, respectively, to be given below. They fulfill the transformation law

$$\theta = \mathbf{f} \Theta \mathbf{f}^T \quad . \quad (11.189)$$

Proceeding to prove (11.186)–(11.189), we consider two possibilities for the material point $\mathbf{X}' = \mathbf{0}$ of the microcontinuum at \mathbf{X} .

In the first possibility, we assume this point to be the volume centroid of the microcontinuum, i.e.

$$\int_{\mathcal{R}'_{\mathcal{R}}} \mathbf{X}' dV' = \mathbf{0} \quad . \quad (11.190)$$

As the deformation of the microcontinuum is homogeneous, we have $\mathbf{X}' = \mathbf{f}^{-1} \mathbf{x}'$, so that (11.190) is equivalent to

$$\frac{1}{\det \mathbf{f}} \mathbf{f}^{-1} \int_{\mathcal{R}'_t} \mathbf{x}' dv' = \mathbf{0} \quad , \quad (11.191)$$

where (11.79) has been taken into account. Since \mathbf{f} is a regular mapping, the linear equation (11.191) possess only the trivial solution

$$\int_{\mathcal{R}'_t} \mathbf{x}' dv' = \mathbf{0} \quad . \quad (11.192)$$

In other words, the material point of the microcontinuum which is volume centroid in the reference configuration remains volume centroid in the actual configuration as well. From (11.192),

$$\frac{d}{dt} \int_{\mathcal{R}'_t} \mathbf{x}' dv' = \int_{\mathcal{R}'_t} (\dot{\mathbf{x}}' + \mathbf{x}'(\text{tr} \mathbf{l})) dv' = \mathbf{0} \quad , \quad (11.193)$$

and hence

$$\int_{\mathcal{R}'_t} \dot{\mathbf{x}}' dv' = \mathbf{0} \quad \text{or} \quad \int_{\mathcal{R}'_{\mathcal{R}}} \dot{\mathbf{x}}' dV' = \mathbf{0} \quad . \quad (11.194)$$

Now, we define

$$\langle (\mathbf{x} + \mathbf{x}') \cdot (\mathbf{x} + \mathbf{x}') \rangle_{\mathcal{R}_{\mathcal{R}}} := \frac{1}{V'} \int_{\mathcal{R}'_{\mathcal{R}}} (\mathbf{x} + \mathbf{x}') \cdot (\mathbf{x} + \mathbf{x}') dV' \quad , \quad (11.195)$$

$$\langle (\mathbf{x} + \mathbf{x}') \cdot (\mathbf{x} + \mathbf{x}') \rangle_{\mathcal{R}_t} := \frac{1}{v'} \int_{\mathcal{R}'_t} (\mathbf{x} + \mathbf{x}') \cdot (\mathbf{x} + \mathbf{x}') dv' \quad . \quad (11.196)$$

It follows from (11.184), (11.185), by virtue of (11.194), that

$$T = T(\mathbf{X}, t) = \frac{\varrho \mathcal{R}(\mathbf{X})}{2} \left\{ \frac{1}{V'} \int_{\mathcal{R}'_{\mathcal{R}}} (\mathbf{x} + \mathbf{x}') \cdot (\mathbf{x} + \mathbf{x}') dV' \right\} = \frac{\varrho \mathcal{R}}{2} (\dot{\mathbf{x}} \cdot \dot{\mathbf{x}}) + \frac{\varrho \mathcal{R}}{2} \left\{ \frac{1}{V'} \int_{\mathcal{R}'_{\mathcal{R}}} (\dot{\mathbf{x}}' \cdot \dot{\mathbf{x}}') dV' \right\} \quad , \quad (11.197)$$

and

$$\tau = \tau(\mathbf{x}, t) = \frac{\varrho(\mathbf{x}, t)}{2} \left\{ \frac{1}{v'} \int_{\mathcal{R}'_t} (\mathbf{x} + \mathbf{x}') \cdot (\mathbf{x} + \mathbf{x}') dv' \right\} = \frac{\varrho}{2} (\dot{\mathbf{x}} \cdot \dot{\mathbf{x}}) + \frac{\varrho}{2} \left\{ \frac{1}{v'} \int_{\mathcal{R}'_t} (\dot{\mathbf{x}}' \cdot \dot{\mathbf{x}}') dv' \right\} \quad . \quad (11.198)$$

Note in passing, that (11.197) corresponds to the kinetic energy density proposed by Mindlin [122], when "the material is composed wholly of unit cells". Also, it is not difficult (by using (11.79)–(11.86)) to verify that (11.197) and (11.198) satisfy the equivalence relation (11.186).

In order to recast T and τ , we introduce the second-order tensors Θ and θ by the volume averages

$$\Theta = \Theta(\mathbf{X}) := \frac{1}{V'} \int_{\mathcal{R}'_{\mathcal{R}}} (\mathbf{X}' \otimes \mathbf{X}') dV' = \Theta^T \quad , \quad (11.199)$$

$$\theta = \theta(\mathbf{x}, t) := \frac{1}{v'} \int_{\mathcal{R}'_t} (\mathbf{x}' \otimes \mathbf{x}') dv' = \theta^T \quad . \quad (11.200)$$

Clearly, these definitions satisfy the transformation rule (11.189), and recalling that $\dot{\mathbf{x}}' = \mathbf{l}\mathbf{x}'$, we find

$$\frac{1}{V'} \int_{\mathcal{R}'_{\mathcal{R}}} (\dot{\mathbf{x}}' \cdot \dot{\mathbf{x}}') dV' \equiv \frac{1}{v'} \int_{\mathcal{R}'_t} (\dot{\mathbf{x}}' \cdot \dot{\mathbf{x}}') dv' = \mathbf{f}^T \mathbf{f} \cdot \Theta = \mathbf{l}^T \mathbf{l} \cdot \theta \quad . \quad (11.201)$$

After inserting in (11.197) and (11.198), we get Eqs. (11.187) and (11.188), which proves the assertion in the context of the first possibility.

According to the second possibility, we assume the point $\mathbf{X}' = \mathbf{0}$ of the microcontinuum at \mathbf{X} , to be the center of mass, i.e.

$$\int_{\mathcal{R}'_{\mathcal{R}}} \mathbf{X}' \varrho'_{\mathcal{R}} dV' = \mathbf{0} \quad , \quad (11.202)$$

which is equivalent to

$$\int_{\mathcal{R}'_t} \mathbf{x}' \varrho' dv' = \mathbf{0} \quad . \quad (11.203)$$

That means, the material point of the microcontinuum which is center of mass in the reference configuration remains center of mass in every configuration during the motion of the material body. Moreover,

$$\frac{d}{dt} \int_{\mathcal{R}'_t} \mathbf{x}' \varrho' dv' = \int_{\mathcal{R}'_t} \dot{\mathbf{x}}' \varrho' dv' = \mathbf{0} \quad . \quad (11.204)$$

(These results go back to Eringen (see, e.g. [46, p. 31]).)

Now, we define

$$\langle (\mathbf{x} + \mathbf{x}') \cdot (\mathbf{x} + \mathbf{x}') \rangle_{\mathcal{R}_{\mathcal{R}}} := \frac{1}{\int_{\mathcal{R}'_{\mathcal{R}}} \varrho'_{\mathcal{R}}(\mathbf{X}, \mathbf{X}') dV'} \int_{\mathcal{R}'_{\mathcal{R}}} (\mathbf{x} + \mathbf{x}') \cdot (\mathbf{x} + \mathbf{x}') \varrho'_{\mathcal{R}}(\mathbf{X}, \mathbf{X}') dV' \quad , \quad (11.205)$$

$$\langle (\mathbf{x} + \mathbf{x}') \cdot (\mathbf{x} + \mathbf{x}') \rangle_{\mathcal{R}_t} := \frac{1}{\int_{\mathcal{R}'_t} \chi(\mathbf{x}, t) \varrho'(\mathbf{x}, \mathbf{x}', t) dv'} \int_{\mathcal{R}'_t} \chi(\mathbf{x}, t) [(\mathbf{x} + \mathbf{x}') \cdot (\mathbf{x} + \mathbf{x}')] \varrho'(\mathbf{x}, \mathbf{x}', t) dv' \quad . \quad (11.206)$$

After inserting in (11.184), (11.185), and applying (11.202)–(11.204) and the relations (cf. Eqs. (11.83), (11.85))

$$\varrho_{\mathcal{R}} V' = \int_{\mathcal{R}'_{\mathcal{R}}} \varrho'_{\mathcal{R}} dV' \quad , \quad \varrho v' = \int_{\mathcal{R}'_t} \chi \varrho' dv' \quad , \quad (11.207)$$

we conclude that

$$T = \frac{\varrho_{\mathcal{R}}}{2} \left\{ \frac{1}{\varrho_{\mathcal{R}} V'} \int_{\mathcal{R}'_{\mathcal{R}}} (\mathbf{x} + \mathbf{x}') \cdot (\mathbf{x} + \mathbf{x}') \varrho'_{\mathcal{R}} dV' \right\} = \frac{\varrho_{\mathcal{R}}}{2} (\dot{\mathbf{x}} \cdot \dot{\mathbf{x}}) + \frac{\varrho_{\mathcal{R}}}{2} \left\{ \frac{1}{\varrho_{\mathcal{R}} V'} \int_{\mathcal{R}'_{\mathcal{R}}} (\dot{\mathbf{x}}' \cdot \dot{\mathbf{x}}') \varrho'_{\mathcal{R}} dV' \right\} \quad (11.208)$$

and

$$\tau = \frac{\varrho}{2} \left\{ \frac{1}{\varrho v'} \int_{\mathcal{R}'_t} \chi (\mathbf{x} + \mathbf{x}') \cdot (\mathbf{x} + \mathbf{x}') \varrho' dv' \right\} = \frac{\varrho}{2} (\dot{\mathbf{x}} \cdot \dot{\mathbf{x}}) + \frac{\varrho}{2} \left\{ \frac{1}{\varrho v'} \int_{\mathcal{R}'_t} \chi (\dot{\mathbf{x}}' \cdot \dot{\mathbf{x}}') \varrho' dv' \right\} \quad . \quad (11.209)$$

It is easy to confirm (by using relations (11.79)–(11.86)), on the one hand, that (11.208) and (11.209) satisfy Eq. (11.186), and on the other hand, that T and τ may be represented by (11.187), (11.188), provided Θ and θ are now defined by the mass averages

$$\Theta = \Theta(\mathbf{X}) := \frac{1}{\varrho_{\mathcal{R}}(\mathbf{X}) V'(\mathbf{X})} \int_{\mathcal{R}'_{\mathcal{R}}} (\mathbf{X}' \otimes \mathbf{X}') \varrho'_{\mathcal{R}}(\mathbf{X}, \mathbf{X}') dV' = \Theta^T \quad , \quad (11.210)$$

$$\boldsymbol{\theta} = \boldsymbol{\theta}(\mathbf{x}, t) := \frac{1}{\varrho(\mathbf{x}, t)v'(\mathbf{x}, t)} \int_{\mathcal{R}'_t} \chi(\mathbf{x}, t)(\mathbf{x}' \otimes \mathbf{x}')\varrho'(\mathbf{x}, \mathbf{x}', t)dv' = \boldsymbol{\theta}^T, \quad (11.211)$$

which proves the assertion in the context of the second possibility.

Note that the second-order tensors $\boldsymbol{\Theta}$ and $\boldsymbol{\theta}$ in Eqs. (11.210), (11.211) correspond, but are not equal, to the microinertia tensors introduced by Eringen (see, e.g. [46, p. 32]).

From (11.183) and (11.187)

$$\int_{t_0}^{t_1} \delta K dt = - \int_{t_0}^{t_1} \left\{ \int_{\mathcal{R}_{\mathcal{R}}} (\varrho_{\mathcal{R}} \ddot{\mathbf{x}} \cdot \delta \mathbf{u} + \varrho_{\mathcal{R}} \boldsymbol{\Theta} \cdot \ddot{\mathbf{f}}^T \delta \mathbf{f}) dV \right\} dt, \quad (11.212)$$

where use is made of partial integration and of the fact that $\delta \mathbf{u}$ and $\delta \mathbf{f}$ vanish at times t_0 and t_1 .

Similar to Eringen [46, p. 33], we define a spin inertia second-order tensor $\boldsymbol{\lambda}$ by

$$\boldsymbol{\lambda}(\mathbf{x}, t) := \frac{1}{v'} \int_{\mathcal{R}'_t} (\ddot{\mathbf{x}}' \otimes \mathbf{x}') dv' , \quad (11.213)$$

if $\mathbf{X}' = \mathbf{0}$ is volume centroid, or by

$$\boldsymbol{\lambda}(\mathbf{x}, t) := \frac{1}{\varrho(\mathbf{x}, t)v'} \int_{\mathcal{R}'_t} \chi(\mathbf{x}, t)(\ddot{\mathbf{x}}' \otimes \mathbf{x}')\varrho'(\mathbf{x}, \mathbf{x}', t)dv' , \quad (11.214)$$

if $\mathbf{X}' = \mathbf{0}$ is center of mass. Since the microcontinuum undergoes homogeneous deformations, the relation $\ddot{\mathbf{x}}' = (\dot{\mathbf{I}} + \mathbf{II})\mathbf{x}'$ applies, so that in every case

$$\boldsymbol{\lambda} = (\dot{\mathbf{I}} + \mathbf{II})\boldsymbol{\theta} , \quad (11.215)$$

in view of (11.200) and (11.211). Further, it is readily shown that

$$\boldsymbol{\Theta} \cdot \ddot{\mathbf{f}}^T \delta \mathbf{f} = (\dot{\mathbf{I}} + \mathbf{II})\boldsymbol{\theta} \cdot (\delta \mathbf{f})\mathbf{f}^{-1} , \quad (11.216)$$

so that, after substitution in (11.212),

$$\int_{t_0}^{t_1} \delta K dt = - \int_{t_0}^{t_1} \left\{ \int_{\mathcal{R}_t} [\varrho \ddot{\mathbf{x}} \cdot \delta \mathbf{u} + \varrho \boldsymbol{\lambda} \cdot (\delta \mathbf{f})\mathbf{f}^{-1}] dv \right\} dt , \quad (11.217)$$

or,

$$\int_{t_0}^{t_1} \delta K dt = - \int_{t_0}^{t_1} \left\{ \int_{\mathcal{R}_t} [\varrho \ddot{x}_i \delta u_i + \varrho \lambda_{ij} (\delta f_{im})(\mathbf{f}^{-1})_{mj}] dv \right\} dt . \quad (11.218)$$

11.6.4 Work of the internal forces

The work of the internal forces will be stored in the material as potential energy W ,

$$W := \int_{\mathcal{R}_{\mathcal{R}}} \varrho_{\mathcal{R}} \Psi dV \equiv \int_{\mathcal{R}_t} \varrho \Psi dv , \quad (11.219)$$

with Ψ being given by (11.71). We define the second-order stress tensors

$$\tilde{\mathbf{S}} := \varrho_{\mathcal{R}} \frac{\partial \tilde{\Psi}}{\partial \tilde{\boldsymbol{\epsilon}}} , \quad \tilde{\boldsymbol{\sigma}} := \varrho_{\mathcal{R}} \frac{\partial \tilde{\Psi}}{\partial \tilde{\boldsymbol{\beta}}} = \tilde{\boldsymbol{\sigma}}^T \quad (11.220)$$

and the third-order double stress tensor

$$\tilde{\mathbf{S}} := \varrho_{\mathcal{R}} \frac{\partial \tilde{\Psi}}{\partial \tilde{\mathcal{K}}} . \quad (11.221)$$

It follows from (11.219), that

$$\delta W = \int_{\mathcal{R}_{\mathcal{R}}} (\tilde{\mathbf{S}} \cdot \delta \tilde{\boldsymbol{\varepsilon}} + \tilde{\boldsymbol{\sigma}} \cdot \delta \tilde{\boldsymbol{\beta}} + \tilde{\mathbf{S}} \cdot \delta \tilde{\mathcal{K}}) dV . \quad (11.222)$$

After some lengthy, but otherwise straightforward calculations,

$$\tilde{\mathbf{S}} \cdot \delta \tilde{\boldsymbol{\varepsilon}} = \mathbf{S} \cdot \{(\delta \mathbf{F}) \mathbf{F}^{-1} - (\delta \mathbf{f}) \mathbf{f}^{-1}\} , \quad (11.223)$$

$$\tilde{\boldsymbol{\sigma}} \cdot \delta \tilde{\boldsymbol{\beta}} = \boldsymbol{\sigma} \cdot \{(\delta \mathbf{f}) \mathbf{f}^{-1}\} , \quad (11.224)$$

$$\tilde{\mathbf{S}} \cdot \delta \tilde{\mathcal{K}} = \mathcal{S} \cdot \frac{\partial \{(\delta \mathbf{f}) \mathbf{f}^{-1}\}}{\partial \mathbf{x}} , \quad (11.225)$$

where

$$\mathbf{S} := \mathbf{f}^{T-1} \tilde{\mathbf{S}} \mathbf{F}^T , \quad \boldsymbol{\sigma} := \mathbf{f} \tilde{\boldsymbol{\sigma}} \mathbf{f}^T , \quad \mathcal{S} := \mathcal{L}(\mathbf{f}^{T-1}, \mathbf{f}, \mathbf{F})[\tilde{\mathcal{S}}] . \quad (11.226)$$

Substitution in (11.222), and integrating with respect to the actual configuration,

$$\delta W = \int_{\mathcal{R}_t} \left\{ \mathbf{T} \cdot \{(\delta \mathbf{F}) \mathbf{F}^{-1}\} - \mathbf{T} \cdot \{(\delta \mathbf{f}) \mathbf{f}^{-1}\} + \boldsymbol{\Sigma} \cdot \{(\delta \mathbf{f}) \mathbf{f}^{-1}\} + \boldsymbol{\mathcal{T}} \cdot \frac{\partial \{(\delta \mathbf{f}) \mathbf{f}^{-1}\}}{\partial \mathbf{x}} \right\} dv , \quad (11.227)$$

or equivalently

$$\delta W = \int_{\mathcal{R}_t} \left\{ T_{ij} (\delta F_{im}) (\mathbf{F}^{-1})_{mj} - T_{ij} (\delta f_{im}) (\mathbf{f}^{-1})_{mj} + \Sigma_{ij} (\delta f_{im}) (\mathbf{f}^{-1})_{mj} + \mathcal{T}_{ijk} \frac{\partial \{(\delta f_{im}) (\mathbf{f}^{-1})_{mj}\}}{\partial x_k} \right\} dv , \quad (11.228)$$

where

$$\mathbf{T} := \frac{1}{\det \mathbf{F}} \mathbf{S} , \quad \boldsymbol{\Sigma} := \frac{1}{\det \mathbf{F}} \boldsymbol{\sigma} , \quad \boldsymbol{\mathcal{T}} := \frac{1}{\det \mathbf{F}} \mathcal{S} . \quad (11.229)$$

We notice the relations

$$T_{ij} (\delta F_{im}) (\mathbf{F}^{-1})_{mj} = \frac{\partial (T_{ij} \delta u_i)}{\partial x_j} - \frac{\partial T_{ij}}{\partial x_j} \delta u_i , \quad (11.230)$$

$$\mathcal{T}_{ijk} \frac{\partial \{(\delta f_{im}) (\mathbf{f}^{-1})_{mj}\}}{\partial x_k} = \frac{\partial \{T_{ijk} (\delta f_{im}) (\mathbf{f}^{-1})_{mj}\}}{\partial x_k} - \frac{\partial T_{ijk}}{\partial x_k} (\delta f_{im}) (\mathbf{f}^{-1})_{mj} . \quad (11.231)$$

On inserting in (11.228), and employing the divergence theorem,

$$\begin{aligned} \delta W = & \int_{\mathcal{R}_t} \left(\Sigma_{ij} - T_{ij} - \frac{\partial T_{ijk}}{\partial x_k} \right) (\delta f_{im}) (\mathbf{f}^{-1})_{mj} dv - \int_{\mathcal{R}_t} \frac{\partial T_{ij}}{\partial x_j} (\delta u_i) dv \\ & + \int_{\partial \mathcal{R}_t} T_{ij} n_j (\delta u_i) da + \int_{\partial \mathcal{R}_t} T_{ijk} n_k (\delta f_{im}) (\mathbf{f}^{-1})_{mj} da . \end{aligned} \quad (11.232)$$

with $\partial \mathcal{R}_t$ being the boundary of \mathcal{R}_t .

11.6.5 Work of the external forces

As suggested by Mindlin [122], the form of (11.232) motivates to adopt the following form for δW_e ,

$$\delta W_e = \int_{\mathcal{R}_t} b_i \delta u_i dv + \int_{\mathcal{R}_t} b_{ij}^{(d)} (\delta f_{im}) (\mathbf{f}^{-1})_{mj} dv + \int_{\partial \mathcal{R}_t} t_i \delta u_i da + \int_{\partial \mathcal{R}_t} t_{ij}^{(d)} (\delta f_{im}) (\mathbf{f}^{-1})_{mj} da \quad , \quad (11.233)$$

where $\mathbf{b} = b_i \mathbf{e}_i$, $\mathbf{b}^{(d)} = b_{ij}^{(d)} \mathbf{e}_i \otimes \mathbf{e}_j$ are the body force and double body force per unit volume of the actual configuration of the macroscopic continuum and $\mathbf{t} = t_i \mathbf{e}_i$, $\mathbf{t}^{(d)} = t_{ij}^{(d)} \mathbf{e}_i \otimes \mathbf{e}_j$ are the surface force (traction) and the double surface force (double traction) per unit area of the actual configuration of the macroscopic continuum, respectively.

11.6.6 Local equations of motion

We now insert Eqs. (11.233), (11.232), and (11.218) into Eq. (11.182) and drop the integration with respect to time,

$$\begin{aligned} & \int_{\mathcal{R}_t} \left(\frac{\partial T_{ij}}{\partial x_j} + b_i - \rho \ddot{x}_i \right) \delta u_i dv \\ & + \int_{\mathcal{R}_t} \left(\frac{\partial \mathcal{T}_{ijk}}{\partial x_k} + T_{ij} - \Sigma_{ij} + b_{ij}^{(d)} - \rho \lambda_{ij} \right) (\delta f_{im}) (\mathbf{f}^{-1})_{mj} dv \\ & + \int_{\partial \mathcal{R}_t} (t_i - T_{ij} n_j) \delta u_i da + \int_{\partial \mathcal{R}_t} (t_{ij}^{(d)} - \mathcal{T}_{ijk} n_k) (\delta f_{im}) (\mathbf{f}^{-1})_{mj} da = 0 \quad . \end{aligned} \quad (11.234)$$

The necessary and sufficient conditions in order for (11.234) to be satisfied for arbitrary variations $\delta \mathbf{u}$, $\delta \mathbf{f}$, are the local equations of motion

$$\frac{\partial T_{ij}}{\partial x_j} + b_i = \rho \ddot{x}_i \quad \text{in } \mathcal{R}_t \quad , \quad (11.235)$$

$$\frac{\partial \mathcal{T}_{ijk}}{\partial x_k} + T_{ij} - \Sigma_{ij} + b_{ij}^{(d)} = \rho \lambda_{ij} \quad \text{in } \mathcal{R}_t \quad , \quad (11.236)$$

together with the boundary conditions

$$T_{ij} n_j = t_i = \bar{t}_i \quad \text{on } \partial \mathcal{R}_t^{t_i} = \partial \mathcal{R}_t \setminus \partial \mathcal{R}_t^{u_i} \quad , \quad (11.237)$$

$$\mathcal{T}_{ijk} n_k = t_{ij}^{(d)} = \bar{t}_{ij}^{(d)} \quad \text{on } \partial \mathcal{R}_t^{t_{ij}^{(d)}} = \partial \mathcal{R}_t \setminus \partial \mathcal{R}_t^{f_{ij}} \quad , \quad (11.238)$$

$$\delta u_i = 0 \quad \text{and} \quad u_i = \bar{u}_i \quad \text{on } \partial \mathcal{R}_t^{u_i} \quad , \quad (11.239)$$

$$\delta f_{ij} = 0 \quad \text{and} \quad f_{ij} = \bar{f}_{ij} \quad \text{on } \partial \mathcal{R}_t^{f_{ij}} \quad . \quad (11.240)$$

Thereby,

$$\partial \mathcal{R}_t^{u_i} \cup \partial \mathcal{R}_t^{t_i} = \partial \mathcal{R}_t \quad , \quad \partial \mathcal{R}_t^{u_i} \cap \partial \mathcal{R}_t^{t_i} = \emptyset \quad , \quad (11.241)$$

$$\partial \mathcal{R}_t^{f_{ij}} \cup \partial \mathcal{R}_t^{t_{ij}^{(d)}} = \partial \mathcal{R}_t \quad , \quad \partial \mathcal{R}_t^{f_{ij}} \cap \partial \mathcal{R}_t^{t_{ij}^{(d)}} = \emptyset \quad . \quad (11.242)$$

Concluding, we emphasize once more that relations (11.235)–(11.242) have been established here by confining to pure elasticity, but otherwise they are valid for all micromorphic materials, irrespective of particular constitutive properties.

12 Micromorphic continuum. Part II: Finite deformation plasticity coupled with damage

P. Grammenoudis, D. Hofer, Ch. Tsakmakis

International Journal of Non-Linear Mechanics, 44 (2009), 957–974

Micromorphic continuum.
Part II: Finite deformation plasticity coupled with damage

P. Grammenoudis^{*}, D. Hofer[°], Ch. Tsakmakis^{*}

**^{*}Darmstadt University of Technology, Institute of Continuum Mechanics,
Hochschulstraße 1, 64289 Darmstadt, Germany**

**[°]Westinghouse Electric Germany GmbH, Abt. PEM,
Dudenstr. 44, 68167 Mannheim, Germany**

Abstract

It is demonstrated how a micromorphic plasticity theory may be formulated on the basis of multiplicative decompositions of the macro- and microdeformation gradient tensor, respectively. The theory exhibits non-linear isotropic and non-linear kinematic hardening. The yield function is expressed in terms of Mandel stress and double stress tensors, appropriately defined for micromorphic continua. Flow rules are derived from the postulate of Il'iusin and represent generalized normality conditions. Evolution equations for isotropic and kinematic hardening are introduced as sufficient conditions for the validity of the second law of thermodynamics in every admissible process. Finally, it is sketched how isotropic damage effects may be incorporated in the theory. This is done for the concept of effective stress combined with the hypothesis of strain equivalence.

12.1 Introduction

It has been mentioned in Part I that micropolar and micromorphic materials are continuum theories which take into account, in some sense, the microstructure of the real material (continua with microstructures). Higher-order gradients of the kinematical variables are incorporated, which renders such models, among other things, to be suitable when describing localization effects. However, in opposite to micropolar continua, there are no broadly known (finite deformation) micromorphic plasticity theories. Thus the aim of Part II is to sketch how a thermodynamically consistent micromorphic plasticity theory may be formulated, by using the general framework developed in Part I.

To give an outline of the present work, we elaborate multiplicative decompositions of the macro- and microdeformation gradient tensors into elastic and plastic parts, respectively, in order to introduce a so-called plastic intermediate configuration for micromorphic continua. As in classical plasticity, this implies additive decompositions of the strain and micromorphic curvature tensors into elastic and plastic parts. It is a peculiarity of the proposed theory that the plastic part of the micromorphic curvature tensor is not related to some gradient operator and hence it is not subjected to some compatibility conditions. The formulation of the constitutive theory is based on three stress tensors, namely the Cauchy stress tensor, a stress tensor responsible for the microcontinuum and a double stress

tensor. To these stress tensors, definitions of Mandel type stress tensors are worked out and utilized to express the intrinsic dissipation inequality, as well as to represent the yield function. Correspondingly, three back-stress tensors for modeling kinematic hardening effects are assumed. Isotropic hardening can be modeled by using three different plastic arc lengths, related, respectively, to a micromorphic strain, a strain for the microcontinuum and a micromorphic curvature strain, or by capturing all strains unifiedly by means of a single plastic arc length. Here, the latter course is followed, that means, a single plastic arc length approach is chosen. Similar to classical plasticity, we assume the validity of Il'iusin's postulate, appropriately generalized for micromorphic continua, and extract from this convexity of the yield surface and normality conditions for the flow rules. The evolution equations governing the response of the hardening variables are established as sufficient conditions for the validity of the dissipation inequality in every admissible process. As mentioned above, micromorphic plasticity theories may be important when localization phenomena are investigated. In such cases, the existence of some softening mechanisms inherent in the material response is significant, as e.g. damage. The simplest case is isotropic damage described by a scalar variable. We demonstrate how isotropic damage may be coupled to the micromorphic plasticity model. To this end, use is made of the effective stress concept combined with the hypothesis of strain equivalence.

Throughout the article, the notation and the assumptions made in Part I hold. In order to make the theoretical effort as small as possible, isotropy is assumed to apply, as explained in the article.

12.2 Decompositions of deformation

12.2.1 Multiplicative decomposition of the macro- and the microdeformation gradient tensors into elastic and plastic parts

As in classical plasticity, it is assumed that the macrodeformation gradient tensor \mathbf{F} may be decomposed into elastic and plastic parts,

$$\mathbf{F} = \mathbf{F}_e \mathbf{F}_p \quad , \quad (12.1)$$

where $\det \mathbf{F}_e > 0$ is assumed, and therefore $\det \mathbf{F}_p > 0$, in view of $\det \mathbf{F} > 0$. This decomposition of \mathbf{F} has been broadly known by the works of Lee and Liu [101] and Lee [100]. Decomposition (12.1) is supposed to be unique except for a rigid body rotation (see [78, 13, 14]). In addition to (12.1), we assume the multiplicative decomposition of the microdeformation gradient tensor \mathbf{f} into elastic and plastic parts,

$$\mathbf{f} = \mathbf{f}_e \mathbf{f}_p \quad , \quad (12.2)$$

with $\det \mathbf{f}_e > 0$, and therefore $\det \mathbf{f}_p > 0$ too. Decomposition (12.2) is supposed to be also unique except for the same rigid body rotation, which may be inserted into the decomposition (12.1).

It must be mentioned that further interesting multiplicative decompositions into elastic and plastic parts have been introduced previously by Sansour [139], and later on adopted by Forest and Sievert [55]. A generalized deformation gradient $\tilde{\mathbf{F}}$ is assumed by Sansour [139] to reflect the deformation of the micro- and macrocontinuum. With respect to $\tilde{\mathbf{F}}$, two alternative multiplicative decompositions are proposed, which are not equivalent to our Equations (12.1), (12.2).

In opposite to $\mathbf{F}(\mathbf{X}, t)$, $\mathbf{F}_p(\mathbf{X}, t)$ (and therefore $\mathbf{F}_e(\mathbf{X}, t)$ too) is incompatible deformation. For fixed time t , $\mathbf{F}_p(\mathbf{X}, t)$ induces a local configuration for the macroscopic continuum at \mathbf{X} . (We adopt the

definition of local deformation and local configuration used by Noll [129] and Truesdell and Noll [155].) Let $\hat{\mathbf{x}} \in \mathcal{E}$ be the position vector, in that local configuration, of the material point, which in the reference configuration possesses the position vector \mathbf{X} . Obviously, the position $\hat{\mathbf{x}}$ can be chosen arbitrary (cf. Grammenoudis and Tsakmakis [72]). This fact may be visualized by imaging the local deformation $\mathbf{F}_p(\mathbf{X}, t)$ at \mathbf{X} to map a neighborhood $\mathcal{N}(\mathbf{X}) \in \mathcal{E}$ on a neighborhood $\hat{\mathcal{M}}(\hat{\mathbf{x}}, t) \in \mathcal{E}$ around $\hat{\mathbf{x}}$, with $\hat{\mathbf{x}}$ being an arbitrary point of \mathcal{E} . (Further aspects and details may be consulted in Grammenoudis and Tsakmakis [72, 75].) Now, as $\hat{\mathbf{x}}$ may be chosen arbitrary, we assume in particular $\hat{\mathbf{x}}$ to be given by an arbitrary deformation $\hat{\chi}$,

$$\hat{\mathbf{x}} = \hat{\chi}(\mathbf{X}, t) \quad . \quad (12.3)$$

It is emphasized that $\mathbf{F}_p(\mathbf{X}, t) \neq \frac{\partial \hat{\chi}}{\partial \mathbf{X}}$ generally. As special cases, $\hat{\mathbf{x}} \equiv \mathbf{X}$ or $\hat{\mathbf{x}} \equiv \mathbf{x}$ are allowed. In the following, the conceptual configuration introduced by deformation $\hat{\chi}(\cdot, t)$ is left arbitrary. We shall write \hat{R}_t for the range in \mathcal{E} occupied by the body under the configuration induced by $\hat{\chi}$, $\hat{R}_t = \hat{\chi}(\mathcal{R}_{\mathcal{R}}, t)$.

Configuration $\hat{\chi}(\cdot, t)$, together with a collection of local deformations for \mathbf{F}_p is referred to as plastic intermediate configuration for the macroscopic continuum. As the position vector $\hat{\mathbf{x}}$ may be chosen arbitrary, we shall say that the macroscopic continuum will deform in the plastic intermediate configuration locally by \mathbf{F}_p . While the macroscopic continuum deforms locally from \mathbf{X} to $\hat{\mathbf{x}}$, the microscopic continuum at \mathbf{X} is postulated to deform homogeneously by $\mathbf{f}_p = \mathbf{f}_p(\mathbf{X}, t)$, so that the position vector \mathbf{X}' , emanated from point $\mathbf{X} \in \mathcal{R}_{\mathcal{R}}$, will go to the position vector $\hat{\mathbf{x}}' = \hat{\chi}'(\mathbf{X}, \mathbf{X}', t) = \mathbf{f}_p(\mathbf{X}, t)\mathbf{X}'$, emanated from point $\hat{\mathbf{x}} \in \hat{R}_t$. This way, the range $\mathcal{R}'_{\mathcal{R}}(\mathbf{X})$ will be mapped to the range $\hat{R}'_t(\hat{\mathbf{x}}) = \hat{\chi}'(\mathbf{X}, \mathcal{B}')$. For fixed t , we refer to $\hat{\chi}'(\mathbf{X}, \cdot, t)$ as the plastic intermediate configuration of the microscopic continuum at \mathbf{X} . The plastic intermediate configuration for the macroscopic continuum together with that one for the microscopic continuum are called plastic intermediate configuration for the micromorphic continuum. Clearly, \mathbf{F}_p and \mathbf{f}_p , and therefore \mathbf{F}_e and \mathbf{f}_e too, are two-point tensor fields, satisfying polar decompositions

$$\mathbf{F}_e = \mathbf{R}_e \mathbf{U}_e = \mathbf{V}_e \mathbf{R}_e \quad , \quad \mathbf{F}_p = \mathbf{R}_p \mathbf{U}_p = \mathbf{V}_p \mathbf{R}_p \quad , \quad (12.4)$$

$$\mathbf{f}_e = \mathbf{r}_e \mathbf{u}_e = \mathbf{v}_e \mathbf{r}_e \quad , \quad \mathbf{f}_p = \mathbf{r}_p \mathbf{u}_p = \mathbf{v}_p \mathbf{r}_p \quad , \quad (12.5)$$

where $\mathbf{U}_e, \mathbf{U}_p, \mathbf{V}_e, \mathbf{V}_p, \mathbf{u}_e, \mathbf{u}_p, \mathbf{v}_e, \mathbf{v}_p$ are symmetric, positive definite second-order tensors, and $\mathbf{R}_e, \mathbf{R}_p, \mathbf{r}_e, \mathbf{r}_p$ are proper orthogonal second-order tensors (rotations). Aside from the velocity gradient tensors \mathbf{L}, \mathbf{l} introduced in Part I, the plastic deformation rates operating in the plastic intermediate configuration

$$\hat{\mathbf{L}}_p = \dot{\mathbf{F}}_p \mathbf{F}_p^{-1} = \hat{\mathbf{D}}_p + \hat{\mathbf{W}}_p \quad , \quad \hat{\mathbf{D}}_p = \frac{1}{2}(\hat{\mathbf{L}}_p + \hat{\mathbf{L}}_p^T) \quad , \quad \hat{\mathbf{W}}_p = \frac{1}{2}(\hat{\mathbf{L}}_p - \hat{\mathbf{L}}_p^T) \quad , \quad (12.6)$$

$$\hat{\mathbf{l}}_p = \dot{\mathbf{f}}_p \mathbf{f}_p^{-1} = \hat{\mathbf{d}}_p + \hat{\mathbf{w}}_p \quad , \quad \hat{\mathbf{d}}_p = \frac{1}{2}(\hat{\mathbf{l}}_p + \hat{\mathbf{l}}_p^T) \quad , \quad \hat{\mathbf{w}}_p = \frac{1}{2}(\hat{\mathbf{l}}_p - \hat{\mathbf{l}}_p^T) \quad , \quad (12.7)$$

will be useful e.g. for defining strain and stress rates with respect to the plastic intermediate configuration.

As mentioned above, like classical plasticity (cf. [78, 13, 14]), the plastic intermediate configuration may be determined uniquely only within an arbitrary rigid body rotation $\mathbf{Q}_p = \mathbf{Q}_p(t)$. Some transformation rules, which apply to both, rigid body rotations $\mathbf{Q} = \mathbf{Q}(t)$ superposed on the actual configuration, and rigid body rotations $\mathbf{Q}_p = \mathbf{Q}_p(t)$ superposed on the plastic intermediate configuration simultaneously, are given in Sect. 12.4.

12.2.2 Basis systems on \hat{R}_t

Before going any further, it is convenient to introduce some special basis systems. In conjunction with the basis systems $\{\mathbf{g}_i\}$, $\{\mathbf{E}_i\}$, we define

$$\hat{\mathbf{g}}_i := \mathbf{F}_p \mathbf{E}_i \quad , \quad \hat{\mathbf{g}}^i = \mathbf{F}_p^{T-1} \mathbf{E}^i \quad , \quad \hat{\mathbf{g}}^i \cdot \hat{\mathbf{g}}_j = \delta_j^i \quad , \quad (12.8)$$

so that

$$\mathbf{g}_i = \mathbf{F}_e \hat{\mathbf{g}}_i \quad , \quad \mathbf{g}^i = \mathbf{F}_e^{T-1} \hat{\mathbf{g}}^i \quad . \quad (12.9)$$

Additionally, we set

$$\mathbf{F}_p = (\mathbf{F}_p)^i_j \hat{\mathbf{e}}_i \otimes \mathbf{E}^j \quad , \quad (\mathbf{F}_p)^i_j \equiv (\mathbf{F}_p)_{ij} \quad , \quad (12.10)$$

$$\mathbf{F}_p^{-1} = (\mathbf{F}_p^{-1})^i_j \mathbf{E}_i \otimes \hat{\mathbf{e}}^j \quad , \quad (\mathbf{F}_p^{-1})^i_j \equiv (\mathbf{F}_p^{-1})_{ij} \quad . \quad (12.11)$$

It follows that

$$\hat{\mathbf{g}}_i := (\mathbf{F}_p)^j_i \hat{\mathbf{e}}_j \quad , \quad \hat{\mathbf{g}}^i = (\mathbf{F}_p^{-1})^i_j \hat{\mathbf{e}}^j \quad . \quad (12.12)$$

Beyond $\{\hat{\mathbf{g}}_i\}$ and $\{\hat{\mathbf{e}}_i\}$, one may introduce a further basis $\{\hat{\rho}_i\}$ at $\hat{\mathbf{x}}$, by

$$\hat{\rho}_i := \mathbf{f}_p \mathbf{E}_i \quad , \quad \hat{\rho}^i = \mathbf{f}_p^{T-1} \mathbf{E}^i \quad , \quad \hat{\rho}^i \cdot \hat{\rho}_j = \delta_j^i \quad . \quad (12.13)$$

Similar to (12.10), (12.11), we set

$$\mathbf{f}_p = (\mathbf{f}_p)^i_j \hat{\mathbf{e}}_i \otimes \mathbf{E}^j \quad , \quad (\mathbf{f}_p)^i_j \equiv (\mathbf{f}_p)_{ij} \quad , \quad (12.14)$$

$$\mathbf{f}_p^{-1} = (\mathbf{f}_p^{-1})^i_j \mathbf{E}_i \otimes \hat{\mathbf{e}}^j \quad , \quad (\mathbf{f}_p^{-1})^i_j \equiv (\mathbf{f}_p^{-1})_{ij} \quad , \quad (12.15)$$

and hence

$$\hat{\rho}_i = (\mathbf{f}_p)^j_i \hat{\mathbf{e}}_j \quad , \quad \hat{\rho}^i = (\mathbf{f}_p^{-1})^i_j \hat{\mathbf{e}}^j \quad . \quad (12.16)$$

The transformation law between $\{\hat{\mathbf{g}}_i\}$ and $\{\hat{\rho}_i\}$ reads

$$\hat{\mathbf{g}}_i = A^j_i \hat{\rho}_j \quad , \quad \hat{\mathbf{g}}^i = (A^{-1})^i_j \hat{\rho}^j \quad , \quad (12.17)$$

with

$$A^i_j = (\mathbf{f}_p^{-1})^i_r (\mathbf{F}_p)^r_j \quad , \quad (A^{-1})^i_j = (\mathbf{F}_p^{-1})^i_r (\mathbf{f}_p)^r_j \quad , \quad (12.18)$$

$$(A^{-1})^i_r A^r_j = A^i_r (A^{-1})^r_j = \delta_j^i \quad . \quad (12.19)$$

12.2.3 Additive decompositions of the strain tensors

We set in Part I, Sect. 11.5.1, $\mathbf{F}_a = \mathbf{F}_p$, $\mathbf{f}_a = \mathbf{f}_p$, $\beta_a = \hat{\beta}$, $\epsilon_a = \hat{\epsilon}$ and $\mathbf{c}_a = \hat{\mathbf{c}}$, $\varphi_a = \hat{\varphi}$, $\xi_a = \hat{\xi}$, $\zeta_a = \hat{\zeta}$, to get, on the one hand,

$$\hat{\mathbf{c}} = \mathbf{F}_p \mathbf{C} \quad , \quad \hat{\xi} = \mathbf{F}_p^{T-1} \Xi \quad , \quad (12.20)$$

$$\hat{\varphi} = \mathbf{f}_p \Phi \quad , \quad \hat{\zeta} = \mathbf{f}_p^{T-1} \mathbf{Z} \quad , \quad (12.21)$$

and on the other hand

$$\mathbf{c} = \mathbf{F}_e \hat{\mathbf{c}} \quad , \quad \boldsymbol{\xi} = \mathbf{F}_e^{T-1} \hat{\boldsymbol{\xi}} \quad , \quad (12.22)$$

$$\boldsymbol{\varphi} = \mathbf{f}_e \hat{\boldsymbol{\varphi}} \quad , \quad \boldsymbol{\zeta} = \mathbf{f}_e^{T-1} \hat{\boldsymbol{\zeta}} \quad . \quad (12.23)$$

In addition,

$$\hat{\boldsymbol{\beta}} = \mathbf{f}_p^{T-1} \tilde{\boldsymbol{\beta}} \mathbf{f}_p^{-1} \quad , \quad \hat{\boldsymbol{\epsilon}} = \mathbf{f}_p \boldsymbol{\epsilon} \mathbf{F}_p^{-1} \quad . \quad (12.24)$$

These relations suggest additive decompositions of Δ'_s and Δ_s of the form

$$\Delta'_s = \frac{1}{2}(\boldsymbol{\varphi} \cdot \boldsymbol{\varphi} - \boldsymbol{\Phi} \cdot \boldsymbol{\Phi}) = \underbrace{\frac{1}{2}(\boldsymbol{\varphi} \cdot \boldsymbol{\varphi} - \hat{\boldsymbol{\varphi}} \cdot \hat{\boldsymbol{\varphi}})}_{=:(\Delta'_s)_e} + \underbrace{\frac{1}{2}(\hat{\boldsymbol{\varphi}} \cdot \hat{\boldsymbol{\varphi}} - \boldsymbol{\Phi} \cdot \boldsymbol{\Phi})}_{=:(\Delta'_s)_p} = (\Delta'_s)_e + (\Delta'_s)_p \quad (12.25)$$

and

$$\Delta_s = \boldsymbol{\zeta} \cdot \mathbf{c} - \mathbf{Z} \cdot \mathbf{C} = \underbrace{(\boldsymbol{\zeta} \cdot \mathbf{c} - \hat{\boldsymbol{\zeta}} \cdot \hat{\mathbf{c}})}_{=:(\Delta_s)_e} + \underbrace{(\hat{\boldsymbol{\zeta}} \cdot \hat{\mathbf{c}} - \mathbf{Z} \cdot \mathbf{C})}_{=:(\Delta_s)_p} = (\Delta_s)_e + (\Delta_s)_p \quad . \quad (12.26)$$

On requiring from all these scalar valued differences to be form-invariant with respect to the chosen configuration, and by employing similar mathematical manipulations as in Part I, it is straightforward to deduce that (12.25), (12.26) indicate additive decompositions of the strain tensors. For example, with respect to the reference configuration, we have

$$\Delta'_s = \boldsymbol{\Phi} \cdot \tilde{\boldsymbol{\beta}} \boldsymbol{\Phi} \quad , \quad (\Delta'_s)_e = \boldsymbol{\Phi} \cdot \tilde{\boldsymbol{\beta}}_e \boldsymbol{\Phi} \quad , \quad (\Delta'_s)_p = \boldsymbol{\Phi} \cdot \tilde{\boldsymbol{\beta}}_p \boldsymbol{\Phi} \quad , \quad (12.27)$$

$$\tilde{\boldsymbol{\beta}} = \tilde{\boldsymbol{\beta}}_e + \tilde{\boldsymbol{\beta}}_p \quad , \quad (12.28)$$

and

$$\Delta_s = \mathbf{Z} \cdot \tilde{\boldsymbol{\epsilon}} \mathbf{C} \quad , \quad (\Delta_s)_e = \mathbf{Z} \cdot \tilde{\boldsymbol{\epsilon}}_e \mathbf{C} \quad , \quad (\Delta_s)_p = \mathbf{Z} \cdot \tilde{\boldsymbol{\epsilon}}_p \mathbf{C} \quad , \quad (12.29)$$

$$\tilde{\boldsymbol{\epsilon}} = \tilde{\boldsymbol{\epsilon}}_e + \tilde{\boldsymbol{\epsilon}}_p \quad . \quad (12.30)$$

With respect to the plastic intermediate configuration,

$$\Delta'_s = \hat{\boldsymbol{\varphi}} \cdot \hat{\boldsymbol{\beta}} \hat{\boldsymbol{\varphi}} \quad , \quad (\Delta'_s)_e = \hat{\boldsymbol{\varphi}} \cdot \hat{\boldsymbol{\beta}}_e \hat{\boldsymbol{\varphi}} \quad , \quad (\Delta'_s)_p = \hat{\boldsymbol{\varphi}} \cdot \hat{\boldsymbol{\beta}}_p \hat{\boldsymbol{\varphi}} \quad , \quad (12.31)$$

$$\hat{\boldsymbol{\beta}} = \hat{\boldsymbol{\beta}}_e + \hat{\boldsymbol{\beta}}_p \quad , \quad (12.32)$$

$$\hat{\boldsymbol{\beta}} = \mathbf{f}_p^{T-1} \tilde{\boldsymbol{\beta}} \mathbf{f}_p^{-1} \quad , \quad \hat{\boldsymbol{\beta}}_e = \mathbf{f}_p^{T-1} \tilde{\boldsymbol{\beta}}_e \mathbf{f}_p^{-1} \quad , \quad \hat{\boldsymbol{\beta}}_p = \mathbf{f}_p^{T-1} \tilde{\boldsymbol{\beta}}_p \mathbf{f}_p^{-1} \quad , \quad (12.33)$$

and

$$\Delta_s = \hat{\boldsymbol{\zeta}} \cdot \hat{\boldsymbol{\epsilon}} \hat{\mathbf{c}} \quad , \quad (\Delta_s)_e = \hat{\boldsymbol{\zeta}} \cdot \hat{\boldsymbol{\epsilon}}_e \hat{\mathbf{c}} \quad , \quad (\Delta_s)_p = \hat{\boldsymbol{\zeta}} \cdot \hat{\boldsymbol{\epsilon}}_p \hat{\mathbf{c}} \quad , \quad (12.34)$$

$$\hat{\boldsymbol{\epsilon}} = \hat{\boldsymbol{\epsilon}}_e + \hat{\boldsymbol{\epsilon}}_p \quad , \quad (12.35)$$

$$\hat{\boldsymbol{\epsilon}} = \mathbf{f}_p \tilde{\boldsymbol{\epsilon}} \mathbf{F}_p^{-1} \quad , \quad \hat{\boldsymbol{\epsilon}}_e = \mathbf{f}_p \tilde{\boldsymbol{\epsilon}}_e \mathbf{F}_p^{-1} \quad , \quad \hat{\boldsymbol{\epsilon}}_p = \mathbf{f}_p \tilde{\boldsymbol{\epsilon}}_p \mathbf{F}_p^{-1} \quad . \quad (12.36)$$

Further details are given in Sect. 12.6, from which it can be recognized that the tensors $(\tilde{\boldsymbol{\beta}}, \hat{\boldsymbol{\beta}}, \boldsymbol{\beta})$, or $(\tilde{\boldsymbol{\beta}}_e, \hat{\boldsymbol{\beta}}_e, \boldsymbol{\beta}_e)$, or \dots , or $(\tilde{\boldsymbol{\epsilon}}, \hat{\boldsymbol{\epsilon}}, \boldsymbol{\epsilon})$, or $(\tilde{\boldsymbol{\epsilon}}_e, \hat{\boldsymbol{\epsilon}}_e, \boldsymbol{\epsilon}_e)$, or \dots , are, respectively, members of corresponding equivalence classes. Also, like $\tilde{\boldsymbol{\beta}}$, $\tilde{\boldsymbol{\epsilon}}$, the strains $\boldsymbol{\beta}_e$, $\boldsymbol{\beta}_p$, $\boldsymbol{\epsilon}_e$, $\boldsymbol{\epsilon}_p$ are tensors on $\mathcal{R}_{\mathcal{R}}$ (cf. Part I, Sect. 11.5.1), and so forth.

To conclude the discussion about strain tensors, we postulate $(\Delta'_s)_e$, $(\Delta'_s)_p$, $(\Delta_s)_e$ and $(\Delta_s)_p$ to be also form-invariant with respect to the chosen configuration. This allows to define, in a natural way, associated rates for the elastic and plastic parts of the strain tensors. Clearly, the additive decomposition of the strain tensors carries over their associated rates. Sect. 12.6 summarizes formulas of this kind and illustrates how the various strain tensors, and their associated rates, are related to each other.

12.2.4 Additive decomposition of the micromorphic curvature tensors

12.2.4.1 Decomposition of Δ_c

Once more, we set $\mathbf{F}_a = \mathbf{F}_p$, $\mathbf{f}_a = \mathbf{f}_p$, as well as $\mathcal{K}_a = \hat{\mathcal{K}}$, $(\mathbf{g}_a)_k = \hat{\mathbf{g}}_k$, $(\varphi_a)_k = \hat{\varphi}_k$, so that (cf. Part I, Sect. 11.5.1.2)

$$\hat{\varphi}_k = \mathbf{f}_p \Phi_k \quad , \quad \hat{\varphi}^k = \mathbf{f}_p^{T-1} \Phi^k \quad , \quad (12.37)$$

and therefore

$$\varphi_k = \mathbf{f}_e \hat{\varphi}_k \quad , \quad \varphi^k = \mathbf{f}_e^{T-1} \hat{\varphi}^k \quad . \quad (12.38)$$

This suggests additive decomposition of Δ_c (see Part I, Eq. (11.126)) into elastic $(\Delta_c)_e$ and plastic $(\Delta_c)_p$ parts,

$$\Delta_c = \varphi^1 \cdot (\nabla_{\mathcal{R}_t} \varphi_2)[\mathbf{g}_3] - \Phi^1 \cdot (\nabla_{\mathcal{R}_\mathcal{R}} \Phi_2)[\mathbf{E}_3] = (\Delta_c)_e + (\Delta_c)_p \quad (12.39)$$

with

$$(\Delta_c)_e := \varphi^1 \cdot (\nabla_{\mathcal{R}_t} \varphi_2)[\mathbf{g}_3] - \hat{\varphi}^1 \cdot (\nabla_{\hat{R}_t} \hat{\varphi}_2)[\hat{\mathbf{g}}_3] \quad , \quad (12.40)$$

$$(\Delta_c)_p := \hat{\varphi}^1 \cdot (\nabla_{\hat{R}_t} \hat{\varphi}_2)[\hat{\mathbf{g}}_3] - \Phi^1 \cdot (\nabla_{\mathcal{R}_\mathcal{R}} \Phi_2)[\mathbf{E}_3] \quad , \quad (12.41)$$

where, as in Part I, Eqs. (11.127), (11.128),

$$\nabla_{\mathcal{R}_t} \varphi_2 := \text{grad} \varphi_2 = \frac{\partial \varphi_2}{\partial X^k} \otimes \mathbf{g}^k \quad , \quad (12.42)$$

$$\nabla_{\mathcal{R}_\mathcal{R}} \Phi_2 := \text{GRAD} \Phi_2 = \frac{\partial \Phi_2}{\partial X^k} \otimes \mathbf{E}^k \quad . \quad (12.43)$$

Constitutive aspects of the underlying physic of plasticity may be addressed appropriately by using a suitable differential operator $\nabla_{\hat{R}_t}$. In the case of micropolar plasticity, a so-called relative covariant derivative has been proposed by Grammenoudis and Tsakmakis [72] as a possibility. An appropriate definition for relative covariant derivative in micromorphic plasticity has been proposed in Grammenoudis and Tsakmakis [75], which we shall adopt also for the present article. The most important issues of the relative covariant derivative are summarized in the next section.

12.2.4.2 Relative covariant derivative on \hat{R}_t

Let $\hat{\mathbf{b}} = \hat{\mathbf{b}}(\hat{\mathbf{x}}, t)$ be a vector field on \hat{R}_t , $\hat{\mathbf{b}}(\hat{\mathbf{x}}, t) \in T_{\hat{\mathbf{x}}} \hat{R}_t$, with $\hat{\mathbf{b}} = b^m \hat{\rho}_m$. The relative covariant derivative of $\hat{\mathbf{b}}$ is defined (relative to \hat{R}_t) by

$$\hat{\nabla} \hat{\mathbf{b}} := \left(\frac{\partial b^j}{\partial X^i} + \Lambda^j_{il} b^l \right) \hat{\rho}_j \otimes \hat{\mathbf{g}}^i \quad . \quad (12.44)$$

As mentioned in Grammenoudis and Tsakmakis [72], Λ^j_{il} are symbols of connection for the space $\mathcal{R}_\mathcal{R}$ but not for the space \hat{R}_t , and $\hat{\nabla} \hat{\mathbf{b}}$ does not represent a covariant derivative of $\hat{\mathbf{b}}$ relative to \hat{R}_t . Furthermore, Λ^j_{il} defines generally a non-torsion free connection on $\mathcal{R}_\mathcal{R}$. In addition, the space $\mathcal{R}_\mathcal{R}$ may be endowed with a non-Euclidean metric

$$\tilde{G}_{ij} = (\mathbf{f}_p)^k_i \delta_{kl} (\mathbf{f}_p)^l_j = \hat{\rho}_i \cdot \hat{\rho}_j \quad . \quad (12.45)$$

This metric, together with connection Λ_{il}^j renders the space $\mathcal{R}_{\mathcal{R}}$ to be a non-Euclidean and a non-Riemannian one. For the particular choice $\Lambda_{il}^j \equiv (\Lambda_{\mathbf{f}_p})_{il}^j$, with

$$(\Lambda_{\mathbf{f}_p})_{im}^j := (\mathbf{f}_p^{-1})_n^j \frac{\partial (\mathbf{f}_p)_m^n}{\partial X^i} \quad , \quad (12.46)$$

the space $\mathcal{R}_{\mathcal{R}}$ will be flat. In this case, no constitutive laws for $\tilde{\mathcal{K}}_p$ are necessary, provided some evolution laws for \mathbf{f}_p are available.

12.2.4.3 Elastic and plastic parts of the curvature tensor

We turn to the scalar differences in Eqs. (12.40), (12.41), and chose the differential operator $\nabla_{\hat{R}_t}$ to be given by $\hat{\nabla}$ (cf. Eq. (12.44)), so that

$$\nabla_{\hat{R}_t} \hat{\varphi}_2 = \left(\frac{\partial (\hat{\varphi}_2)^j}{\partial X^i} + \Lambda_{im}^j (\hat{\varphi}_2)^m \right) \hat{\rho}_j \otimes \hat{\mathbf{g}}^i \quad , \quad (12.47)$$

where

$$\hat{\varphi}_2 = (\hat{\varphi}_2)^j \hat{\rho}_j \quad , \quad \Phi_2 = (\Phi_2)^j \mathbf{E}_j \quad , \quad (\Phi_2)^j \equiv (\varphi_2)^j \quad . \quad (12.48)$$

It is readily seen that

$$\hat{\varphi}^1 \cdot (\nabla_{\hat{R}_t} \hat{\varphi}_2) [\hat{\mathbf{g}}_3] = \Phi^1 \cdot \mathbf{f}_p^{-1} (\nabla_{\hat{R}_t} \hat{\varphi}_2) \mathbf{F}_p [\mathbf{E}_3] = \Phi^1 \cdot \left\{ \left(\frac{\partial (\Phi_2)^j}{\partial X^i} + \Lambda_{im}^j (\Phi_2)^m \right) \mathbf{E}_j \otimes \mathbf{E}^i \right\} [\mathbf{E}_3] \quad . \quad (12.49)$$

Also, from (12.43),

$$\nabla_{\mathcal{R}_{\mathcal{R}}} \Phi_2 = \left(\frac{\partial (\Phi_2)^j}{\partial X^i} + \lambda_{im}^j (\Phi_2)^m \right) \mathbf{E}_j \otimes \mathbf{E}^i \quad , \quad (12.50)$$

with $\lambda_{im}^j \equiv \lambda_{jim} = 0$ being the symbols, relative to $\{\mathbf{E}_i\}$, of the Levi-Civita connection in $\mathcal{R}_{\mathcal{R}}$. Thus, after inserting into (12.41),

$$(\Delta_c)_p = \Phi^1 \cdot \{ (\Lambda_{im}^j - \lambda_{im}^j) (\Phi_2 \cdot \mathbf{E}^m) \} (\mathbf{E}_j \otimes \mathbf{E}^i) [\mathbf{E}_3] \quad (12.51)$$

or

$$(\Delta_c)_p = \tilde{\mathcal{K}}_p [\Phi^1, \Phi_2, \mathbf{E}_3] \quad (12.52)$$

with

$$\tilde{\mathcal{K}}_p = (\tilde{\mathcal{K}}_p)_{mi}^j \mathbf{E}_j \otimes \mathbf{E}^m \otimes \mathbf{E}^i \quad , \quad (12.53)$$

$$(\tilde{\mathcal{K}}_p)_{mi}^j \equiv (\tilde{\mathcal{K}}_p)_{jmi} = \Lambda_{im}^j - \lambda_{im}^j \quad . \quad (12.54)$$

In addition, it can be seen that

$$(\Delta_c)_e = \tilde{\mathcal{K}}_e [\Phi^1, \Phi_2, \mathbf{E}_3] \quad (12.55)$$

with

$$\tilde{\mathcal{K}} = \tilde{\mathcal{K}}_e + \tilde{\mathcal{K}}_p \quad . \quad (12.56)$$

On requiring from the differences Δ_c , $(\Delta_c)_e$, and $(\Delta_c)_p$ to be form-invariant with respect to the chosen configuration, and by employing similar mathematical manipulations as in Part I, it is straightforward to deduce that, e.g. relative to the plastic intermediate configuration the relations

$$\Delta_c = \hat{\mathcal{K}}[\hat{\varphi}^1, \hat{\varphi}_2, \hat{\mathbf{g}}_3] \quad , \quad \hat{\mathcal{K}} = \mathcal{L}(\mathbf{f}_p, \mathbf{f}_p^{T-1}, \mathbf{F}_p^{T-1})[\tilde{\mathcal{K}}] \quad , \quad (12.57)$$

$$(\Delta_c)_e = \hat{\mathcal{K}}_e[\hat{\varphi}^1, \hat{\varphi}_2, \hat{\mathbf{g}}_3] \quad , \quad \hat{\mathcal{K}}_e = \mathcal{L}(\mathbf{f}_p, \mathbf{f}_p^{T-1}, \mathbf{F}_p^{T-1})[\tilde{\mathcal{K}}_e] \quad , \quad (12.58)$$

$$(\Delta_c)_p = \hat{\mathcal{K}}_p[\hat{\varphi}^1, \hat{\varphi}_2, \hat{\mathbf{g}}_3] \quad , \quad \hat{\mathcal{K}}_p = \mathcal{L}(\mathbf{f}_p, \mathbf{f}_p^{T-1}, \mathbf{F}_p^{T-1})[\tilde{\mathcal{K}}_p] \quad , \quad (12.59)$$

$$\hat{\mathcal{K}} = \hat{\mathcal{K}}_e + \hat{\mathcal{K}}_p \quad (12.60)$$

apply. Further relations are given in Sect. 12.6. Obviously, tensors $\tilde{\mathcal{K}}$, $\hat{\mathcal{K}}$, \mathcal{K} , ... are members of an equivalence class.

Postulating also $(\Delta_c)_e$, $(\Delta_c)_p$, ... to be form-invariant with respect to the chosen configuration, associated rates for the elastic and plastic parts of the micromorphic curvature tensors can be defined in a natural way. Clearly, the additive decomposition of the curvature tensors carries over their associated rates. Sect. 12.6 summarizes formulas of this kind and illustrates how the various micromorphic curvature tensors, and their associated rates, are related to each other.

Remark

As indicated in conjunction with Eq. (12.46), there are two possibilities for the curvature tensor $\tilde{\mathcal{K}}_p$.

1. Λ_{im}^j , and therefore $\tilde{\mathcal{K}}_p$ too, are not subject to some compatibility conditions, so that the Riemannian curvature tensor is non-vanishing. Then, separate constitutive laws are needed for plastic strain variables and for $\tilde{\mathcal{K}}_p$.
2. Λ_{im}^j in Eq. (12.54) is assumed to be equal to $(\Lambda_{\mathbf{f}_p})_{im}^j$ in Eq. (12.46). Since the right-hand side of (12.46) is related to the gradient of \mathbf{f}_p , it is not necessary to postulate constitutive relations governing the response of $\tilde{\mathcal{K}}_p$, provided some evolution equations for \mathbf{f}_p are available.

In the present article we are concerned with the first possibility only. (The other case will be discussed elsewhere.)

12.2.5 Stress tensors and their associated rates

It has been shown in Part I how dual stress tensors and associated rates may be introduced with the help of the stress powers w' , w , and w_c . By setting $\mathbf{f}_a = \mathbf{f}_p$, $\mathbf{F}_a = \mathbf{F}_p$ (see Part I, Sect. 11.5.3), we obtain with respect to the plastic intermediate configuration \hat{R}_t ,

$$w' = \hat{\boldsymbol{\sigma}} \cdot \hat{\boldsymbol{\beta}} \quad , \quad w = \hat{\mathbf{S}} \cdot \hat{\boldsymbol{\epsilon}} \quad , \quad w_c = \hat{\mathbf{S}} \cdot \hat{\mathcal{K}} \quad , \quad (12.61)$$

where

$$\hat{\boldsymbol{\sigma}} := \mathbf{f}_p \tilde{\boldsymbol{\sigma}} \mathbf{f}_p^T \quad , \quad \hat{\mathbf{S}} := \mathbf{f}_p^{T-1} \tilde{\mathbf{S}} \mathbf{F}_p^T \quad , \quad \hat{\mathcal{K}} := \mathbf{f}_p^{T-1} \tilde{\mathcal{K}} \mathbf{F}_p^T \quad . \quad (12.62)$$

It is of interest to remark that the stress tensors $\tilde{\boldsymbol{\sigma}}$, $\hat{\boldsymbol{\sigma}}$, $\boldsymbol{\sigma}$, or $\tilde{\mathbf{S}}$, $\hat{\mathbf{S}}$, \mathbf{S} , or $\tilde{\mathcal{K}}$, $\hat{\mathcal{K}}$, \mathcal{K} are members of corresponding equivalence classes. The associated rates of the stress tensors in (12.62) read

$$\overset{\nabla}{\hat{\boldsymbol{\sigma}}} = \dot{\hat{\boldsymbol{\sigma}}} - \hat{\mathbf{l}}_p \hat{\boldsymbol{\sigma}} - \hat{\boldsymbol{\sigma}} \hat{\mathbf{l}}_p^T \quad , \quad (12.63)$$

$$\overset{\nabla}{\hat{\mathbf{S}}} = \dot{\hat{\mathbf{S}}} + \hat{\mathbf{I}}_p^T \hat{\mathbf{S}} - \hat{\mathbf{S}} \hat{\mathbf{L}}_p^T \quad , \quad (12.64)$$

$$\overset{\nabla}{\hat{\mathbf{S}}} = \dot{\hat{\mathbf{S}}} + \hat{\mathbf{I}}_p \hat{\mathbf{S}} - \hat{\mathbf{S}} \diamond \hat{\mathbf{I}}_p^T - \hat{\mathbf{S}} \hat{\mathbf{L}}_p \quad . \quad (12.65)$$

Although no stress and double stress rates are needed for the purpose of the present paper, for reasons of completeness some results are given in Sect. 12.6.

12.3 Thermodynamical framework for micromorphic plasticity

In the following all components are given with respect to the bases $\{\mathbf{E}_i\}$, $\{\hat{\mathbf{e}}_i\}$ or $\{\mathbf{e}_i\}$, so that no distinction between lower and upper indices is made.

We assume isothermal deformations with uniform temperature distribution. Then, the Clausius-Duhem inequality for micromorphic materials, with respect to the actual configuration, takes the form (cf. Eringen [46, p.50])

$$\mathbf{S} \cdot (\mathbf{L} - \mathbf{1}) + \boldsymbol{\sigma} \cdot \mathbf{d} + \mathcal{S} \cdot \text{grad} \mathbf{l} - \varrho_{\mathcal{R}} \dot{\Psi} \equiv \mathbf{S} \cdot \overset{\Delta}{\hat{\boldsymbol{\epsilon}}} + \boldsymbol{\sigma} \cdot \overset{\Delta}{\hat{\boldsymbol{\beta}}} + \mathcal{S} \cdot \overset{\Delta}{\hat{\mathcal{K}}} - \varrho_{\mathcal{R}} \dot{\Psi} \geq 0 \quad , \quad (12.66)$$

where Ψ is the specific (per unit mass of the macroscopic continuum) free energy of the micromorphic material. As usually in classical plasticity, we assume the decomposition

$$\Psi(t) = \Psi_e(t) + \Psi_p(t) \quad . \quad (12.67)$$

Hence, inequality (12.66) is equivalent to

$$\mathbf{S} \cdot \overset{\Delta}{\hat{\boldsymbol{\epsilon}}} + \boldsymbol{\sigma} \cdot \overset{\Delta}{\hat{\boldsymbol{\beta}}} + \mathcal{S} \cdot \overset{\Delta}{\hat{\mathcal{K}}} - \varrho_{\mathcal{R}} \dot{\Psi}_e - \varrho_{\mathcal{R}} \dot{\Psi}_p \geq 0 \quad , \quad (12.68)$$

or, with respect to the plastic intermediate configuration,

$$\hat{\mathbf{S}} \cdot \overset{\Delta}{\hat{\boldsymbol{\epsilon}}} + \hat{\boldsymbol{\sigma}} \cdot \overset{\Delta}{\hat{\boldsymbol{\beta}}} + \hat{\mathcal{S}} \cdot \overset{\Delta}{\hat{\mathcal{K}}} - \varrho_{\mathcal{R}} \dot{\Psi}_e - \varrho_{\mathcal{R}} \dot{\Psi}_p \geq 0 \quad . \quad (12.69)$$

12.3.1 Elasticity laws – dissipation inequality

In analogy to the case of pure elasticity (cf. Part I, Sect. 11.3.4), we suppose Ψ_e to have the form

$$\Psi_e = \hat{\Psi}_e(\hat{\boldsymbol{\epsilon}}_e, \hat{\boldsymbol{\beta}}_e, \hat{\mathcal{K}}_e) \quad . \quad (12.70)$$

Evidently, Ψ_e must be invariant under arbitrary rigid body rotations \mathbf{Q}_p superposed on the plastic intermediate configuration, which implies (cf. Sect. 12.4),

$$\Psi_e = \hat{\Psi}_e(\mathbf{Q}_p \hat{\boldsymbol{\epsilon}}_e \mathbf{Q}_p^T, \mathbf{Q}_p \hat{\boldsymbol{\beta}}_e \mathbf{Q}_p^T, \mathcal{L}(\mathbf{Q}_p, \mathbf{Q}_p, \mathbf{Q}_p)[\hat{\mathcal{K}}_e]) \quad . \quad (12.71)$$

But, this is exactly the condition for $\hat{\Psi}_e$ to be an isotropic tensor function. Consequently, Ψ_e must be a function of scalar invariants of $\hat{\boldsymbol{\epsilon}}_e$, $\hat{\boldsymbol{\beta}}_e$, $\hat{\mathcal{K}}_e$, as e.g. $(\hat{\boldsymbol{\epsilon}}_e)_{ii}$, $(\hat{\boldsymbol{\beta}}_e)_{ii}$, $(\hat{\boldsymbol{\beta}}_e)_{ij}(\hat{\boldsymbol{\epsilon}}_e + \hat{\boldsymbol{\epsilon}}_e^T)_{ij}$, $(\hat{\mathcal{K}}_e)_{ijj}(\hat{\mathcal{K}}_e)_{imm}$, \dots . These can be expressed in terms of $\tilde{\boldsymbol{\epsilon}}_e$, $\tilde{\boldsymbol{\epsilon}}_p$, $\tilde{\boldsymbol{\beta}}_e$, $\tilde{\boldsymbol{\beta}}_p$, $\tilde{\mathcal{K}}_e$,

$$(\hat{\boldsymbol{\epsilon}}_e)_{ii} = (\tilde{\boldsymbol{\epsilon}}_e)_{jm} ((\tilde{\boldsymbol{\epsilon}}_p + \mathbf{1})^{-1})_{mj} \quad , \quad (12.72)$$

$$(\hat{\beta}_e)_{ii} = (\tilde{\beta}_e)_{jm} \left((2\tilde{\beta}_p + \mathbf{1})^{-1} \right)_{mj} , \quad (12.73)$$

$$\begin{aligned} (\hat{\beta}_e)_{ij}(\hat{\epsilon}_e + \hat{\epsilon}_e^T)_{ij} &= (\tilde{\beta}_e)_{ij} \left((2\tilde{\beta}_p + \mathbf{1})^{-1} \right)_{im} \left((\tilde{\epsilon}_p + \mathbf{1})^{T-1} \right)_{mk} (\tilde{\epsilon}_e)_{jk} \\ &\quad + (\tilde{\beta}_e)_{ij}(\tilde{\epsilon}_e)_{im} \left((\tilde{\epsilon}_p + \mathbf{1})^{-1} \right)_{mk} \left((2\tilde{\beta}_p + \mathbf{1})^{-1} \right)_{kj} , \end{aligned} \quad (12.74)$$

$$\begin{aligned} (\hat{\mathcal{K}}_e)_{ijj}(\hat{\mathcal{K}}_e)_{ill} &= (2\tilde{\beta}_p + \mathbf{1})_{mp} \left((2\tilde{\beta}_p + \mathbf{1})^{-1} \right)_{nl} \left((\tilde{\epsilon}_p + \mathbf{1})^{T-1} \right)_{ls} \\ &\quad \left((2\tilde{\beta}_p + \mathbf{1})^{-1} \right)_{qk} \left((\tilde{\epsilon}_p + \mathbf{1})^{T-1} \right)_{kr} (\tilde{\mathcal{K}}_e)_{mns} (\tilde{\mathcal{K}}_e)_{pqr} , \end{aligned} \quad (12.75)$$

⋮

Therefore, Ψ_e can be represented also as a function of $\tilde{\epsilon}$, $\tilde{\beta}$, $\tilde{\mathcal{K}}$, $\tilde{\epsilon}_p$, $\tilde{\beta}_p$, $\tilde{\mathcal{K}}_p$,

$$\Psi_e = \tilde{\Psi}_e(\tilde{\epsilon}, \tilde{\beta}, \tilde{\mathcal{K}}, \tilde{\epsilon}_p, \tilde{\beta}_p, \tilde{\mathcal{K}}_p) . \quad (12.76)$$

In order to exploit inequality (12.69) we need $\dot{\Psi}_e$. After some lengthy mathematical manipulation, we deduce from (12.70)

$$\begin{aligned} \dot{\Psi}_e &= \frac{\partial \hat{\Psi}_e}{\partial \hat{\epsilon}_e} \cdot \hat{\dot{\epsilon}}_e + \frac{\partial \hat{\Psi}_e}{\partial \hat{\beta}_e} \cdot \hat{\dot{\beta}}_e + \frac{\partial \hat{\Psi}_e}{\partial \hat{\mathcal{K}}_e} \cdot \hat{\dot{\mathcal{K}}}_e - \left\{ \hat{\epsilon}_e^T \frac{\partial \hat{\Psi}_e}{\partial \hat{\epsilon}_e} + \frac{1}{\varrho \mathcal{R}} \hat{\eta} \right\} \cdot \hat{\dot{\epsilon}}_p \\ &\quad - \left\{ 2\hat{\beta}_e \frac{\partial \hat{\Psi}_e}{\partial \hat{\beta}_e} + \frac{1}{\varrho \mathcal{R}} \hat{\Lambda} \right\}_S \cdot \hat{\dot{\beta}}_p - \left\{ 2\hat{\beta}_e \frac{\partial \hat{\Psi}_e}{\partial \hat{\beta}_e} + \frac{1}{\varrho \mathcal{R}} \hat{\Lambda} \right\}_A \cdot \hat{\dot{\mathbf{w}}}_p , \end{aligned} \quad (12.77)$$

where

$$\frac{1}{\varrho \mathcal{R}} \hat{\Lambda} := \frac{1}{\varrho \mathcal{R}} \hat{\eta} - \frac{1}{\varrho \mathcal{R}} \hat{\chi} + \hat{\epsilon}_e^T \frac{\partial \hat{\Psi}_e}{\partial \hat{\epsilon}_e} - \frac{\partial \hat{\Psi}_e}{\partial \hat{\epsilon}_e} \hat{\epsilon}_e^T , \quad (12.78)$$

$\{\cdot\}_S$, $\{\cdot\}_A$ are the symmetric and skew-symmetric parts of $\{\cdot\}$, respectively, and $\hat{\eta}$, $\hat{\chi}$ are given by

$$\frac{1}{\varrho \mathcal{R}} (\hat{\eta})_{ml} := \frac{\partial \hat{\Psi}_e}{\partial (\hat{\mathcal{K}}_e)_{rnl}} (\hat{\mathcal{K}}_e)_{rnm} , \quad (12.79)$$

$$\frac{1}{\varrho \mathcal{R}} (\hat{\chi})_{ml} := \frac{\partial \hat{\Psi}_e}{\partial (\hat{\mathcal{K}}_e)_{mnr}} (\hat{\mathcal{K}}_e)_{lnr} - \frac{\partial \hat{\Psi}_e}{\partial (\hat{\mathcal{K}}_e)_{nlr}} (\hat{\mathcal{K}}_e)_{nmr} . \quad (12.80)$$

Eq. (12.77) may be rewritten as

$$\begin{aligned} \dot{\Psi}_e &= \frac{\partial \hat{\Psi}_e}{\partial \hat{\epsilon}_e} \cdot \hat{\dot{\epsilon}} + \frac{\partial \hat{\Psi}_e}{\partial \hat{\beta}_e} \cdot \hat{\dot{\beta}} + \frac{\partial \hat{\Psi}_e}{\partial \hat{\mathcal{K}}_e} \cdot \hat{\dot{\mathcal{K}}} - \left\{ (1 + \hat{\epsilon}_e^T) \frac{\partial \hat{\Psi}_e}{\partial \hat{\epsilon}_e} + \frac{1}{\varrho \mathcal{R}} \hat{\eta} \right\} \cdot \hat{\dot{\epsilon}}_p \\ &\quad - \left\{ (1 + 2\hat{\beta}_e) \frac{\partial \hat{\Psi}_e}{\partial \hat{\beta}_e} + \frac{1}{\varrho \mathcal{R}} \hat{\Lambda} \right\}_S \cdot \hat{\dot{\beta}}_p - \left\{ 2\hat{\beta}_e \frac{\partial \hat{\Psi}_e}{\partial \hat{\beta}_e} + \frac{1}{\varrho \mathcal{R}} \hat{\Lambda} \right\}_A \cdot \hat{\dot{\mathbf{w}}}_p - \frac{\partial \hat{\Psi}_e}{\partial \hat{\mathcal{K}}_e} \cdot \hat{\dot{\mathcal{K}}}_p . \end{aligned} \quad (12.81)$$

Now, we shall show that $\left\{ 2\hat{\beta}_e \frac{\partial \hat{\Psi}_e}{\partial \hat{\beta}_e} + \frac{1}{\varrho \mathcal{R}} \hat{\Lambda} \right\}_A \equiv 0$. To this end, we take the material time derivative of (12.76),

$$\dot{\Psi}_e = \frac{\partial \tilde{\Psi}_e}{\partial \tilde{\epsilon}} \cdot \dot{\tilde{\epsilon}} + \frac{\partial \tilde{\Psi}_e}{\partial \tilde{\beta}} \cdot \dot{\tilde{\beta}} + \frac{\partial \tilde{\Psi}_e}{\partial \tilde{\mathcal{K}}} \cdot \dot{\tilde{\mathcal{K}}} + \frac{\partial \tilde{\Psi}_e}{\partial \tilde{\epsilon}_p} \cdot \dot{\tilde{\epsilon}}_p + \frac{\partial \tilde{\Psi}_e}{\partial \tilde{\beta}_p} \cdot \dot{\tilde{\beta}}_p + \frac{\partial \tilde{\Psi}_e}{\partial \tilde{\mathcal{K}}_p} \cdot \dot{\tilde{\mathcal{K}}}_p$$

$$\begin{aligned}
 &= \mathbf{f}_p^{T-1} \frac{\partial \tilde{\Psi}_e}{\partial \tilde{\boldsymbol{\epsilon}}} \mathbf{F}_p^T \cdot \hat{\boldsymbol{\epsilon}} + \mathbf{f}_p \frac{\partial \tilde{\Psi}_e}{\partial \tilde{\boldsymbol{\beta}}} \mathbf{f}_p^T \cdot \hat{\boldsymbol{\beta}} + \mathcal{L}(\mathbf{f}_p^{T-1}, \mathbf{f}_p, \mathbf{F}_p) \left[\frac{\partial \tilde{\Psi}_e}{\partial \tilde{\mathcal{K}}} \right] \cdot \hat{\mathcal{K}} \\
 &\quad + \mathbf{f}_p^{T-1} \frac{\partial \tilde{\Psi}_e}{\partial \tilde{\boldsymbol{\epsilon}}_p} \mathbf{F}_p^T \cdot \hat{\boldsymbol{\epsilon}}_p + \mathbf{f}_p \frac{\partial \tilde{\Psi}_e}{\partial \tilde{\boldsymbol{\beta}}_p} \mathbf{f}_p^T \cdot \hat{\boldsymbol{\beta}}_p + \mathcal{L}(\mathbf{f}_p^{T-1}, \mathbf{f}_p, \mathbf{F}_p) \left[\frac{\partial \tilde{\Psi}_e}{\partial \tilde{\mathcal{K}}_p} \right] \cdot \hat{\mathcal{K}}_p \quad .
 \end{aligned} \tag{12.82}$$

On comparing (12.81) with (12.82),

$$\frac{\partial \hat{\Psi}_e}{\partial \hat{\boldsymbol{\epsilon}}_e} = \mathbf{f}_p^{T-1} \frac{\partial \tilde{\Psi}_e}{\partial \tilde{\boldsymbol{\epsilon}}} \mathbf{F}_p^T \quad , \tag{12.83}$$

$$\frac{\partial \hat{\Psi}_e}{\partial \hat{\boldsymbol{\beta}}_e} = \mathbf{f}_p \frac{\partial \tilde{\Psi}_e}{\partial \tilde{\boldsymbol{\beta}}} \mathbf{f}_p^T \quad , \tag{12.84}$$

$$\frac{\partial \hat{\Psi}_e}{\partial \hat{\mathcal{K}}_e} = \mathcal{L}(\mathbf{f}_p^{T-1}, \mathbf{f}_p, \mathbf{F}_p) \left[\frac{\partial \tilde{\Psi}_e}{\partial \tilde{\mathcal{K}}} \right] \quad , \tag{12.85}$$

$$- \left\{ (\mathbf{1} + \hat{\boldsymbol{\epsilon}}_e^T) \frac{\partial \hat{\Psi}_e}{\partial \hat{\boldsymbol{\epsilon}}_e} + \frac{1}{\varrho_{\mathcal{R}}} \hat{\boldsymbol{\eta}} \right\} = \mathbf{f}_p^{T-1} \frac{\partial \tilde{\Psi}_e}{\partial \tilde{\boldsymbol{\epsilon}}_p} \mathbf{F}_p^T \quad , \tag{12.86}$$

$$- \left\{ (\mathbf{1} + 2\hat{\boldsymbol{\beta}}_e) \frac{\partial \hat{\Psi}_e}{\partial \hat{\boldsymbol{\beta}}_e} + \frac{1}{\varrho_{\mathcal{R}}} \hat{\boldsymbol{\Lambda}} \right\}_S = \mathbf{f}_p \frac{\partial \tilde{\Psi}_e}{\partial \tilde{\boldsymbol{\beta}}_p} \mathbf{f}_p^T \quad , \tag{12.87}$$

$$- \frac{\partial \hat{\Psi}_e}{\partial \hat{\mathcal{K}}_e} = \mathcal{L}(\mathbf{f}_p^{T-1}, \mathbf{f}_p, \mathbf{F}_p) \left[\frac{\partial \tilde{\Psi}_e}{\partial \tilde{\mathcal{K}}_p} \right] \quad , \tag{12.88}$$

$$\left\{ 2\hat{\boldsymbol{\beta}}_e \frac{\partial \hat{\Psi}_e}{\partial \hat{\boldsymbol{\beta}}_e} + \frac{1}{\varrho_{\mathcal{R}}} \hat{\boldsymbol{\Lambda}} \right\}_A = 0 \quad , \tag{12.89}$$

which proves the assertion.

Substituting (12.77) into (12.69),

$$\begin{aligned}
 &\left(\hat{\mathbf{S}} - \varrho_{\mathcal{R}} \frac{\partial \hat{\Psi}_e}{\partial \hat{\boldsymbol{\epsilon}}_e} \right) \cdot \hat{\boldsymbol{\epsilon}} + \left\{ \varrho_{\mathcal{R}} (\mathbf{1} + \hat{\boldsymbol{\epsilon}}_e^T) \frac{\partial \hat{\Psi}_e}{\partial \hat{\boldsymbol{\epsilon}}_e} + \hat{\boldsymbol{\eta}} \right\} \cdot \hat{\boldsymbol{\epsilon}}_p \\
 &+ \left(\hat{\boldsymbol{\sigma}} - \varrho_{\mathcal{R}} \frac{\partial \hat{\Psi}_e}{\partial \hat{\boldsymbol{\beta}}_e} \right) \cdot \hat{\boldsymbol{\beta}} + \left\{ \varrho_{\mathcal{R}} (\mathbf{1} + 2\hat{\boldsymbol{\beta}}_e) \frac{\partial \hat{\Psi}_e}{\partial \hat{\boldsymbol{\beta}}_e} + \hat{\boldsymbol{\Lambda}} \right\}_S \cdot \hat{\boldsymbol{\beta}}_p \\
 &+ \left(\hat{\mathcal{S}} - \varrho_{\mathcal{R}} \frac{\partial \hat{\Psi}_e}{\partial \hat{\mathcal{K}}_e} \right) \cdot \hat{\mathcal{K}} + \varrho_{\mathcal{R}} \frac{\partial \hat{\Psi}_e}{\partial \hat{\mathcal{K}}_e} \cdot \hat{\mathcal{K}}_p - \varrho_{\mathcal{R}} \dot{\Psi}_p \geq 0 \quad ,
 \end{aligned} \tag{12.90}$$

which must be satisfied for all $\hat{\boldsymbol{\epsilon}}_e$, $\hat{\boldsymbol{\beta}}_e$ and $\hat{\mathcal{K}}_e$.

We assume that $\hat{\mathbf{S}}$, $\hat{\boldsymbol{\sigma}}$ and $\hat{\mathcal{S}}$ are functions of $\hat{\boldsymbol{\epsilon}}_e$, $\hat{\boldsymbol{\beta}}_e$, $\hat{\mathcal{K}}_e$,

$$\hat{\mathbf{S}} = \hat{\mathbf{S}}(\hat{\boldsymbol{\epsilon}}_e, \hat{\boldsymbol{\beta}}_e, \hat{\mathcal{K}}_e) \quad , \quad \hat{\boldsymbol{\sigma}} = \hat{\boldsymbol{\sigma}}(\hat{\boldsymbol{\epsilon}}_e, \hat{\boldsymbol{\beta}}_e, \hat{\mathcal{K}}_e) \quad , \quad \hat{\mathcal{S}} = \hat{\mathcal{S}}(\hat{\boldsymbol{\epsilon}}_e, \hat{\boldsymbol{\beta}}_e, \hat{\mathcal{K}}_e) \quad , \tag{12.91}$$

and that Ψ_p depends on internal state variables describing the hardening response of the micromorphic material. For the case of rate-dependent plasticity, referred to as viscoplasticity, we assume the

evolution of the internal state variables to depend also on state variables (but not on their rates). That is, we suppose $\overset{\Delta}{\hat{\boldsymbol{\epsilon}}}_p$, $\overset{\Delta}{\hat{\boldsymbol{\beta}}}_p$, $\overset{\Delta}{\hat{\boldsymbol{\mathcal{K}}}}_p$ and $\dot{\Psi}_p$ to be functions of state variables only. Thus, using similar arguments as in Coleman and Gurtin [28], we may conclude that the relations

$$\hat{\mathbf{S}} = \varrho_{\mathcal{R}} \frac{\partial \hat{\Psi}_e}{\partial \hat{\boldsymbol{\epsilon}}_e} = \varrho_{\mathcal{R}} \mathbf{f}_p^{T-1} \frac{\partial \tilde{\Psi}_e}{\partial \tilde{\boldsymbol{\epsilon}}} \mathbf{F}_p^T \quad , \quad (12.92)$$

$$\hat{\boldsymbol{\sigma}} = \varrho_{\mathcal{R}} \frac{\partial \hat{\Psi}_e}{\partial \hat{\boldsymbol{\beta}}_e} = \varrho_{\mathcal{R}} \mathbf{f}_p \frac{\partial \tilde{\Psi}_e}{\partial \tilde{\boldsymbol{\beta}}} \mathbf{f}_p^T \quad , \quad (12.93)$$

$$\hat{\mathbf{S}} = \varrho_{\mathcal{R}} \frac{\partial \hat{\Psi}_e}{\partial \hat{\boldsymbol{\mathcal{K}}}_e} = \varrho_{\mathcal{R}} \mathcal{L}(\mathbf{f}_p^{T-1}, \mathbf{f}_p, \mathbf{F}_p) \left[\frac{\partial \tilde{\Psi}_e}{\partial \tilde{\boldsymbol{\mathcal{K}}} } \right] \quad , \quad (12.94)$$

$$\mathcal{D} := \left\{ \varrho_{\mathcal{R}} (\mathbf{1} + \hat{\boldsymbol{\epsilon}}_e^T) \frac{\partial \hat{\Psi}_e}{\partial \hat{\boldsymbol{\epsilon}}_e} + \hat{\boldsymbol{\eta}} \right\} \cdot \overset{\Delta}{\hat{\boldsymbol{\epsilon}}}_p + \left\{ \varrho_{\mathcal{R}} (\mathbf{1} + 2\hat{\boldsymbol{\beta}}_e) \frac{\partial \hat{\Psi}_e}{\partial \hat{\boldsymbol{\beta}}_e} + \hat{\boldsymbol{\Lambda}} \right\}_S \cdot \overset{\Delta}{\hat{\boldsymbol{\beta}}}_p + \varrho_{\mathcal{R}} \frac{\partial \hat{\Psi}_e}{\partial \hat{\boldsymbol{\mathcal{K}}}_e} \cdot \overset{\Delta}{\hat{\boldsymbol{\mathcal{K}}}}_p - \varrho_{\mathcal{R}} \dot{\Psi}_p \geq 0 \quad (12.95)$$

are necessary and sufficient conditions in order for inequality (12.90) to be valid in every admissible process. We call inequality (12.95) the internal dissipation inequality.

For rate-independent plasticity, often called plasticity, we define the evolution of internal state variables to depend on the state variables and the rates of the strain and micromorphic curvature tensors. Consequently, relations (12.92)–(12.95) are necessary and sufficient for (12.90) to be valid in every purely elastic admissible process, for which, by definition, $\overset{\Delta}{\hat{\boldsymbol{\epsilon}}}_p$, $\overset{\Delta}{\hat{\boldsymbol{\beta}}}_p$, $\overset{\Delta}{\hat{\boldsymbol{\mathcal{K}}}}_p$ vanish. However, we assume (12.92)–(12.95) to apply also along loading paths where inelastic flow is involved, so that for (rate-independent) plasticity these relations are generally only sufficient conditions for (12.90).

It is convenient to introduce the stress tensors

$$\hat{\mathbf{P}} := (\mathbf{1} + \hat{\boldsymbol{\epsilon}}_e^T) \hat{\mathbf{S}} + \hat{\boldsymbol{\eta}} \quad , \quad (12.96)$$

$$\hat{\boldsymbol{\Pi}} := \left\{ (\mathbf{1} + 2\hat{\boldsymbol{\beta}}_e) \hat{\boldsymbol{\sigma}} + \hat{\boldsymbol{\Lambda}} \right\}_S \quad , \quad (12.97)$$

where $\hat{\boldsymbol{\Lambda}}$ reads, in terms of $\hat{\mathbf{S}}$,

$$\hat{\boldsymbol{\Lambda}} = \hat{\boldsymbol{\eta}} - \hat{\boldsymbol{\chi}} + \hat{\boldsymbol{\epsilon}}_e^T \hat{\mathbf{S}} - \hat{\mathbf{S}} \hat{\boldsymbol{\epsilon}}_e^T \quad , \quad (12.98)$$

and $\hat{\boldsymbol{\chi}}$, $\hat{\boldsymbol{\eta}}$ are given by (12.79), (12.80). Then, inequality (12.95) becomes

$$\mathcal{D} = \hat{\mathbf{P}} \cdot \overset{\Delta}{\hat{\boldsymbol{\epsilon}}}_p + \hat{\boldsymbol{\Pi}} \cdot \overset{\Delta}{\hat{\boldsymbol{\beta}}}_p + \hat{\mathbf{S}} \cdot \overset{\Delta}{\hat{\boldsymbol{\mathcal{K}}}}_p - \varrho_{\mathcal{R}} \dot{\Psi}_p \geq 0 \quad . \quad (12.99)$$

It is worthwhile mentioning that the plastic stress power is represented by means of the stress tensors $\hat{\mathbf{P}}$, $\hat{\boldsymbol{\Pi}}$, and $\hat{\mathbf{S}}$, i.e. these stress tensors play a similar role as the so-called Mandel stress tensor in classical plasticity (see e.g. [112, 157]). Therefore, it is meaningful to refer to these stress tensors also as Mandel stress tensors of the micromorphic material. Note in passing that Mandel stress tensors for plastically deformable micropolar materials have been introduced in Grammenoudis and Tsakmakis [67].

12.3.2 Postulate of Il'iushin – flow rule for plasticity

The postulate of Il'iushin has been investigated in the framework of classical rate-independent plasticity, among others, by [85, 86, 32, 15, 112, 108, 114, 58, 148] as well as [157, 159, 160]. An appropriate generalization of the postulate for micropolar plasticity has been worked out in Grammenoudis and Tsakmakis [67]. Here, we shall adopt the validity of this postulate, in an appropriate fashion for micromorphic (rate-independent) plasticity. Flow rules for $\hat{\epsilon}_p$, $\hat{\beta}_p$, and $\hat{\mathcal{K}}_p$ will then be derived as sufficient conditions for the postulate.

Let

$$f(t) = \hat{f}(\hat{\mathbf{P}}, \hat{\mathbf{\Pi}}, \hat{\mathbf{S}}, \hat{\mathbf{h}}) \quad (12.100)$$

be a yield function with respect to the space of the stress tensors $\hat{\mathbf{P}}$, $\hat{\mathbf{\Pi}}$, $\hat{\mathbf{S}}$, with $\hat{\mathbf{h}}$ being a set of internal state variables \hat{h}_i , $1 \leq i \leq M$. The latter are scalars or components of tensors capturing hardening properties. It is assumed that (12.100) may be recast in a "strain-curvature space" formulation with respect to the reference configuration in the form

$$f(t) = \tilde{g}(\tilde{\epsilon}, \tilde{\beta}, \tilde{\mathcal{K}}, \tilde{\epsilon}_p, \tilde{\beta}_p, \tilde{\mathcal{K}}_p, \tilde{\mathbf{q}}) \quad , \quad (12.101)$$

where $\tilde{\mathbf{q}}$ denotes a set of internal state variables \tilde{q}_j , $1 \leq j \leq N$, associated in some way with the hardening variables \hat{h}_i .

The equation

$$f(t) = \hat{f}(\hat{\mathbf{P}}, \hat{\mathbf{\Pi}}, \hat{\mathbf{S}}, \hat{\mathbf{h}}) = \tilde{g}(\tilde{\epsilon}, \tilde{\beta}, \tilde{\mathcal{K}}, \tilde{\epsilon}_p, \tilde{\beta}_p, \tilde{\mathcal{K}}_p, \tilde{\mathbf{q}}) = 0 \quad (12.102)$$

is called yield condition. For fixed values of $\hat{\mathbf{h}}$, it describes a so-called yield surface in the space of the stress tensors $\hat{\mathbf{P}}$, $\hat{\mathbf{\Pi}}$, and $\hat{\mathbf{S}}$. For fixed values of $\tilde{\epsilon}_p$, $\tilde{\beta}_p$, $\tilde{\mathcal{K}}_p$, $\tilde{\mathbf{q}}$ it describes a yield surface in the space of the strain tensors $\tilde{\epsilon}$, $\tilde{\beta}$ and micromorphic curvature tensors $\tilde{\mathcal{K}}$. For simplicity, the yield surfaces are assumed to be smooth.

Loading processes involving plastic flow may be described by employing, instead of time t , a scalar parameter s denoting a plastic arc length. It is postulated that for $s = \text{const.}$ all internal state variables stay constant as well. Furthermore, it is convenient to introduce a so-called loading factor $L(t)$ (cf. [156]),

$$L := [\dot{f}]_{s=\text{const.}} \quad . \quad (12.103)$$

Then, the model response is characterized as follows (cf. [126, 125])

$$f < 0 \Leftrightarrow \text{elastic range} \quad , \quad (12.104)$$

$$f = 0 \quad \& \quad L \left\{ \begin{array}{l} < 0 \\ = 0 \\ > 0 \end{array} \right\} \Leftrightarrow \left\{ \begin{array}{l} \text{elastic unloading} \quad , \\ \text{neutral loading} \quad , \\ \text{plastic loading} \quad . \end{array} \right. \quad (12.105)$$

Plastic flow is defined to occur only when conditions for plastic loading apply.

We remark that a cycle in the space of the tensors $\tilde{\epsilon}$, $\tilde{\beta}$, and $\tilde{\mathcal{K}}$ is equivalent to a cycle in the space of any further strain and micromorphic curvature measure. Generalizing a proposal of Lucchesi and Silhavy [114] (cf. also Grammenoudis and Tsakmakis [67], who generalize the postulate to capture micropolar material response), we denote strain-curvature cycles as small (but not necessarily infinitesimally

small), if the following condition is satisfied. During the cyclic process, the initial strain-curvature state is always on or inside the yield surfaces $\tilde{g} = 0$ corresponding to the process. In other words, the initial strain-curvature state always lies in the intersection of all the elastic ranges surrounded by the yield surfaces $\tilde{g} = 0$ during the process.

We write $C_s[t_0, t_e]$ for a small cycle, which begins at time t_0 , and ends at time t_e . A plastically deformable micromorphic material is defined to satisfy the postulate of Il'iushin for small cycles, if for a fixed material particle

$$\begin{aligned} I(t_0, t_e) &:= \frac{1}{\varrho\mathcal{R}} \int_{t_0}^{t_e} \mathbf{S} \cdot \dot{\hat{\boldsymbol{\epsilon}}} dt + \frac{1}{\varrho\mathcal{R}} \int_{t_0}^{t_e} \boldsymbol{\sigma} \cdot \dot{\hat{\boldsymbol{\beta}}} dt + \frac{1}{\varrho\mathcal{R}} \int_{t_0}^{t_e} \mathbf{S} \cdot \dot{\hat{\boldsymbol{\kappa}}} dt \\ &= \frac{1}{\varrho\mathcal{R}} \int_{t_0}^{t_e} \tilde{\mathbf{S}} \cdot \dot{\tilde{\boldsymbol{\epsilon}}} dt + \frac{1}{\varrho\mathcal{R}} \int_{t_0}^{t_e} \tilde{\boldsymbol{\sigma}} \cdot \dot{\tilde{\boldsymbol{\beta}}} dt + \frac{1}{\varrho\mathcal{R}} \int_{t_0}^{t_e} \tilde{\mathbf{S}} \cdot \dot{\tilde{\boldsymbol{\kappa}}} dt \geq 0 \quad \text{for every } C_s[t_0, t_e] \quad . \end{aligned} \quad (12.106)$$

In Sect. 12.5 it is proven that (12.106) is equivalent to

$$\hat{\mathbf{P}} \cdot \hat{\boldsymbol{\epsilon}}_p + \hat{\boldsymbol{\Pi}} \cdot \hat{\boldsymbol{\beta}}_p + \hat{\mathbf{S}} \cdot \hat{\boldsymbol{\kappa}}_p \geq \hat{\mathbf{P}}^{(A)} \cdot \hat{\boldsymbol{\epsilon}}_p + \hat{\boldsymbol{\Pi}}^{(A)} \cdot \hat{\boldsymbol{\beta}}_p + \hat{\mathbf{S}}^{(A)} \cdot \hat{\boldsymbol{\kappa}}_p \quad , \quad (12.107)$$

where $(\hat{\mathbf{P}}, \hat{\boldsymbol{\Pi}}, \hat{\mathbf{S}})$ is a stress state on the yield surface, which induces the plastic strain-curvature rates $(\hat{\boldsymbol{\epsilon}}_p, \hat{\boldsymbol{\beta}}_p, \hat{\boldsymbol{\kappa}}_p)$. The stress state $(\hat{\mathbf{P}}^{(A)}, \hat{\boldsymbol{\Pi}}^{(A)}, \hat{\mathbf{S}}^{(A)})$ is a so-called admissible stress state, i.e. a stress state which is accessible and is on or inside the yield surface, $\hat{f}(\hat{\mathbf{P}}^{(A)}, \hat{\boldsymbol{\Pi}}^{(A)}, \hat{\mathbf{S}}^{(A)}, \hat{\mathbf{h}}^{(A)}) \leq 0$.

If one introduces the notation

$$\hat{\boldsymbol{\mathcal{U}}} := (\hat{\boldsymbol{\epsilon}}_p, \hat{\boldsymbol{\beta}}_p, \hat{\boldsymbol{\kappa}}_p) \quad , \quad \hat{\mathbf{s}} := (\hat{\mathbf{P}}, \hat{\boldsymbol{\Pi}}, \hat{\mathbf{S}}) \quad , \quad (12.108)$$

then (12.106) is equivalent to

$$\hat{\mathbf{s}} \cdot \hat{\boldsymbol{\mathcal{U}}} \geq \hat{\mathbf{s}}^A \cdot \hat{\boldsymbol{\mathcal{U}}} \quad . \quad (12.109)$$

As the plastic power of the micromorphic material may be expressed in terms of $\hat{\mathbf{s}}, \hat{\boldsymbol{\mathcal{U}}}$,

$$w_{pl} := \hat{\mathbf{P}} \cdot \hat{\boldsymbol{\epsilon}}_p + \hat{\boldsymbol{\Pi}} \cdot \hat{\boldsymbol{\beta}}_p + \hat{\mathbf{S}} \cdot \hat{\boldsymbol{\kappa}}_p \equiv \hat{\mathbf{s}} \cdot \hat{\boldsymbol{\mathcal{U}}} \quad , \quad (12.110)$$

inequality (12.109) represents a so-called principle of maximum plastic stress power, which is a natural extension of the corresponding principle of maximum plastic stress power in classical plasticity. The physical interpretation of (12.109) may be seen by using the definition

$$\bar{f}(\hat{\mathbf{s}}, \hat{\mathbf{h}}) := \hat{f}(\hat{\mathbf{P}}, \hat{\boldsymbol{\Pi}}, \hat{\mathbf{S}}, \hat{\mathbf{h}}) \quad . \quad (12.111)$$

Then, with respect to a pure mechanical formulation of the theory, inequality (12.109) states that, for a given plastic rate $\hat{\boldsymbol{\mathcal{U}}}$, among all admissible stress states $\hat{\mathbf{s}}^A$, the actual stress state $\hat{\mathbf{s}}$ maximizes the plastic power w_{pl} .

For isothermal deformations with uniform distribution, we deal with here, the internal dissipation is given by (cf. (12.99))

$$\mathcal{D}(\hat{\mathbf{s}}, \hat{\boldsymbol{\mathcal{U}}}, \dot{\Psi}_p) = \hat{\mathbf{s}} \cdot \hat{\boldsymbol{\mathcal{U}}} - \varrho\mathcal{R} \dot{\Psi}_p \quad . \quad (12.112)$$

Keeping in mind this equation, (12.109) states that for given internal state variables and their rates, i.e. for given $\overset{\Delta}{\mathbf{U}}$ and $\dot{\Psi}_p$, among all admissible stresses $\hat{\mathbf{s}}^A$ the actual one $\hat{\mathbf{s}}$ maximizes \mathcal{D} .

As in classical plasticity (see e.g. Lubliner [113, Sect. 3.2.2]), the convexity of the yield surface $\bar{f} = 0$, and the normality rule for $\overset{\Delta}{\mathbf{U}}$, are sufficient conditions for inequality (12.109) to hold. This means that (12.109) is always satisfied, if $\overset{\Delta}{\mathbf{U}}$ is directed along the outward normal on the yield surface $\bar{f} = 0$, which has been assumed to be smooth,

$$\overset{\Delta}{\mathbf{U}} = \dot{s} \frac{\frac{\partial \bar{f}}{\partial \hat{\mathbf{s}}}}{\left\| \frac{\partial \bar{f}}{\partial \hat{\mathbf{s}}} \right\|} , \quad (12.113)$$

or, equivalently

$$\overset{\Delta}{\hat{\boldsymbol{\epsilon}}}_p = \dot{s} \frac{\frac{\partial \hat{f}}{\partial \hat{\mathbf{P}}}}{\left\| \frac{\partial \hat{f}}{\partial \hat{\mathbf{P}}} \right\|} , \quad \overset{\Delta}{\hat{\boldsymbol{\beta}}}_p = \dot{s} \frac{\frac{\partial \hat{f}}{\partial \hat{\boldsymbol{\Pi}}}}{\left\| \frac{\partial \hat{f}}{\partial \hat{\boldsymbol{\Pi}}} \right\|} , \quad \overset{\Delta}{\hat{\boldsymbol{\kappa}}}_p = \dot{s} \frac{\frac{\partial \hat{f}}{\partial \hat{\boldsymbol{\mathcal{S}}}}}{\left\| \frac{\partial \hat{f}}{\partial \hat{\boldsymbol{\mathcal{S}}}}} \right\|} , \quad (12.114)$$

with

$$\left\| \frac{\partial \bar{f}}{\partial \hat{\mathbf{s}}} \right\| := \sqrt{\frac{\partial \hat{f}}{\partial \hat{\mathbf{P}}} \cdot \frac{\partial \hat{f}}{\partial \hat{\mathbf{P}}} + \frac{\partial \hat{f}}{\partial \hat{\boldsymbol{\Pi}}} \cdot \frac{\partial \hat{f}}{\partial \hat{\boldsymbol{\Pi}}} + \frac{\partial \hat{f}}{\partial \hat{\boldsymbol{\mathcal{S}}}} \cdot \frac{\partial \hat{f}}{\partial \hat{\boldsymbol{\mathcal{S}}}}} . \quad (12.115)$$

\dot{s} is a positive scalar for plastic loading, which has to be determined from the so-called consistency condition $\dot{f} = 0$. We see from (12.113)–(12.115) that

$$\dot{s} = \sqrt{\overset{\Delta}{\mathbf{U}} \cdot \overset{\Delta}{\mathbf{U}}} := \sqrt{\overset{\Delta}{\hat{\boldsymbol{\epsilon}}}_p \cdot \overset{\Delta}{\hat{\boldsymbol{\epsilon}}}_p + \overset{\Delta}{\hat{\boldsymbol{\beta}}}_p \cdot \overset{\Delta}{\hat{\boldsymbol{\beta}}}_p + \overset{\Delta}{\hat{\boldsymbol{\kappa}}}_p \cdot \overset{\Delta}{\hat{\boldsymbol{\kappa}}}_p} . \quad (12.116)$$

Clearly, convexity of $\bar{f}(\hat{\mathbf{s}}, \hat{\mathbf{h}}) = 0$ with respect to $\hat{\mathbf{s}}$ is equivalent to convexity of $\hat{f}(\hat{\mathbf{P}}, \hat{\boldsymbol{\Pi}}, \hat{\boldsymbol{\mathcal{S}}}, \hat{\mathbf{h}}) = 0$ with respect to $\hat{\mathbf{P}}, \hat{\boldsymbol{\Pi}}, \hat{\boldsymbol{\mathcal{S}}}$.

Plastic incompressibility is defined by the constraints

$$\det \mathbf{F}_p = \det \mathbf{f}_p = 1 \quad \Leftrightarrow \quad \text{tr} \hat{\mathbf{L}}_p = \text{tr} \hat{\mathbf{l}}_p = \text{tr} \overset{\Delta}{\hat{\boldsymbol{\epsilon}}}_p = \text{tr} \overset{\Delta}{\hat{\boldsymbol{\beta}}}_p = 0 . \quad (12.117)$$

If this is assumed, then the yield function must have such a form that $\frac{\partial \hat{f}}{\partial \hat{\mathbf{P}}}$ and $\frac{\partial \hat{f}}{\partial \hat{\boldsymbol{\Pi}}}$ are deviatoric.

Note in passing, that in contrast to the very interesting approach of Ehlers (see e.g. [42, 41, 43]), $\overset{\Delta}{\hat{\boldsymbol{\kappa}}}_p$ does not satisfy any compatibility conditions. This is the reason why evolution equations for $\overset{\Delta}{\hat{\boldsymbol{\kappa}}}_p$ are necessary. Also several yield functions, corresponding to multi-mechanism plasticity have been suggested by Forest and Sievert [55]. This could be an alternative approach, which may be more proper when discussing practical problems.

12.3.3 Flow rule for viscoplasticity

Consider micromorphic viscoplasticity models which arise from those of micromorphic plasticity by adopting all the constitutive equations except for the evolution equation for s . This is now defined in a quite similar way as in classical viscoplasticity in terms of a so-called over-stress. Thus, whereas for rate-independent micromorphic plasticity the yield function is subject to the constraint $f = \hat{f}(\mathbf{P}, \hat{\mathbf{P}}, \hat{\mathbf{S}}, \hat{\mathbf{h}}) \leq 0$, in the case of micromorphic viscoplasticity no such restrictions on f are imposed. We call a positive value of f an overstress, so that \dot{s} is supposed to be given as a function of $\langle f \rangle$. As an example, we propose the evolution equation (cf. [18])

$$\dot{s} = \frac{\langle f \rangle^m}{\eta} \geq 0 \quad , \quad (12.118)$$

with m and η being positive material parameters.

12.3.4 Hardening rules

We suppose the micromorphic material to exhibit isotropic and kinematic hardening. Let r be a scalar valued internal state variable responsible for isotropic hardening. With respect to the plastic intermediate configuration, we introduce strain and micromorphic curvature tensors $\hat{\boldsymbol{\epsilon}}_k, \hat{\boldsymbol{\beta}}_k, \hat{\boldsymbol{\mathcal{K}}}_k$, responsible for kinematic hardening, so that the additive decompositions

$$\hat{\boldsymbol{\epsilon}}_p = \hat{\boldsymbol{\epsilon}}_k + \hat{\boldsymbol{\epsilon}}_d \quad , \quad \hat{\boldsymbol{\beta}}_p = \hat{\boldsymbol{\beta}}_k + \hat{\boldsymbol{\beta}}_d \quad , \quad \hat{\boldsymbol{\mathcal{K}}}_p = \hat{\boldsymbol{\mathcal{K}}}_k + \hat{\boldsymbol{\mathcal{K}}}_d \quad , \quad (12.119)$$

apply. The index d indicates that the corresponding variables are related with the work dissipated as heat. We think of the additive decompositions (12.119) to be induced by multiplicative decompositions of $\mathbf{F}_p, \mathbf{f}_p$,

$$\mathbf{F}_p = \mathbf{F}_k \mathbf{F}_d \quad , \quad \mathbf{f}_p = \mathbf{f}_k \mathbf{f}_d \quad , \quad (12.120)$$

with $\det \mathbf{F}_k > 0, \det \mathbf{f}_k > 0$. $\mathbf{F}_k, \mathbf{f}_k$ introduce a new intermediate configuration $\check{\mathcal{R}}_t$, characterized by the property that the stress and back-stress tensors are vanishing there. According to our work until now, it is a straightforward matter to establish the kinematical relations given in Sect. 12.7, which are similar to those in Sect. 12.6.

Following classical proposals (see e.g. [36]), we assume the additive decomposition for Ψ_p

$$\Psi_p(t) = \Psi_{is}(t) + \Psi_k(t) \quad (12.121)$$

with

$$\Psi_{is} = \bar{\Psi}_{is}(r) \quad , \quad \Psi_k = \hat{\Psi}_k(\hat{\boldsymbol{\epsilon}}_k, \hat{\boldsymbol{\beta}}_k, \hat{\boldsymbol{\mathcal{K}}}_k) \quad . \quad (12.122)$$

It is convenient to introduce the stresses

$$R := \varrho_{\mathcal{R}} \frac{\partial \bar{\Psi}_{is}}{\partial r} \quad , \quad \hat{\mathbf{S}}_k := \varrho_{\mathcal{R}} \frac{\partial \hat{\Psi}_k}{\partial \hat{\boldsymbol{\epsilon}}_k} \quad , \quad \hat{\boldsymbol{\sigma}}_k := \varrho_{\mathcal{R}} \frac{\partial \hat{\Psi}_k}{\partial \hat{\boldsymbol{\beta}}_k} \quad , \quad \hat{\mathbf{S}}_k := \varrho_{\mathcal{R}} \frac{\partial \hat{\Psi}_k}{\partial \hat{\boldsymbol{\mathcal{K}}}_k} \quad . \quad (12.123)$$

R denotes the scalar valued stress modeling isotropic hardening, so that the yield stress k is given by

$$k := R + \bar{k}_0 \quad , \quad \bar{k}_0 = \text{const.} \geq 0 \quad . \quad (12.124)$$

Kinematic hardening is modeled by the back-stress tensor $\hat{\mathbf{s}}_k$,

$$\hat{\mathbf{s}}_k := (\hat{\mathbf{P}}_k, \hat{\mathbf{\Pi}}_k, \hat{\mathbf{S}}_k) \quad , \quad (12.125)$$

where the tensors $\hat{\mathbf{P}}_k, \hat{\mathbf{\Pi}}_k$ are defined in the following.

Assume that Ψ_k in (12.122) may be represented also in the form (cf. Eqs. (12.70), (12.76))

$$\Psi_k = \tilde{\Psi}_k(\tilde{\epsilon}_p, \tilde{\beta}_p, \tilde{\mathcal{K}}_p, \tilde{\epsilon}_d, \tilde{\beta}_d, \tilde{\mathcal{K}}_d) \quad . \quad (12.126)$$

Performing mathematical manipulations similar to those in Sect. 12.3.1, we arrive at the results

$$\begin{aligned} \dot{\Psi}_k &= \frac{\partial \hat{\Psi}_k}{\partial \hat{\epsilon}_k} \cdot \overset{\Delta}{\hat{\epsilon}}_k + \frac{\partial \hat{\Psi}_k}{\partial \hat{\beta}_k} \cdot \overset{\Delta}{\hat{\beta}}_k + \frac{\partial \hat{\Psi}_k}{\partial \hat{\mathcal{K}}_k} \cdot \overset{\Delta}{\hat{\mathcal{K}}}_k - \left\{ \hat{\epsilon}_k^T \frac{\partial \hat{\Psi}_k}{\partial \hat{\epsilon}_k} + \frac{1}{\varrho \mathcal{R}} \hat{\eta}_k \right\} \cdot \overset{\Delta}{\hat{\epsilon}}_p \\ &\quad - \left\{ 2\hat{\beta}_k \frac{\partial \hat{\Psi}_k}{\partial \hat{\beta}_k} + \hat{\Lambda}_k \right\}_S \cdot \overset{\Delta}{\hat{\beta}}_p - \left\{ 2\hat{\beta}_k \frac{\partial \hat{\Psi}_k}{\partial \hat{\beta}_k} + \frac{1}{\varrho \mathcal{R}} \hat{\Lambda}_k \right\}_A \cdot \hat{\mathbf{w}}_p \\ &= \frac{\partial \tilde{\Psi}_k}{\partial \tilde{\epsilon}_d} \cdot \dot{\tilde{\epsilon}}_d + \frac{\partial \tilde{\Psi}_k}{\partial \tilde{\beta}_d} \cdot \dot{\tilde{\beta}}_d + \frac{\partial \tilde{\Psi}_k}{\partial \tilde{\mathcal{K}}_d} \cdot \dot{\tilde{\mathcal{K}}}_d + \frac{\partial \tilde{\Psi}_k}{\partial \tilde{\epsilon}_p} \cdot \dot{\tilde{\epsilon}}_p + \frac{\partial \tilde{\Psi}_k}{\partial \tilde{\beta}_p} \cdot \dot{\tilde{\beta}}_p + \frac{\partial \tilde{\Psi}_k}{\partial \tilde{\mathcal{K}}_p} \cdot \dot{\tilde{\mathcal{K}}}_p \quad , \end{aligned} \quad (12.127)$$

from which we deduce

$$-\frac{1}{\varrho \mathcal{R}} \hat{\mathbf{S}}_k = -\frac{\partial \hat{\Psi}_k}{\partial \hat{\epsilon}_k} = \mathbf{f}_p^{T-1} \frac{\partial \tilde{\Psi}_k}{\partial \tilde{\epsilon}_d} \mathbf{F}_p^T \quad , \quad (12.128)$$

$$-\frac{1}{\varrho \mathcal{R}} \hat{\boldsymbol{\sigma}}_k = -\frac{\partial \hat{\Psi}_k}{\partial \hat{\beta}_k} = \mathbf{f}_p \frac{\partial \tilde{\Psi}_k}{\partial \tilde{\beta}_d} \mathbf{f}_p^T \quad , \quad (12.129)$$

$$-\frac{1}{\varrho \mathcal{R}} \hat{\mathbf{S}}_k = -\frac{\partial \hat{\Psi}_k}{\partial \hat{\mathcal{K}}_k} = \mathcal{L}(\mathbf{f}_p^{T-1}, \mathbf{f}_p, \mathbf{F}_p) \left[\frac{\partial \tilde{\Psi}_k}{\partial \tilde{\mathcal{K}}_d} \right] \quad , \quad (12.130)$$

$$\left\{ (\mathbf{1} - \hat{\epsilon}_k^T) \frac{\partial \hat{\Psi}_k}{\partial \hat{\epsilon}_k} - \frac{1}{\varrho \mathcal{R}} \hat{\eta}_k \right\} = \mathbf{f}_p^{T-1} \frac{\partial \tilde{\Psi}_k}{\partial \tilde{\epsilon}_p} \mathbf{F}_p^T \quad , \quad (12.131)$$

$$\left\{ (\mathbf{1} - 2\hat{\beta}_k) \frac{\partial \hat{\Psi}_k}{\partial \hat{\beta}_k} - \hat{\Lambda}_k \right\}_S = \mathbf{f}_p \frac{\partial \tilde{\Psi}_k}{\partial \tilde{\beta}_p} \mathbf{f}_p^T \quad , \quad (12.132)$$

$$\frac{\partial \hat{\Psi}_k}{\partial \hat{\mathcal{K}}_k} = \mathcal{L}(\mathbf{f}_p^{T-1}, \mathbf{f}_p, \mathbf{F}_p) \left[\frac{\partial \tilde{\Psi}_k}{\partial \tilde{\mathcal{K}}_p} \right] \quad , \quad (12.133)$$

$$\left\{ 2\hat{\beta}_k \frac{\partial \hat{\Psi}_k}{\partial \hat{\beta}_k} + \frac{1}{\varrho \mathcal{R}} \hat{\Lambda}_k \right\}_A = 0 \quad , \quad (12.134)$$

with

$$\frac{1}{\varrho \mathcal{R}} \hat{\Lambda}_k := \frac{1}{\varrho \mathcal{R}} \hat{\eta}_k - \frac{1}{\varrho \mathcal{R}} \hat{\chi}_k + \frac{1}{\varrho \mathcal{R}} \{ \hat{\epsilon}_k^T \hat{\mathbf{S}}_k - \hat{\mathbf{S}}_k \hat{\epsilon}_k^T \} \quad , \quad (12.135)$$

$$\frac{1}{\varrho \mathcal{R}} (\hat{\eta}_k)_{ml} := \frac{\partial \hat{\Psi}_k}{\partial (\hat{\mathcal{K}}_k)_{rnl}} (\hat{\mathcal{K}}_k)_{rnm} \quad , \quad (12.136)$$

$$\frac{1}{\varrho_{\mathcal{R}}}(\hat{\mathcal{X}}_k)_{ml} := \frac{\partial \hat{\Psi}_k}{\partial (\hat{\mathcal{K}}_k)_{mnr}}(\hat{\mathcal{K}}_k)_{lnr} - \frac{\partial \hat{\Psi}_k}{\partial (\hat{\mathcal{K}}_k)_{nlr}}(\hat{\mathcal{K}}_k)_{nmr} . \quad (12.137)$$

These relations suggest to define the back-stress tensors $\hat{\mathbf{P}}_k, \hat{\mathbf{\Pi}}_k$ by

$$\hat{\mathbf{P}}_k := (\mathbf{1} - \hat{\boldsymbol{\epsilon}}_k^T) \hat{\mathbf{S}}_k - \hat{\boldsymbol{\eta}}_k , \quad \hat{\mathbf{\Pi}}_k := \left\{ (\mathbf{1} - 2\hat{\boldsymbol{\beta}}_k) \hat{\boldsymbol{\sigma}}_k - \hat{\boldsymbol{\Lambda}}_k \right\}_S . \quad (12.138)$$

This way, $\varrho_{\mathcal{R}} \hat{\Psi}_p$ becomes

$$\varrho_{\mathcal{R}} \hat{\Psi}_p = -\hat{\mathbf{S}}_k \cdot \hat{\boldsymbol{\epsilon}}_d - \hat{\boldsymbol{\sigma}}_k \cdot \hat{\boldsymbol{\beta}}_d - \hat{\mathbf{S}}_k \cdot \hat{\mathcal{K}}_d + \hat{\mathbf{P}}_k \cdot \hat{\boldsymbol{\epsilon}}_p + \hat{\mathbf{\Pi}}_k \cdot \hat{\boldsymbol{\beta}}_p + \hat{\mathbf{S}}_k \cdot \hat{\mathcal{K}}_p + R\dot{r} . \quad (12.139)$$

After inserting in the dissipation inequality (12.99),

$$\mathcal{D} = (\hat{\mathbf{P}} - \hat{\mathbf{P}}_k) \cdot \hat{\boldsymbol{\epsilon}}_p + (\hat{\mathbf{\Pi}} - \hat{\mathbf{\Pi}}_k) \cdot \hat{\boldsymbol{\beta}}_p + (\hat{\mathbf{S}} - \hat{\mathbf{S}}_k) \cdot \hat{\mathcal{K}}_p - R\dot{r} + \hat{\mathbf{S}}_k \cdot \hat{\boldsymbol{\epsilon}}_d + \hat{\boldsymbol{\sigma}}_k \cdot \hat{\boldsymbol{\beta}}_d + \hat{\mathbf{S}}_k \cdot \hat{\mathcal{K}}_d \geq 0 , \quad (12.140)$$

or

$$\mathcal{D} = (\hat{\mathbf{s}} - \hat{\mathbf{s}}_k) \cdot \hat{\boldsymbol{\mathcal{U}}} - R\dot{r} + \hat{\mathbf{s}}_d \cdot \hat{\boldsymbol{\mathcal{U}}}_d \geq 0 , \quad (12.141)$$

where

$$\hat{\mathbf{s}}_d := (\hat{\mathbf{S}}_k, \hat{\boldsymbol{\sigma}}_k, \hat{\mathbf{S}}_k) , \quad \hat{\boldsymbol{\mathcal{U}}}_d := (\hat{\boldsymbol{\epsilon}}_d, \hat{\boldsymbol{\beta}}_d, \hat{\mathcal{K}}_d) . \quad (12.142)$$

We separate effects due to isotropic hardening from those due to kinematic hardening by requiring the two inequalities

$$\mathcal{D}_{is} := (\hat{\mathbf{s}} - \hat{\mathbf{s}}_k) \cdot \hat{\boldsymbol{\mathcal{U}}} - R\dot{r} \geq 0 , \quad (12.143)$$

$$\mathcal{D}_k := \hat{\mathbf{s}}_d \cdot \hat{\boldsymbol{\mathcal{U}}}_d \geq 0 , \quad (12.144)$$

which are sufficient conditions for (12.141).

12.3.4.1 Isotropic hardening

Let the yield function in (12.111) obey the representation

$$f(t) = \bar{f}(\hat{\mathbf{s}} - \hat{\mathbf{s}}_k) - k \equiv \bar{f}(\hat{\mathbf{s}} - \hat{\mathbf{s}}_k) - R - \bar{k}_0 , \quad (12.145)$$

with \bar{f} being a homogeneous function of degree one, so that, according to Euler's theorem,

$$\frac{\partial \bar{f}}{\partial (\hat{\mathbf{s}} - \hat{\mathbf{s}}_k)} \cdot (\hat{\mathbf{s}} - \hat{\mathbf{s}}_k) = \bar{f} . \quad (12.146)$$

We recall from the normality rule (12.113) that (12.143) is equivalent to

$$\mathcal{D}_{is} = (\hat{\mathbf{s}} - \hat{\mathbf{s}}_k) \cdot \dot{\hat{\mathbf{s}}} \frac{\frac{\partial \bar{f}}{\partial (\hat{\mathbf{s}} - \hat{\mathbf{s}}_k)}}{\left\| \frac{\partial \bar{f}}{\partial (\hat{\mathbf{s}} - \hat{\mathbf{s}}_k)} \right\|} - R\dot{r} \geq 0 , \quad (12.147)$$

or, by virtue of (12.146),

$$\mathcal{D}_{is} = \dot{s} \frac{\bar{f}}{\zeta} - R\dot{r} \geq 0 \quad , \quad \zeta := \left\| \frac{\partial \bar{f}}{\partial (\hat{s} - \hat{s}_k)} \right\| \quad . \quad (12.148)$$

When inelastic flow is involved, $f = 0 \Leftrightarrow \bar{f} = k$ for plasticity, and $f \geq 0 \Leftrightarrow \bar{f} \geq k$ for viscoplasticity. Hence, we conclude that

$$\dot{s} \frac{k}{\zeta} - R\dot{r} \geq 0 \quad (12.149)$$

is a sufficient condition for (12.148). Keeping in mind (12.124), it follows that (12.149) is equivalent to

$$R \left(\frac{\dot{s}}{\zeta} - \dot{r} \right) + \bar{k}_0 \frac{\dot{s}}{\zeta} \geq 0 \quad . \quad (12.150)$$

Since $\bar{k}_0 \frac{\dot{s}}{\zeta} \geq 0$, it suffices to require

$$R \left(\frac{\dot{s}}{\zeta} - \dot{r} \right) \geq 0 \quad , \quad (12.151)$$

in order to satisfy (12.143) always. A sufficient condition for the validity of the latter reads

$$\frac{\dot{s}}{\zeta} - \dot{r} = \frac{\beta \dot{s}}{\gamma \zeta} (R - R_0) \quad \Leftrightarrow \quad \dot{r} = \left(1 - \frac{\beta}{\gamma} (R - R_0) \right) \frac{\dot{s}}{\zeta} \quad , \quad (12.152)$$

$$R_0 := R|_{r=0} \quad , \quad (12.153)$$

where $\beta \geq 0$, $\gamma \geq 0$ are material parameters subject to the condition $\frac{\beta}{\gamma} \geq 0$.

As a particular example consider the case

$$\Psi_{is} = \bar{\Psi}_{is}(r) = \frac{\gamma}{2\varrho_{\mathcal{R}}} (r^2 + 2r_0 r) \quad \Rightarrow \quad R = \varrho_{\mathcal{R}} \frac{\partial \bar{\Psi}_{is}}{\partial r} = \gamma(r + r_0) \quad . \quad (12.154)$$

Thus,

$$k = R + \bar{k}_0 \quad \Rightarrow \quad k_0 := k|_{r=0} = R_0 + \bar{k}_0 \quad , \quad R_0 = \gamma r_0 \quad , \quad (12.155)$$

and (12.152) is equivalent to

$$\dot{r} = (1 - \beta r) \frac{\dot{s}}{\zeta} \quad , \quad (12.156)$$

or

$$\dot{R} = \{\gamma - \beta(R - R_0)\} \frac{\dot{s}}{\zeta} \quad (12.157)$$

or

$$\dot{k} = \{\gamma - \beta(k - k_0)\} \frac{\dot{s}}{\zeta} \quad . \quad (12.158)$$

In essence, these results for isotropic hardening are similar to those in classical plasticity established by Chaboche (see e.g. [19]).

12.3.4.2 Kinematic hardening

In order to satisfy (12.144),

$$\mathcal{D}_k = \hat{\mathbf{s}}_d \cdot \hat{\mathbf{u}}_d \equiv \hat{\mathbf{S}}_k \cdot \hat{\boldsymbol{\epsilon}}_d + \hat{\boldsymbol{\sigma}}_k \cdot \hat{\boldsymbol{\beta}}_d + \hat{\mathbf{S}}_k \cdot \hat{\boldsymbol{\kappa}}_d \geq 0 \quad , \quad (12.159)$$

it suffices to assume

$$\hat{\boldsymbol{\epsilon}}_d = \hat{\mathbf{M}}_k[\hat{\mathbf{S}}_k] \quad , \quad \hat{\boldsymbol{\beta}}_d = \hat{\mathbf{N}}_k[\hat{\boldsymbol{\sigma}}_k] \quad , \quad \hat{\boldsymbol{\kappa}}_d = \hat{\mathbf{P}}_k[\hat{\mathbf{S}}_k] \quad , \quad (12.160)$$

where $\hat{\mathbf{M}}_k$, $\hat{\mathbf{N}}_k$ are, respectively, semi-definite isotropic fourth-order tensors, and $\hat{\mathbf{P}}_k$ is a semi-definite isotropic sixth-order tensor. Clearly, the evolution equations (12.160) may be rewritten in the form

$$\hat{\boldsymbol{\epsilon}}_k = \hat{\boldsymbol{\epsilon}}_p - \hat{\mathbf{M}}_k[\hat{\mathbf{S}}_k] \quad , \quad (12.161)$$

$$\hat{\boldsymbol{\beta}}_k = \hat{\boldsymbol{\beta}}_p - \hat{\mathbf{N}}_k[\hat{\boldsymbol{\sigma}}_k] \quad , \quad (12.162)$$

$$\hat{\boldsymbol{\kappa}}_k = \hat{\boldsymbol{\kappa}}_p - \hat{\mathbf{P}}_k[\hat{\mathbf{S}}_k] \quad . \quad (12.163)$$

These evolution equations represent generalized Armstrong-Frederick rules (cf. [7]) for the micromorphic material as adopted here.

12.3.5 Coupling with damage

Micromorphic plasticity models have considerable influence whenever localization phenomena are studied. Such phenomena can result as a consequence of some softening mechanisms inherent in the model response. Damage models induce softening and are employed to describe the progressive material degradation due to the loading process. A simple damage model arises if one assumes the concept of effective stresses combined with the principle of strain equivalence. This approach has been initiated and intensively investigated by Lemaitre and Chaboche [107] (see e.g. [21, 103]) (A comprehensive study is also given in [137].) We shall now apply this approach in our micropolar plasticity to capture damage effects.

We start from the second law of thermodynamics (12.69) and assume again the additive decomposition (12.67). But now, Ψ_e and Ψ_p depend also on the scalar damage variable D :

$$\Psi(t) = \hat{\Psi}(\hat{\boldsymbol{\epsilon}}_e, \hat{\boldsymbol{\beta}}_e, \hat{\boldsymbol{\kappa}}_e, \hat{\boldsymbol{\epsilon}}_k, \hat{\boldsymbol{\beta}}_k, \hat{\boldsymbol{\kappa}}_k, r, D) = \Psi_e(t) + \Psi_p(t) \quad , \quad \Psi_p = \Psi_{is} + \Psi_k \quad , \quad (12.164)$$

$$\Psi_e = \hat{\Psi}_e(\hat{\boldsymbol{\epsilon}}_e, \hat{\boldsymbol{\beta}}_e, \hat{\boldsymbol{\kappa}}_e, D) \quad , \quad \Psi_{is} = \bar{\Psi}_{is}(r, D) \quad , \quad \Psi_k = \hat{\Psi}_k(\hat{\boldsymbol{\epsilon}}_k, \hat{\boldsymbol{\beta}}_k, \hat{\boldsymbol{\kappa}}_k, D) \quad . \quad (12.165)$$

This is the simplest possibility to describe isotropic damage. It is assumed that $D \in [0, 1]$. The values $D = 0$ and $D = 1$ correspond to the undamaged state and the complete local rupture, respectively, while $D \in (0, 1)$ reflects a partially damaged state.

Quite similar to the approach until now, we establish the relations

$$\hat{\mathbf{S}} = \varrho_{\mathcal{R}} \frac{\partial \hat{\Psi}_e}{\partial \hat{\boldsymbol{\epsilon}}_e} \quad , \quad \hat{\boldsymbol{\sigma}} = \varrho_{\mathcal{R}} \frac{\partial \hat{\Psi}_e}{\partial \hat{\boldsymbol{\beta}}_e} \quad , \quad \hat{\mathbf{S}} = \varrho_{\mathcal{R}} \frac{\partial \hat{\Psi}_e}{\partial \hat{\boldsymbol{\kappa}}_e} \quad , \quad (12.166)$$

$$R := \varrho_{\mathcal{R}} \frac{\partial \bar{\Psi}_{is}}{\partial r} \quad , \quad \hat{\mathbf{S}}_k := \varrho_{\mathcal{R}} \frac{\partial \hat{\Psi}_k}{\partial \hat{\boldsymbol{\epsilon}}_k} \quad , \quad \hat{\boldsymbol{\sigma}}_k := \varrho_{\mathcal{R}} \frac{\partial \hat{\Psi}_k}{\partial \hat{\boldsymbol{\beta}}_k} \quad , \quad \hat{\mathbf{S}}_k := \varrho_{\mathcal{R}} \frac{\partial \hat{\Psi}_k}{\partial \hat{\boldsymbol{\mathcal{K}}}_k} \quad , \quad (12.167)$$

$$\begin{aligned} \mathcal{D} = & (\hat{\mathbf{P}} - \hat{\mathbf{P}}_k) \cdot \hat{\boldsymbol{\epsilon}}_p + (\hat{\boldsymbol{\Pi}} - \hat{\boldsymbol{\Pi}}_k) \cdot \hat{\boldsymbol{\beta}}_p + (\hat{\mathbf{S}} - \hat{\mathbf{S}}_k) \cdot \hat{\boldsymbol{\mathcal{K}}}_p - R\dot{r} \\ & + \hat{\mathbf{S}}_k \cdot \hat{\boldsymbol{\epsilon}}_d + \hat{\boldsymbol{\sigma}}_k \cdot \hat{\boldsymbol{\beta}}_d + \hat{\mathbf{S}}_k \cdot \hat{\boldsymbol{\mathcal{K}}}_d - \varrho_{\mathcal{R}} \frac{\partial \hat{\Psi}}{\partial D} \dot{D} \geq 0 \quad , \end{aligned} \quad (12.168)$$

where the stresses $\hat{\mathbf{P}}, \hat{\boldsymbol{\Pi}}, \hat{\mathbf{S}}, \hat{\mathbf{S}}_k, \hat{\boldsymbol{\sigma}}_k, \hat{\mathbf{S}}_k, \hat{\mathbf{P}}, \hat{\boldsymbol{\Pi}}, \hat{\mathbf{P}}_k, \hat{\boldsymbol{\Pi}}_k, R$ are defined as above, but with Ψ given by (12.164) and (12.165).

According to the version of the principle of strain equivalence as adopted here, the constitutive equations governing the response of the real, damaged material may be gained as follows. At every material point, we assign to the real material a fictitious, undamaged material which obeys the constitutive laws established in Sects. 12.3.3 and 12.3.4, but with the variables of stress replaced by so-called effective stresses. The strains for the real and the fictitious material are assumed to be equal (strain equivalence).

To elaborate, let \mathbf{X} be any one of the stress variables $\hat{\mathbf{S}}, \hat{\boldsymbol{\sigma}}, \hat{\mathbf{S}}, R, \hat{\mathbf{S}}_k, \hat{\boldsymbol{\sigma}}_k, \hat{\mathbf{S}}_k, \hat{\mathbf{P}}, \hat{\boldsymbol{\Pi}}, \hat{\mathbf{P}}_k, \hat{\boldsymbol{\Pi}}_k$. The corresponding effective stress $\mathbf{X}^{(eff)}$ is defined by

$$\mathbf{X}^{(eff)} := \frac{\mathbf{X}}{1 - D} \quad . \quad (12.169)$$

Then, from (12.92)–(12.94) we obtain

$$\hat{\mathbf{S}}^{(eff)} = \varrho_{\mathcal{R}} \frac{\partial \hat{\Psi}_e^{(f)}}{\partial \hat{\boldsymbol{\epsilon}}_e} \quad , \quad \hat{\boldsymbol{\sigma}}^{(eff)} = \varrho_{\mathcal{R}} \frac{\partial \hat{\Psi}_e^{(f)}}{\partial \hat{\boldsymbol{\beta}}_e} \quad , \quad \hat{\mathbf{S}}^{(eff)} = \varrho_{\mathcal{R}} \frac{\partial \hat{\Psi}_e^{(f)}}{\partial \hat{\boldsymbol{\mathcal{K}}}_e} \quad , \quad (12.170)$$

where

$$\Psi_e^{(f)} = \hat{\Psi}_e^{(f)}(\hat{\boldsymbol{\epsilon}}_e, \hat{\boldsymbol{\beta}}_e, \hat{\boldsymbol{\mathcal{K}}}_e) \quad (12.171)$$

is the specific free energy for the fictitious materials. Here and in the sequel, the superfix f denotes the fictitious material. Eqs. (12.166), (12.169), and (12.170) imply, after integration,

$$\hat{\Psi}_e(\hat{\boldsymbol{\epsilon}}_e, \hat{\boldsymbol{\beta}}_e, \hat{\boldsymbol{\mathcal{K}}}_e, D) = (1 - D) \hat{\Psi}_e^{(f)}(\hat{\boldsymbol{\epsilon}}_e, \hat{\boldsymbol{\beta}}_e, \hat{\boldsymbol{\mathcal{K}}}_e) \quad . \quad (12.172)$$

Similarly, we have

$$\bar{\Psi}_{is}(r, D) = (1 - D) \bar{\Psi}_{is}^{(f)}(r) \quad , \quad \hat{\Psi}_k(\hat{\boldsymbol{\epsilon}}_k, \hat{\boldsymbol{\beta}}_k, \hat{\boldsymbol{\mathcal{K}}}_k, D) = (1 - D) \hat{\Psi}_k^{(f)}(\hat{\boldsymbol{\epsilon}}_k, \hat{\boldsymbol{\beta}}_k, \hat{\boldsymbol{\mathcal{K}}}_k) \quad . \quad (12.173)$$

Since only isotropic and kinematic hardening are assumed to be present, the yield function reads

$$f = \bar{F}(\hat{\mathbf{s}} - \hat{\mathbf{s}}_k, R, D) = \bar{f}^{(f)}(\hat{\mathbf{s}}^{(eff)} - \hat{\mathbf{s}}_k^{(eff)}) - R^{(eff)} - \bar{k}_0 \quad , \quad (12.174)$$

in view of (12.145), and the flow rule (12.114) becomes

$$\hat{\boldsymbol{\epsilon}}_p = \dot{s} \frac{\partial \bar{F}}{\partial \hat{\mathbf{P}}} \quad , \quad \hat{\boldsymbol{\beta}}_p = \dot{s} \frac{\partial \bar{F}}{\partial \hat{\boldsymbol{\Pi}}} \quad , \quad \hat{\boldsymbol{\mathcal{K}}}_p = \dot{s} \frac{\partial \bar{F}}{\partial \hat{\mathbf{S}}} \quad , \quad (12.175)$$

$$\zeta := \left\| \frac{\partial \bar{F}}{\partial \hat{\mathbf{s}}} \right\| = \frac{1}{1-D} \left\| \frac{\partial \bar{f}^{(f)}(\hat{\mathbf{s}}^{(eff)} - \hat{\mathbf{s}}_k^{(eff)})}{\partial \hat{\mathbf{s}}^{(eff)}} \right\| , \quad (12.176)$$

$$\dot{s} = \sqrt{\hat{\boldsymbol{\epsilon}}_p \cdot \hat{\boldsymbol{\epsilon}}_p + \hat{\boldsymbol{\beta}}_p \cdot \hat{\boldsymbol{\beta}}_p + \hat{\boldsymbol{\kappa}}_p \cdot \hat{\boldsymbol{\kappa}}_p} . \quad (12.177)$$

The isotropic hardening rule in Sect. 12.3.4.1 suggests

$$\Psi_{is} = \frac{\gamma(1-D)}{2\varrho_{\mathcal{R}}}(r^2 + 2r_0r) \quad , \quad \frac{R}{1-D} = \gamma(r + r_0) \quad , \quad (12.178)$$

$$\dot{r} = (1 - \beta r) \frac{\dot{s}}{\zeta} = \left(1 - \frac{\beta}{\gamma} \left(\frac{R}{1-D} - \gamma r_0 \right) \right) \frac{\dot{s}}{\zeta} , \quad (12.179)$$

with ζ , R_0 being defined as in (12.176) and (12.153), respectively. From the kinematic hardening law in (12.161)–(12.163), we get

$$\hat{\boldsymbol{\epsilon}}_k = \hat{\boldsymbol{\epsilon}}_p - \dot{s} \hat{\mathbf{M}}_k [\hat{\mathbf{S}}_k^{(eff)}] = \hat{\boldsymbol{\epsilon}}_p - \frac{\dot{s}}{(1-D)} \hat{\mathbf{M}}_k [\hat{\mathbf{S}}_k] \quad , \quad (12.180)$$

$$\hat{\boldsymbol{\beta}}_k = \hat{\boldsymbol{\beta}}_p - \dot{s} \hat{\mathbf{N}}_k [\hat{\boldsymbol{\sigma}}_k^{(eff)}] = \hat{\boldsymbol{\beta}}_p - \frac{\dot{s}}{(1-D)} \hat{\mathbf{N}}_k [\hat{\boldsymbol{\sigma}}_k] \quad , \quad (12.181)$$

$$\hat{\boldsymbol{\kappa}}_k = \hat{\boldsymbol{\kappa}}_p - \dot{s} \hat{\mathbf{P}}_k [\hat{\mathbf{S}}_k^{(eff)}] = \hat{\boldsymbol{\kappa}}_p - \frac{\dot{s}}{(1-D)} \hat{\mathbf{P}}_k [\hat{\mathbf{S}}_k] \quad . \quad (12.182)$$

It remains to verify whether the dissipation inequality is satisfied. To this end, we insert into (12.168) to obtain

$$\begin{aligned} \mathcal{D} &= (\hat{\mathbf{s}} - \hat{\mathbf{s}}_k) \cdot \dot{s} \frac{\frac{\partial \bar{f}^{(f)}(\hat{\mathbf{s}}^{(eff)} - \hat{\mathbf{s}}_k^{(eff)})}{\partial (\hat{\mathbf{s}} - \hat{\mathbf{s}}_k)}}{\zeta} - R\dot{r} \\ &\quad + \frac{\dot{s}}{1-D} \left\{ \hat{\mathbf{S}}_k \cdot \hat{\mathbf{M}}_k [\hat{\mathbf{S}}_k] + \hat{\boldsymbol{\sigma}}_k \cdot \hat{\mathbf{N}}_k [\hat{\boldsymbol{\sigma}}_k] + \hat{\mathbf{S}}_k \cdot \hat{\mathbf{P}}_k [\hat{\mathbf{S}}_k] \right\} - \varrho_{\mathcal{R}} \frac{\partial \hat{\Psi}}{\partial D} \dot{D} \geq 0 \quad . \end{aligned} \quad (12.183)$$

Since the term in curls is always nonnegative, inequality (12.183) will be satisfied whenever

$$\begin{aligned} &(\hat{\mathbf{s}} - \hat{\mathbf{s}}_k) \cdot \frac{\dot{s}}{\zeta} \frac{\partial \bar{f}^{(f)}}{\partial (\hat{\mathbf{s}} - \hat{\mathbf{s}}_k)} - R\dot{r} - \varrho_{\mathcal{R}} \frac{\partial \hat{\Psi}}{\partial D} \dot{D} \\ &= \left(\hat{\mathbf{s}}^{(eff)} - \hat{\mathbf{s}}_k^{(eff)} \right) \cdot \frac{\dot{s}}{\zeta} \frac{\partial \bar{f}^{(f)}}{\partial (\hat{\mathbf{s}}^{(eff)} - \hat{\mathbf{s}}_k^{(eff)})} - R\dot{r} - \varrho_{\mathcal{R}} \frac{\partial \hat{\Psi}}{\partial D} \dot{D} \\ &\geq \underbrace{R^{(eff)} \frac{\dot{s}}{\zeta}}_{\geq 0} - \underbrace{R \frac{\dot{s}}{\zeta}}_{\geq 0} + \beta R r \frac{\dot{s}}{\zeta} - \varrho_{\mathcal{R}} \frac{\partial \hat{\Psi}}{\partial D} \dot{D} \geq 0 \quad . \end{aligned} \quad (12.184)$$

Thus, the dissipation inequality will always be satisfied, provided

$$-\varrho_{\mathcal{R}} \frac{\partial \hat{\Psi}}{\partial D} \dot{D} \geq 0 \quad . \quad (12.185)$$

A sufficient condition for this inequality reads (cf. [104, 105, 110])

$$\dot{D} = -\alpha_1 \dot{s} \left(\varrho \mathcal{R} \frac{\partial \hat{\Psi}}{\partial D} \right) , \quad (12.186)$$

where $\alpha_1 \geq 0$ denotes a material parameter.

12.3.6 Simple constitutive relations

Various constitutive functions, like free energy or yield function, indicate a simple form if linear, isotropic behavior is assumed to be present. This is expressed in terms of isotropic tensors \mathbf{A} , \mathbf{B} , \mathbf{D} , \mathbf{C} ,

$$\mathbb{A}_{ijpq} = \mathbb{A}_{pqij} = A_1 \delta_{ij} \delta_{pq} + A_2 \delta_{ip} \delta_{jq} + A_3 \delta_{iq} \delta_{jp} , \quad (12.187)$$

$$\mathbb{B}_{ijpq} = \mathbb{B}_{pqij} = \mathbb{B}_{ijqp} = B_1 \delta_{ij} \delta_{pq} + B_2 (\delta_{ip} \delta_{jq} + \delta_{iq} \delta_{jp}) , \quad (12.188)$$

$$\mathbb{D}_{ijpq} = \mathbb{D}_{ijqp} = D_1 \delta_{ij} \delta_{pq} + D_2 (\delta_{ip} \delta_{jq} + \delta_{iq} \delta_{jp}) , \quad (12.189)$$

$$\begin{aligned} \mathcal{C}_{ijkpqr} = \mathcal{C}_{pqrijk} = & C_1 (\delta_{ij} \delta_{kp} \delta_{qr} + \delta_{jk} \delta_{ir} \delta_{pq}) + C_2 (\delta_{ij} \delta_{kq} \delta_{rp} + \delta_{ki} \delta_{jr} \delta_{pq}) \\ & + C_3 \delta_{ij} \delta_{kr} \delta_{pq} + C_4 \delta_{jk} \delta_{ip} \delta_{qr} + C_5 (\delta_{jk} \delta_{iq} \delta_{pr} + \delta_{ki} \delta_{jp} \delta_{qr}) \\ & + C_6 \delta_{ki} \delta_{jq} \delta_{rp} + C_7 \delta_{ip} \delta_{jq} \delta_{kr} + C_8 (\delta_{jp} \delta_{kq} \delta_{ir} + \delta_{kp} \delta_{iq} \delta_{jr}) \\ & + C_9 \delta_{ip} \delta_{jr} \delta_{kq} + C_{10} \delta_{jp} \delta_{kr} \delta_{iq} + C_{11} \delta_{kp} \delta_{ir} \delta_{jq} . \end{aligned} \quad (12.190)$$

12.3.6.1 Elasticity laws

Following Mindlin [122] and Eringen [46], we assume Ψ_e to be given by

$$\begin{aligned} \varrho \mathcal{R} \Psi_e = (1 - D) \left\{ \frac{1}{2} (\mathbf{A}_e)_{ijpq} (\hat{\boldsymbol{\epsilon}}_e)_{ij} (\hat{\boldsymbol{\epsilon}}_e)_{pq} + \frac{1}{2} (\mathbf{B}_e)_{ijpq} (\hat{\boldsymbol{\beta}}_e)_{ij} (\hat{\boldsymbol{\beta}}_e)_{pq} \right. \\ \left. + (\mathbf{D}_e)_{ijpq} (\hat{\boldsymbol{\epsilon}}_e)_{ij} (\hat{\boldsymbol{\beta}}_e)_{pq} + \frac{1}{2} (\mathbf{C}_e)_{ijkpqr} (\hat{\boldsymbol{\kappa}}_e)_{ijk} (\hat{\boldsymbol{\kappa}}_e)_{pqr} \right\} , \end{aligned} \quad (12.191)$$

where \mathbf{A}_e , \mathbf{B}_e , \mathbf{D}_e , \mathbf{C}_e indicate the same form as \mathbf{A} , \mathbf{B} , \mathbf{D} , \mathbf{C} , respectively. The elements of these tensors are denoted, respectively, by A_1^e , A_2^e , A_3^e , B_1^e , B_2^e , D_1^e , D_2^e , C_1^e , C_2^e , \dots , C_{11}^e . In particular we set

$$A_1^e = \lambda , \quad A_2^e = \mu + \alpha , \quad A_3^e = \mu - \alpha . \quad (12.192)$$

Generally, there are involved 18 material parameters, which have to satisfy some conditions in order for Ψ_e to be always non-negative. Such conditions have been worked out by Eringen [46] and Smith [147]. From (12.166), we deduce

$$\hat{\mathbf{S}} = (1 - D) \{ A_1^e (\text{tr} \hat{\boldsymbol{\epsilon}}_e) \mathbf{1} + A_2^e \hat{\boldsymbol{\epsilon}}_e + A_3^e \hat{\boldsymbol{\epsilon}}_e^T + D_1^e (\text{tr} \hat{\boldsymbol{\beta}}_e) \mathbf{1} + 2D_2^e \hat{\boldsymbol{\beta}}_e \} , \quad (12.193)$$

$$\hat{\boldsymbol{\sigma}} = (1 - D) \{ B_1^e (\text{tr} \hat{\boldsymbol{\beta}}_e) \mathbf{1} + 2B_2^e \hat{\boldsymbol{\beta}}_e + D_1^e (\text{tr} \hat{\boldsymbol{\epsilon}}_e) \mathbf{1} + D_2^e (\hat{\boldsymbol{\epsilon}}_e + \hat{\boldsymbol{\epsilon}}_e^T) \} , \quad (12.194)$$

$$\begin{aligned} \hat{\mathbf{S}}_{ijk} = (1 - D) [& \delta_{ij} \{ C_1^e (\hat{\boldsymbol{\kappa}}_e)_{krr} + C_2^e (\hat{\boldsymbol{\kappa}}_e)_{rkr} + C_3^e (\hat{\boldsymbol{\kappa}}_e)_{rrk} \} \\ & + \delta_{jk} \{ C_1^e (\hat{\boldsymbol{\kappa}}_e)_{rri} + C_4^e (\hat{\boldsymbol{\kappa}}_e)_{irr} + C_5^e (\hat{\boldsymbol{\kappa}}_e)_{rir} \} \\ & + \delta_{ki} \{ C_2^e (\hat{\boldsymbol{\kappa}}_e)_{rrj} + C_5^e (\hat{\boldsymbol{\kappa}}_e)_{jrr} + C_6^e (\hat{\boldsymbol{\kappa}}_e)_{rjr} \} \\ & + C_7^e (\hat{\boldsymbol{\kappa}}_e)_{ijk} + C_9^e (\hat{\boldsymbol{\kappa}}_e)_{ikj} + C_{10}^e (\hat{\boldsymbol{\kappa}}_e)_{jik} \\ & + C_{11}^e (\hat{\boldsymbol{\kappa}}_e)_{kji} + C_8^e \{ (\hat{\boldsymbol{\kappa}}_e)_{jki} + (\hat{\boldsymbol{\kappa}}_e)_{kij} \}] . \end{aligned} \quad (12.195)$$

12.3.6.2 Kinematic hardening

Intending to obtain, at the end, a theory for small deformations, we set, in analogy to (12.191),

$$\begin{aligned} \varrho_{\mathcal{R}}\Psi_k = & (1 - D) \left\{ \frac{1}{2}(\mathbf{A}_k)_{ijpq}(\hat{\boldsymbol{\epsilon}}_k)_{ij}(\hat{\boldsymbol{\epsilon}}_k)_{pq} + \frac{1}{2}(\mathbf{B}_k)_{ijpq}(\hat{\boldsymbol{\beta}}_k)_{ij}(\hat{\boldsymbol{\beta}}_k)_{pq} \right. \\ & \left. + (\mathbf{D}_k)_{ijpq}(\hat{\boldsymbol{\epsilon}}_k)_{ij}(\hat{\boldsymbol{\beta}}_k)_{pq} + \frac{1}{2}(\mathbf{C}_k)_{ijkpqr}(\hat{\boldsymbol{\kappa}}_k)_{ijk}(\hat{\boldsymbol{\kappa}}_k)_{pqr} \right\} , \end{aligned} \quad (12.196)$$

where $\mathbf{A}_k, \mathbf{B}_k, \mathbf{D}_k, \mathbf{C}_k$ exhibit the same form as $\mathbf{A}, \mathbf{B}, \mathbf{D}, \mathbf{C}$. Their parameters are $A_1^k, A_2^k, A_3^k, B_1^k, B_2^k, D_1^k, D_2^k, C_1^k, C_2^k, \dots, C_{11}^k$, respectively. It is readily seen, by substituting in (12.167), that $\hat{\mathbf{S}}_k, \hat{\boldsymbol{\sigma}}_k, \hat{\mathbf{S}}_k$ are related to $\hat{\boldsymbol{\epsilon}}_k, \hat{\boldsymbol{\beta}}_k$ and $\hat{\boldsymbol{\kappa}}_k$ in a way similar to that in Eqs. (12.193)–(12.195). Moreover, we suppose $\hat{\mathbf{M}}_k, \hat{\mathbf{N}}_k, \hat{\mathbf{P}}_k$ in (12.180)–(12.182) to exhibit the same form as $\mathbf{A}, \mathbf{B}, \mathbf{C}$ with material parameters $M_1^k, M_2^k, M_3^k, N_1^k, N_2^k, P_1^k, P_2^k, \dots, P_{11}^k$, respectively.

Hence, Eqs. (12.180)–(12.182) yield

$$\hat{\boldsymbol{\epsilon}}_k = \hat{\boldsymbol{\epsilon}}_p - \frac{\dot{s}}{(1-D)} \{M_1^k(\text{tr}\hat{\mathbf{S}}_k)\mathbf{1} + M_2^k\hat{\mathbf{S}}_k + M_3^k\hat{\mathbf{S}}_k^T\} , \quad (12.197)$$

$$\hat{\boldsymbol{\beta}}_k = \hat{\boldsymbol{\beta}}_p - \frac{\dot{s}}{(1-D)} \{N_1^k(\text{tr}\hat{\boldsymbol{\sigma}}_k)\mathbf{1} + 2N_2^k\hat{\boldsymbol{\sigma}}_k\} , \quad (12.198)$$

$$\hat{\boldsymbol{\kappa}}_k = \hat{\boldsymbol{\kappa}}_p - \frac{\dot{s}}{(1-D)} \hat{\mathbf{P}}_k[\hat{\mathbf{S}}_k] . \quad (12.199)$$

12.3.6.3 Yield function – Flow rule

Assuming plastic incompressibility to apply for both, the micro- and the macrocontinuum, we postulate for the yield function in (12.174) the form

$$\begin{aligned} f = \bar{F}(\hat{\mathbf{s}} - \hat{\mathbf{s}}_k, R, D) &= \bar{f}^{(f)}(\hat{\mathbf{s}}^{(eff)} - \hat{\mathbf{s}}_k^{(eff)}) - R^{(eff)} - \bar{k}_0 \\ &= \left(\frac{(\hat{\mathbf{P}} - \hat{\mathbf{P}}_k)^D}{1-D} \cdot \mathbf{A}_y \left[\frac{(\hat{\mathbf{P}} - \hat{\mathbf{P}}_k)^D}{1-D} \right] + \frac{(\hat{\mathbf{\Pi}} - \hat{\mathbf{\Pi}}_k)^D}{1-D} \cdot \mathbf{B}_y \left[\frac{(\hat{\mathbf{\Pi}} - \hat{\mathbf{\Pi}}_k)^D}{1-D} \right] \right. \\ &\quad \left. + \frac{\hat{\mathbf{S}} - \hat{\mathbf{S}}_k}{1-D} \cdot \mathbf{C}_y \left[\frac{\hat{\mathbf{S}} - \hat{\mathbf{S}}_k}{1-D} \right] \right)^{\frac{1}{2}} - \frac{R}{1-D} - \bar{k}_0 . \end{aligned} \quad (12.200)$$

$\mathbf{A}_y, \mathbf{B}_y, \mathbf{C}_y$ indicate the same form as $\mathbf{A}, \mathbf{B}, \mathbf{C}$, with material parameters $A_1^y = 0, A_2^y, A_3^y, B_1^y = 0, B_2^y, C_1^y, \dots, C_{11}^y$.

12.3.6.4 Small deformations

Intrinsic model properties may be discussed appropriately by confining to small deformations, excluding thus effects due to geometrical non-linearities. Let \mathbf{H}, \mathbf{h} be the displacement gradients for the macro- and the microcontinuum,

$$\mathbf{H} := \mathbf{F} - \mathbf{1} , \quad \mathbf{h} := \mathbf{f} - \mathbf{1} . \quad (12.201)$$

Consider the set \mathcal{F} , elements of which are the tensors

$$\mathbf{H}, \mathbf{U}_e - \mathbf{1}, \mathbf{U}_p - \mathbf{1}, \mathbf{h}, \mathbf{u}_e - \mathbf{1}, \mathbf{u}_p - \mathbf{1}, \mathbf{R}_p^T \mathbf{r}_p - \mathbf{1}, \mathbf{R}_e \mathbf{r}_e^T - \mathbf{1}, \tilde{\mathcal{K}}, \tilde{\mathcal{K}}_e, \tilde{\mathcal{K}}_p, \tilde{\beta}_k, \tilde{\epsilon}_k, \tilde{\mathcal{K}}_k, \quad (12.202)$$

as well as their time and spatial (with respect to X^i) derivatives. Let $\varepsilon := \max\{\sup \|A\|/A \in \mathcal{F}\}$ be a measure of smallness, where $\|\cdot\|$ is the Euclidean norm and \sup stands for supremum over the region \mathcal{R}_R . Assume relations of the form

$$\mathbf{H} = \mathbf{O}(\varepsilon) \quad , \quad \mathbf{F} = \mathbf{1} + \mathbf{O}(\varepsilon) \quad , \quad (12.203)$$

$$\mathbf{U}_e = \mathbf{1} + \mathbf{O}(\varepsilon) \quad , \quad \mathbf{U}_p = \mathbf{1} + \mathbf{O}(\varepsilon) \quad , \quad (12.204)$$

$$\mathbf{F}_e = \mathbf{R}_e + \mathbf{O}(\varepsilon) \quad , \quad \mathbf{F}_p = \mathbf{R}_p + \mathbf{O}(\varepsilon) \quad , \quad (12.205)$$

$$\mathbf{h} = \mathbf{O}(\varepsilon) \quad , \quad \mathbf{f} = \mathbf{1} + \mathbf{O}(\varepsilon) \quad , \quad (12.206)$$

$$\mathbf{u}_e = \mathbf{1} + \mathbf{O}(\varepsilon) \quad , \quad \mathbf{u}_p = \mathbf{1} + \mathbf{O}(\varepsilon) \quad , \quad (12.207)$$

$$\mathbf{f}_e = \mathbf{r}_e + \mathbf{O}(\varepsilon) \quad , \quad \mathbf{f}_p = \mathbf{r}_p + \mathbf{O}(\varepsilon) \quad , \quad (12.208)$$

$$\tilde{\beta} = \frac{1}{2}(\mathbf{h} + \mathbf{h}^T) + \mathbf{O}(\varepsilon^2) \quad , \quad \tilde{\beta}_e = \mathbf{O}(\varepsilon) \quad , \quad \tilde{\beta}_p = \mathbf{O}(\varepsilon) \quad , \quad (12.209)$$

$$\beta = \tilde{\beta} + \mathbf{O}(\varepsilon^2) = \hat{\beta} + \mathbf{O}(\varepsilon^2) \quad , \quad \beta_e = \tilde{\beta}_e + \mathbf{O}(\varepsilon^2) = \hat{\beta}_e + \mathbf{O}(\varepsilon^2) \quad , \quad (12.210)$$

$$\beta_p = \tilde{\beta}_p + \mathbf{O}(\varepsilon^2) = \hat{\beta}_p + \mathbf{O}(\varepsilon^2) \quad , \quad (12.211)$$

$$\tilde{\epsilon} = \mathbf{H} - \mathbf{h} + \mathbf{O}(\varepsilon^2) \quad , \quad \tilde{\epsilon}_e = \mathbf{O}(\varepsilon) \quad , \quad \tilde{\epsilon}_p = \mathbf{O}(\varepsilon) \quad , \quad (12.212)$$

$$\epsilon = \tilde{\epsilon} + \mathbf{O}(\varepsilon^2) = \hat{\epsilon} + \mathbf{O}(\varepsilon^2) \quad , \quad \epsilon_e = \tilde{\epsilon}_e + \mathbf{O}(\varepsilon^2) = \hat{\epsilon}_e + \mathbf{O}(\varepsilon^2) \quad , \quad (12.213)$$

$$\epsilon_p = \tilde{\epsilon}_p + \mathbf{O}(\varepsilon^2) = \hat{\epsilon}_p + \mathbf{O}(\varepsilon^2) \quad , \quad (12.214)$$

$$\tilde{\mathcal{K}} = \text{GRADh} + \mathcal{O}(\varepsilon^2) \quad , \quad \tilde{\mathcal{K}}_e = \mathcal{O}(\varepsilon) \quad , \quad \tilde{\mathcal{K}}_p = \mathcal{O}(\varepsilon) \quad , \quad (12.215)$$

$$\mathcal{K} = \tilde{\mathcal{K}} + \mathcal{O}(\varepsilon^2) = \hat{\mathcal{K}} + \mathcal{O}(\varepsilon^2) \quad , \quad (12.216)$$

$$\mathcal{K}_e = \tilde{\mathcal{K}}_e + \mathcal{O}(\varepsilon^2) = \hat{\mathcal{K}}_e + \mathcal{O}(\varepsilon^2) \quad , \quad (12.217)$$

$$\mathcal{K}_p = \tilde{\mathcal{K}}_p + \mathcal{O}(\varepsilon^2) = \hat{\mathcal{K}}_p + \mathcal{O}(\varepsilon^2) \quad , \quad (12.218)$$

$$\hat{\mathbf{S}} = \mathbf{O}(\varepsilon) \quad , \quad \mathbf{S} = \hat{\mathbf{S}} + \mathbf{O}(\varepsilon^2) = \tilde{\mathbf{S}} + \mathbf{O}(\varepsilon^2) = \mathbf{T} + \mathbf{O}(\varepsilon^2) = \hat{\mathbf{P}} + \mathbf{O}(\varepsilon^2) \quad , \quad (12.219)$$

$$\hat{\sigma} = \mathbf{O}(\varepsilon) \quad , \quad \sigma = \hat{\sigma} + \mathbf{O}(\varepsilon^2) = \tilde{\sigma} + \mathbf{O}(\varepsilon^2) = \Sigma + \mathbf{O}(\varepsilon^2) = \hat{\Pi} + \mathbf{O}(\varepsilon^2) \quad , \quad (12.220)$$

$$\hat{\mathbf{S}} = \mathcal{O}(\varepsilon) \quad , \quad \mathbf{S} = \hat{\mathbf{S}} + \mathcal{O}(\varepsilon^2) = \tilde{\mathbf{S}} + \mathcal{O}(\varepsilon^2) = \mathbf{T} + \mathcal{O}(\varepsilon^2) \quad , \quad (12.221)$$

$$\beta_k = \tilde{\beta}_k + \mathbf{O}(\varepsilon^2) = \hat{\beta}_k + \mathbf{O}(\varepsilon^2) \quad , \quad (12.222)$$

⋮

$$\dot{\beta}_p = \overset{\Delta}{\beta}_p + \mathbf{O}(\varepsilon^2) = \dot{\beta} + \mathbf{O}(\varepsilon^2) = \overset{\Delta}{\hat{\beta}} + \mathbf{O}(\varepsilon^2) \quad , \quad (12.223)$$

⋮

$$\varrho = \varrho_R + O(\varepsilon) \quad , \quad (12.224)$$

$$\text{DIVT} = \text{divT} + \mathbf{O}(\varepsilon^2) \quad , \quad (12.225)$$

⋮

to hold. Whenever terms only up to order $O(\varepsilon)$ are explicitly retained, the resulting theory is said to be of small deformations.

Appendix

12.4 Transformations under rigid body rotations superposed on both the current and the plastic intermediate configuration

It can be seen (for some of the subsequent relations cf. [78, 13, 14]) that under rigid body rotations $\mathbf{Q} = \mathbf{Q}(t)$ superposed on the current configuration, and rigid body rotations $\mathbf{Q}_p = \mathbf{Q}_p(t)$ superposed on the plastic intermediate configuration simultaneously, the transformation rules for the macroscopic continuum

$$\mathbf{F} \rightarrow \mathbf{F}^* = \mathbf{Q}\mathbf{F} = \mathbf{Q}\mathbf{F}_e\mathbf{Q}_p^T\mathbf{Q}_p\mathbf{F}_p \quad , \quad (12.226)$$

$$\mathbf{F}_e \rightarrow \mathbf{F}_e^* = \mathbf{Q}\mathbf{F}_e\mathbf{Q}_p^T \quad , \quad \mathbf{F}_p \rightarrow \mathbf{F}_p^* = \mathbf{Q}_p\mathbf{F}_p \quad , \quad (12.227)$$

$$\mathbf{R}_e \rightarrow \mathbf{R}_e^* = \mathbf{Q}\mathbf{R}_e\mathbf{Q}_p^T \quad , \quad \mathbf{R}_p \rightarrow \mathbf{R}_p^* = \mathbf{Q}_p\mathbf{R}_p \quad , \quad (12.228)$$

$$\mathbf{U}_e \rightarrow \mathbf{U}_e^* = \mathbf{Q}_p\mathbf{U}_e\mathbf{Q}_p^T \quad , \quad \mathbf{U}_p \rightarrow \mathbf{U}_p^* = \mathbf{U}_p \quad , \quad (12.229)$$

$$\mathbf{V}_e \rightarrow \mathbf{V}_e^* = \mathbf{Q}\mathbf{V}_e\mathbf{Q}_p^T \quad , \quad \mathbf{V}_p \rightarrow \mathbf{V}_p^* = \mathbf{Q}_p\mathbf{V}_p\mathbf{Q}_p^T \quad , \quad (12.230)$$

$$\hat{\mathbf{L}}_p \rightarrow \hat{\mathbf{L}}_p^* = \mathbf{Q}_p\hat{\mathbf{L}}_p\mathbf{Q}_p^T + \dot{\mathbf{Q}}_p\mathbf{Q}_p^T \quad , \quad (12.231)$$

$$\hat{\mathbf{D}}_p \rightarrow \hat{\mathbf{D}}_p^* = \mathbf{Q}_p\hat{\mathbf{D}}_p\mathbf{Q}_p^T \quad , \quad \hat{\mathbf{W}}_p \rightarrow \hat{\mathbf{W}}_p^* = \mathbf{Q}_p\hat{\mathbf{W}}_p\mathbf{Q}_p^T + \dot{\mathbf{Q}}_p\mathbf{Q}_p^T \quad , \quad (12.232)$$

and for the microcontinuum

$$\mathbf{f} \rightarrow \mathbf{f}^* = \mathbf{Q}\mathbf{f} = \mathbf{Q}\mathbf{f}_e\mathbf{Q}_p^T\mathbf{Q}_p\mathbf{f}_p \quad , \quad (12.233)$$

$$\mathbf{f}_e \rightarrow \mathbf{f}_e^* = \mathbf{Q}\mathbf{f}_e\mathbf{Q}_p^T \quad , \quad \mathbf{f}_p \rightarrow \mathbf{f}_p^* = \mathbf{Q}_p\mathbf{f}_p \quad , \quad (12.234)$$

$$\mathbf{r}_e \rightarrow \mathbf{r}_e^* = \mathbf{Q}\mathbf{r}_e\mathbf{Q}_p^T \quad , \quad \mathbf{r}_p \rightarrow \mathbf{r}_p^* = \mathbf{Q}_p\mathbf{r}_p \quad , \quad (12.235)$$

$$\mathbf{u}_e \rightarrow \mathbf{u}_e^* = \mathbf{Q}_p\mathbf{u}_e\mathbf{Q}_p^T \quad , \quad \mathbf{u}_p \rightarrow \mathbf{u}_p^* = \mathbf{u}_p \quad , \quad (12.236)$$

$$\mathbf{v}_e \rightarrow \mathbf{v}_e^* = \mathbf{Q}\mathbf{v}_e\mathbf{Q}_p^T \quad , \quad \mathbf{v}_p \rightarrow \mathbf{v}_p^* = \mathbf{Q}_p\mathbf{v}_p\mathbf{Q}_p^T \quad , \quad (12.237)$$

apply. Let $\hat{\mathbf{X}}$ denote any one of the tensors $\hat{\beta}, \hat{\beta}_e, \hat{\beta}_p, \hat{\beta}, \hat{\beta}_e, \hat{\beta}_p, \hat{\epsilon}, \hat{\epsilon}_e, \hat{\epsilon}_p, \hat{\epsilon}, \hat{\epsilon}_e, \hat{\epsilon}_p, \hat{\Gamma}, \hat{\Gamma}_e, \hat{\Gamma}_p, \hat{\Gamma}, \hat{\Gamma}_e, \hat{\Gamma}_p$. Then

$$\hat{\mathbf{X}} \rightarrow \hat{\mathbf{X}}^* = \mathbf{Q}_p\hat{\mathbf{X}}\mathbf{Q}_p^T \quad . \quad (12.238)$$

For the micromorphic curvature tensors $\tilde{\mathcal{K}}, \hat{\mathcal{K}}$ we have

$$\tilde{\mathcal{K}}^* = \tilde{\mathcal{K}} \quad , \quad (12.239)$$

$$\hat{\mathcal{K}}^* = \mathcal{L}(\mathbf{f}_p^*, (\mathbf{f}_p^*)^{T-1}, (\mathbf{f}_p^*)^{T-1})[\tilde{\mathcal{K}}^*] = \mathcal{L}(\mathbf{Q}_p, \mathbf{Q}_p, \mathbf{Q}_p)\mathcal{L}(\mathbf{f}_p, \mathbf{f}_p^{T-1}, \mathbf{f}_p^{T-1})[\tilde{\mathcal{K}}] = \mathcal{L}(\mathbf{Q}_p, \mathbf{Q}_p, \mathbf{Q}_p)[\hat{\mathcal{K}}] \quad . \quad (12.240)$$

In a similar manner, if $\hat{\mathcal{P}}$ represents any one of the tensors $\hat{\mathcal{K}}_e, \hat{\mathcal{K}}_p, \hat{\mathcal{K}}, \hat{\mathcal{K}}_e, \hat{\mathcal{K}}_p$, then

$$\hat{\mathcal{P}}^* = \mathcal{L}(\mathbf{Q}_p, \mathbf{Q}_p, \mathbf{Q}_p)[\hat{\mathcal{P}}] \quad . \quad (12.241)$$

12.5 Conditions for the validity of Il'iushin's postulate

We recall from (12.92)–(12.94) that

$$\tilde{\mathbf{S}} = \varrho \mathcal{R} \frac{\partial \tilde{\Psi}_e}{\partial \tilde{\boldsymbol{\varepsilon}}} \quad , \quad \tilde{\boldsymbol{\sigma}} = \varrho \mathcal{R} \frac{\partial \tilde{\Psi}_e}{\partial \tilde{\boldsymbol{\beta}}} \quad , \quad \tilde{\mathbf{S}} = \varrho \mathcal{R} \frac{\partial \tilde{\Psi}_e}{\partial \tilde{\boldsymbol{\kappa}}} \quad . \quad (12.242)$$

Assume (12.106) to apply and consider a small strain-curvature cycle $ABCD$ (see Fig. 12.1), which is parameterized by time t . Denote by $M^{(X)}$ the value of some quantity M at point X . Then, the times connected with points A, B, C, D are $t^{(A)}, t^{(B)}, t^{(C)}, t^{(D)}$, respectively, ($t^{(A)} < t^{(B)} < t^{(C)} < t^{(D)}$). The strain-curvature cycle begins and ends at $\tilde{\boldsymbol{\varepsilon}} = \tilde{\boldsymbol{\varepsilon}}^{(A)} = \tilde{\boldsymbol{\varepsilon}}^{(D)}$, $\tilde{\boldsymbol{\beta}} = \tilde{\boldsymbol{\beta}}^{(A)} = \tilde{\boldsymbol{\beta}}^{(D)}$, $\tilde{\boldsymbol{\kappa}} = \tilde{\boldsymbol{\kappa}}^{(A)} = \tilde{\boldsymbol{\kappa}}^{(D)}$, while plastic flow occurs only between B and C . In analogy to Lin and Naghdi [108], we use the notation

$$\mathbf{u}(t) := (\tilde{\boldsymbol{\varepsilon}}(t), \tilde{\boldsymbol{\beta}}(t), \tilde{\boldsymbol{\kappa}}(t)) \quad , \quad \mathbf{u}_p(t) := (\tilde{\boldsymbol{\varepsilon}}_p(t), \tilde{\boldsymbol{\beta}}_p(t), \tilde{\boldsymbol{\kappa}}_p(t)) \quad , \quad (12.243)$$

$$\mathbf{u}^{(X)} := (\tilde{\boldsymbol{\varepsilon}}^{(X)}, \tilde{\boldsymbol{\beta}}^{(X)}, \tilde{\boldsymbol{\kappa}}^{(X)}) \quad , \quad \mathbf{u}_p^{(X)} := (\tilde{\boldsymbol{\varepsilon}}_p^{(X)}, \tilde{\boldsymbol{\beta}}_p^{(X)}, \tilde{\boldsymbol{\kappa}}_p^{(X)}) \quad . \quad (12.244)$$

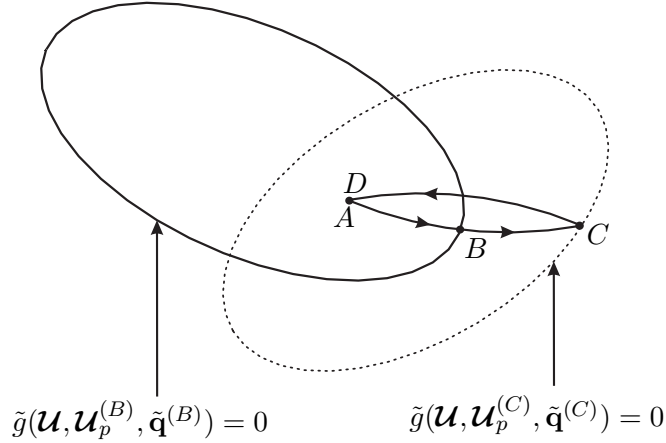

Figure 12.1: A small strain-curvature cycle with plastic flow occurring between B and C only.

Since (12.92)–(12.94), and therefore also (12.242), are assumed to hold during plastic loading as well, we have

$$\begin{aligned} I(t^{(A)}, t^{(D)}) &= \frac{1}{\varrho \mathcal{R}} \int_{t^{(A)}}^{t^{(D)}} \left\{ \tilde{\mathbf{S}} \cdot \dot{\tilde{\boldsymbol{\varepsilon}}} + \tilde{\boldsymbol{\sigma}} \cdot \dot{\tilde{\boldsymbol{\beta}}} + \tilde{\mathbf{S}} \cdot \dot{\tilde{\boldsymbol{\kappa}}} \right\} dt \\ &= \int_{t^{(A)}}^{t^{(D)}} \left\{ \frac{\partial \tilde{\Psi}_e(\mathbf{u}(t), \mathbf{u}_p(t))}{\partial \tilde{\boldsymbol{\varepsilon}}(t)} \cdot \dot{\tilde{\boldsymbol{\varepsilon}}}(t) + \frac{\partial \tilde{\Psi}_e(\mathbf{u}(t), \mathbf{u}_p(t))}{\partial \tilde{\boldsymbol{\beta}}(t)} \cdot \dot{\tilde{\boldsymbol{\beta}}}(t) + \frac{\partial \tilde{\Psi}_e(\mathbf{u}(t), \mathbf{u}_p(t))}{\partial \tilde{\boldsymbol{\kappa}}(t)} \cdot \dot{\tilde{\boldsymbol{\kappa}}}(t) \right\} dt \\ &= \tilde{\Psi}_e(\mathbf{u}^{(A)}, \mathbf{u}_p^{(C)}) - \tilde{\Psi}_e(\mathbf{u}^{(A)}, \mathbf{u}_p^{(B)}) - \int_{t^{(B)}}^{t^{(C)}} \frac{\partial \tilde{\Psi}_e(\mathbf{u}(t), \mathbf{u}_p(t))}{\partial \tilde{\boldsymbol{\varepsilon}}_p(t)} \cdot \dot{\tilde{\boldsymbol{\varepsilon}}}_p(t) dt \\ &\quad - \int_{t^{(B)}}^{t^{(C)}} \frac{\partial \tilde{\Psi}_e(\mathbf{u}(t), \mathbf{u}_p(t))}{\partial \tilde{\boldsymbol{\beta}}_p(t)} \cdot \dot{\tilde{\boldsymbol{\beta}}}_p(t) dt - \int_{t^{(B)}}^{t^{(C)}} \frac{\partial \tilde{\Psi}_e(\mathbf{u}(t), \mathbf{u}_p(t))}{\partial \tilde{\boldsymbol{\kappa}}_p(t)} \cdot \dot{\tilde{\boldsymbol{\kappa}}}_p(t) dt \quad . \quad (12.245) \end{aligned}$$

We make note of the identity

$$\tilde{\Psi}_e(\mathbf{u}^{(A)}, \mathbf{u}^{(C)}) - \tilde{\Psi}_e(\mathbf{u}^{(A)}, \mathbf{u}^{(B)}) =$$

$$= \int_{t^{(B)}}^{t^{(C)}} \left\{ \frac{\partial \tilde{\Psi}_e(\mathbf{u}^{(A)}, \mathbf{u}_p(t))}{\partial \tilde{\epsilon}_p(t)} \cdot \dot{\tilde{\epsilon}}_p(t) + \frac{\partial \tilde{\Psi}_e(\mathbf{u}^{(A)}, \mathbf{u}_p(t))}{\partial \tilde{\beta}_p(t)} \cdot \dot{\tilde{\beta}}_p(t) + \frac{\partial \tilde{\Psi}_e(\mathbf{u}^{(A)}, \mathbf{u}_p(t))}{\partial \tilde{\mathcal{K}}_p(t)} \cdot \dot{\tilde{\mathcal{K}}}_p(t) \right\} dt \quad , \quad (12.246)$$

and conclude from (12.245), (12.106)

$$\begin{aligned} I(t^{(A)}, t^{(D)}) &= \int_{t^{(B)}}^{t^{(C)}} \left[\left\{ \frac{\partial \tilde{\Psi}_e(\mathbf{u}^{(A)}, \mathbf{u}_p(t))}{\partial \tilde{\epsilon}_p(t)} - \frac{\partial \tilde{\Psi}_e(\mathbf{u}(t), \mathbf{u}_p(t))}{\partial \tilde{\epsilon}_p(t)} \right\} \cdot \dot{\tilde{\epsilon}}_p(t) \right. \\ &\quad + \left\{ \frac{\partial \tilde{\Psi}_e(\mathbf{u}^{(A)}, \mathbf{u}_p(t))}{\partial \tilde{\beta}_p(t)} - \frac{\partial \tilde{\Psi}_e(\mathbf{u}(t), \mathbf{u}_p(t))}{\partial \tilde{\beta}_p(t)} \right\} \cdot \dot{\tilde{\beta}}_p(t) \\ &\quad \left. + \left\{ \frac{\partial \tilde{\Psi}_e(\mathbf{u}^{(A)}, \mathbf{u}_p(t))}{\partial \tilde{\mathcal{K}}_p(t)} - \frac{\partial \tilde{\Psi}_e(\mathbf{u}(t), \mathbf{u}_p(t))}{\partial \tilde{\mathcal{K}}_p(t)} \right\} \cdot \dot{\tilde{\mathcal{K}}}_p(t) \right] dt \geq 0 \quad . \end{aligned} \quad (12.247)$$

By using Taylor's theorem

$$\begin{aligned} \lim_{t^{(C)} \rightarrow t^{(B)}} \frac{I(t^{(A)}, t^{(D)})}{t^{(C)} - t^{(B)}} &= \\ &= \left\{ \frac{\partial \tilde{\Psi}_e(\mathbf{u}^{(A)}, \mathbf{u}_p(t))}{\partial \tilde{\epsilon}_p(t)} \cdot \dot{\tilde{\epsilon}}_p(t) - \frac{\partial \tilde{\Psi}_e(\mathbf{u}(t), \mathbf{u}_p(t))}{\partial \tilde{\epsilon}_p(t)} \cdot \dot{\tilde{\epsilon}}_p(t) \right\}_{t=t^{(B)}} \\ &\quad + \left\{ \frac{\partial \tilde{\Psi}_e(\mathbf{u}^{(A)}, \mathbf{u}_p(t))}{\partial \tilde{\beta}_p(t)} \cdot \dot{\tilde{\beta}}_p(t) - \frac{\partial \tilde{\Psi}_e(\mathbf{u}(t), \mathbf{u}_p(t))}{\partial \tilde{\beta}_p(t)} \cdot \dot{\tilde{\beta}}_p(t) \right\}_{t=t^{(B)}} \\ &\quad + \left\{ \frac{\partial \tilde{\Psi}_e(\mathbf{u}^{(A)}, \mathbf{u}_p(t))}{\partial \tilde{\mathcal{K}}_p(t)} \cdot \dot{\tilde{\mathcal{K}}}_p(t) - \frac{\partial \tilde{\Psi}_e(\mathbf{u}(t), \mathbf{u}_p(t))}{\partial \tilde{\mathcal{K}}_p(t)} \cdot \dot{\tilde{\mathcal{K}}}_p(t) \right\}_{t=t^{(B)}} \geq 0 \quad . \end{aligned} \quad (12.248)$$

Since the point B can be chosen arbitrarily on the yield surface, we may drop the index $t^{(B)}$ in the last relation to get, as a necessary condition for (12.106), the inequality

$$\begin{aligned} & - \frac{\partial \tilde{\Psi}_e(\mathbf{u}, \mathbf{u}_p)}{\partial \tilde{\epsilon}_p} \cdot \dot{\tilde{\epsilon}}_p - \frac{\partial \tilde{\Psi}_e(\mathbf{u}, \mathbf{u}_p)}{\partial \tilde{\beta}_p} \cdot \dot{\tilde{\beta}}_p - \frac{\partial \tilde{\Psi}_e(\mathbf{u}, \mathbf{u}_p)}{\partial \tilde{\mathcal{K}}_p} \cdot \dot{\tilde{\mathcal{K}}}_p \\ & \geq - \frac{\partial \tilde{\Psi}_e(\mathbf{u}^{(A)}, \mathbf{u}_p)}{\partial \tilde{\epsilon}_p} \cdot \dot{\tilde{\epsilon}}_p - \frac{\partial \tilde{\Psi}_e(\mathbf{u}^{(A)}, \mathbf{u}_p)}{\partial \tilde{\beta}_p} \cdot \dot{\tilde{\beta}}_p - \frac{\partial \tilde{\Psi}_e(\mathbf{u}^{(A)}, \mathbf{u}_p)}{\partial \tilde{\mathcal{K}}_p} \cdot \dot{\tilde{\mathcal{K}}}_p \quad , \end{aligned} \quad (12.249)$$

where $\mathbf{u} = (\tilde{\epsilon}, \tilde{\beta}, \tilde{\mathcal{K}})$ denotes a strain-curvature state on the yield surface and $\mathbf{u}_p = (\tilde{\epsilon}_p, \tilde{\beta}_p, \tilde{\mathcal{K}}_p)$ are the plastic strain and plastic micromorphic curvature tensors associated with this state. $\mathbf{u}^{(A)} =$

$(\tilde{\boldsymbol{\epsilon}}^{(A)}, \tilde{\boldsymbol{\beta}}^{(A)}, \tilde{\boldsymbol{\kappa}}^{(A)})$ is a strain-curvature state on or inside the yield surface, i.e. $\tilde{\mathbf{g}}(\boldsymbol{u}^{(A)}, \boldsymbol{u}_p, \tilde{\mathbf{q}}) \leq 0$, with the internal state variables $\tilde{\mathbf{q}}$ being associated with the strain-curvature state \boldsymbol{u} .

Conversely, (12.249) is a sufficient condition for (12.106) to hold. This can be verified by taking the integral of (12.249) along a strain-curvature cycle as shown in Fig. 12.1 For (12.249) to remain valid during this strain-curvature cycle, $\boldsymbol{u}^{(A)}$ must always lie in the intersection of all elastic ranges, which in turn implies that the cycle $ABCD$ is small. Then, following the same steps as in (12.245)–(12.247), but in the inverse direction, it is a straightforward matter to arrive at (12.106).

In view of (12.86)–(12.88), one obtains from (12.249)

$$\begin{aligned}
 & \left\{ \left(1 + \hat{\boldsymbol{\epsilon}}_e^T\right) \frac{\partial \hat{\Psi}_e(\hat{\boldsymbol{\epsilon}}_e, \hat{\boldsymbol{\beta}}_e, \hat{\boldsymbol{\kappa}}_e)}{\partial \hat{\boldsymbol{\epsilon}}_e} + \frac{1}{\varrho \mathcal{R}} \hat{\boldsymbol{\eta}} \right\} \cdot \hat{\boldsymbol{\epsilon}}_p \\
 & + \left\{ \left(1 + 2\hat{\boldsymbol{\beta}}_e\right) \frac{\partial \hat{\Psi}_e(\hat{\boldsymbol{\epsilon}}_e, \hat{\boldsymbol{\beta}}_e, \hat{\boldsymbol{\kappa}}_e)}{\partial \hat{\boldsymbol{\beta}}_e} + \frac{1}{\varrho \mathcal{R}} \hat{\boldsymbol{\Lambda}} \right\}_S \cdot \hat{\boldsymbol{\beta}}_p + \frac{\partial \hat{\Psi}_e(\hat{\boldsymbol{\epsilon}}_e, \hat{\boldsymbol{\beta}}_e, \hat{\boldsymbol{\kappa}}_e)}{\partial \hat{\boldsymbol{\kappa}}_e} \cdot \hat{\boldsymbol{\kappa}}_p \\
 \geq & \left\{ \left(1 + (\hat{\boldsymbol{\epsilon}}_e^{(A)})^T\right) \frac{\partial \hat{\Psi}_e(\hat{\boldsymbol{\epsilon}}_e^{(A)}, \hat{\boldsymbol{\beta}}_e^{(A)}, \hat{\boldsymbol{\kappa}}_e^{(A)})}{\partial \hat{\boldsymbol{\epsilon}}_e} + \frac{1}{\varrho \mathcal{R}} \hat{\boldsymbol{\eta}}^{(A)} \right\} \cdot \hat{\boldsymbol{\epsilon}}_p \\
 & + \left\{ \left(1 + 2\hat{\boldsymbol{\beta}}_e^{(A)}\right) \frac{\partial \hat{\Psi}_e(\hat{\boldsymbol{\epsilon}}_e^{(A)}, \hat{\boldsymbol{\beta}}_e^{(A)}, \hat{\boldsymbol{\kappa}}_e^{(A)})}{\partial \hat{\boldsymbol{\beta}}_e} + \frac{1}{\varrho \mathcal{R}} \hat{\boldsymbol{\Lambda}}^{(A)} \right\}_S \cdot \hat{\boldsymbol{\beta}}_p + \frac{\partial \hat{\Psi}_e(\hat{\boldsymbol{\epsilon}}_e^{(A)}, \hat{\boldsymbol{\beta}}_e^{(A)}, \hat{\boldsymbol{\kappa}}_e^{(A)})}{\partial \hat{\boldsymbol{\kappa}}_e} \cdot \hat{\boldsymbol{\kappa}}_p \quad ,
 \end{aligned} \tag{12.250}$$

or, by virtue of (12.96), (12.97), and (12.92)–(12.94),

$$\hat{\mathbf{P}} \cdot \hat{\boldsymbol{\epsilon}}_p + \hat{\boldsymbol{\Pi}} \cdot \hat{\boldsymbol{\beta}}_p + \hat{\mathbf{S}} \cdot \hat{\boldsymbol{\kappa}}_p \geq \hat{\mathbf{P}}^{(A)} \cdot \hat{\boldsymbol{\epsilon}}_p + \hat{\boldsymbol{\Pi}}^{(A)} \cdot \hat{\boldsymbol{\beta}}_p + \hat{\mathbf{S}}^{(A)} \cdot \hat{\boldsymbol{\kappa}}_p \quad . \tag{12.251}$$

Inequality (12.251) is equivalent to (12.250) and therefore equivalent to (12.106).

12.6 Decompositions of strain and micromorphic curvature tensors – dual stress and couple stress tensors

Decomposition of the strain tensors for the microstructure

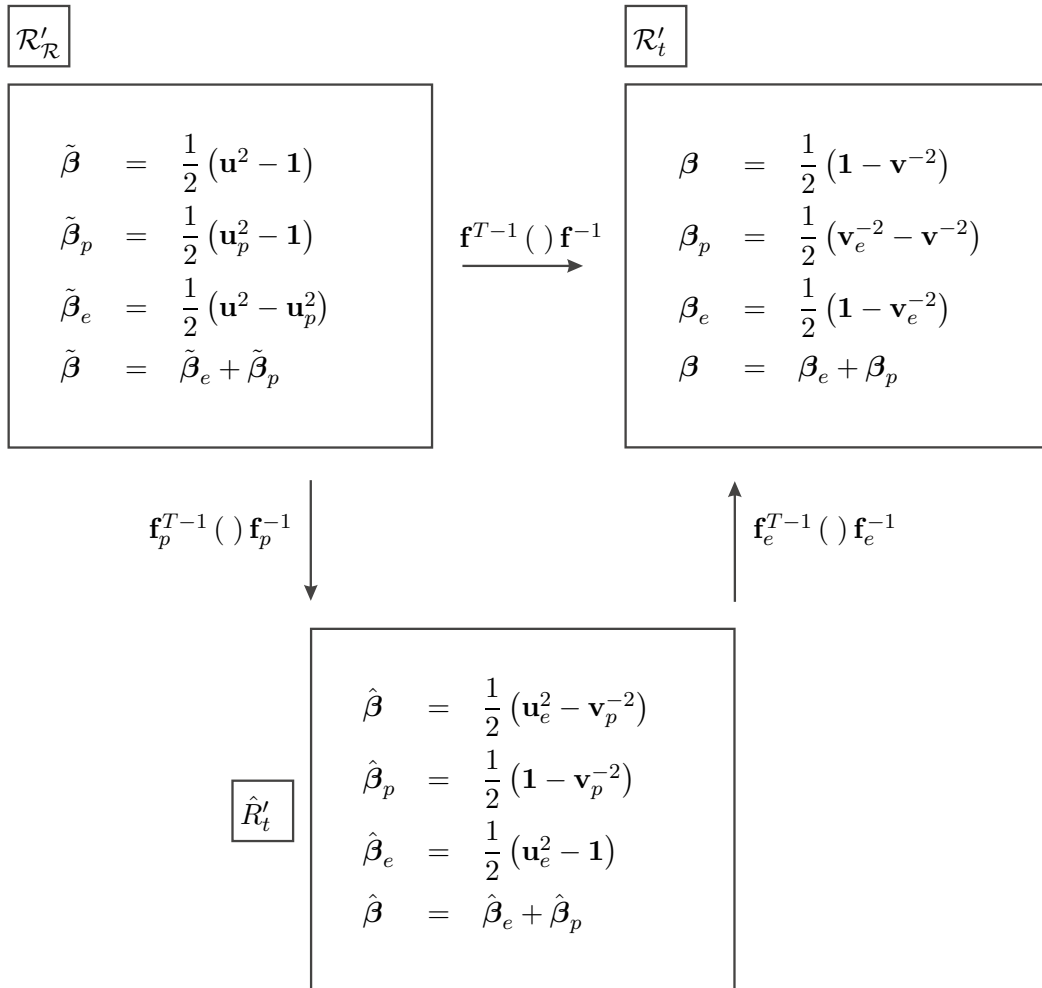

Decomposition of the strain rate tensors for the microstructure

$$\hat{\mathbf{l}}_p = \dot{\mathbf{f}}_p \mathbf{f}_p^{-1} = \hat{\mathbf{d}}_p + \hat{\mathbf{w}}_p, \quad \mathbf{l} = \dot{\mathbf{f}} \mathbf{f}^{-1} = \mathbf{d} + \mathbf{w}$$

$(\cdot)^\cdot$: relative to $\mathcal{R}'_{\mathcal{R}}$

$(\cdot)^\Delta = (\cdot)^\cdot + \hat{\mathbf{l}}_p^T (\cdot) + (\cdot) \hat{\mathbf{l}}_p$: relative to $\hat{\mathcal{R}}'_t$

$(\cdot)^\Delta = (\cdot)^\cdot + \mathbf{l}^T (\cdot) + (\cdot) \mathbf{l}$: relative to \mathcal{R}'_t

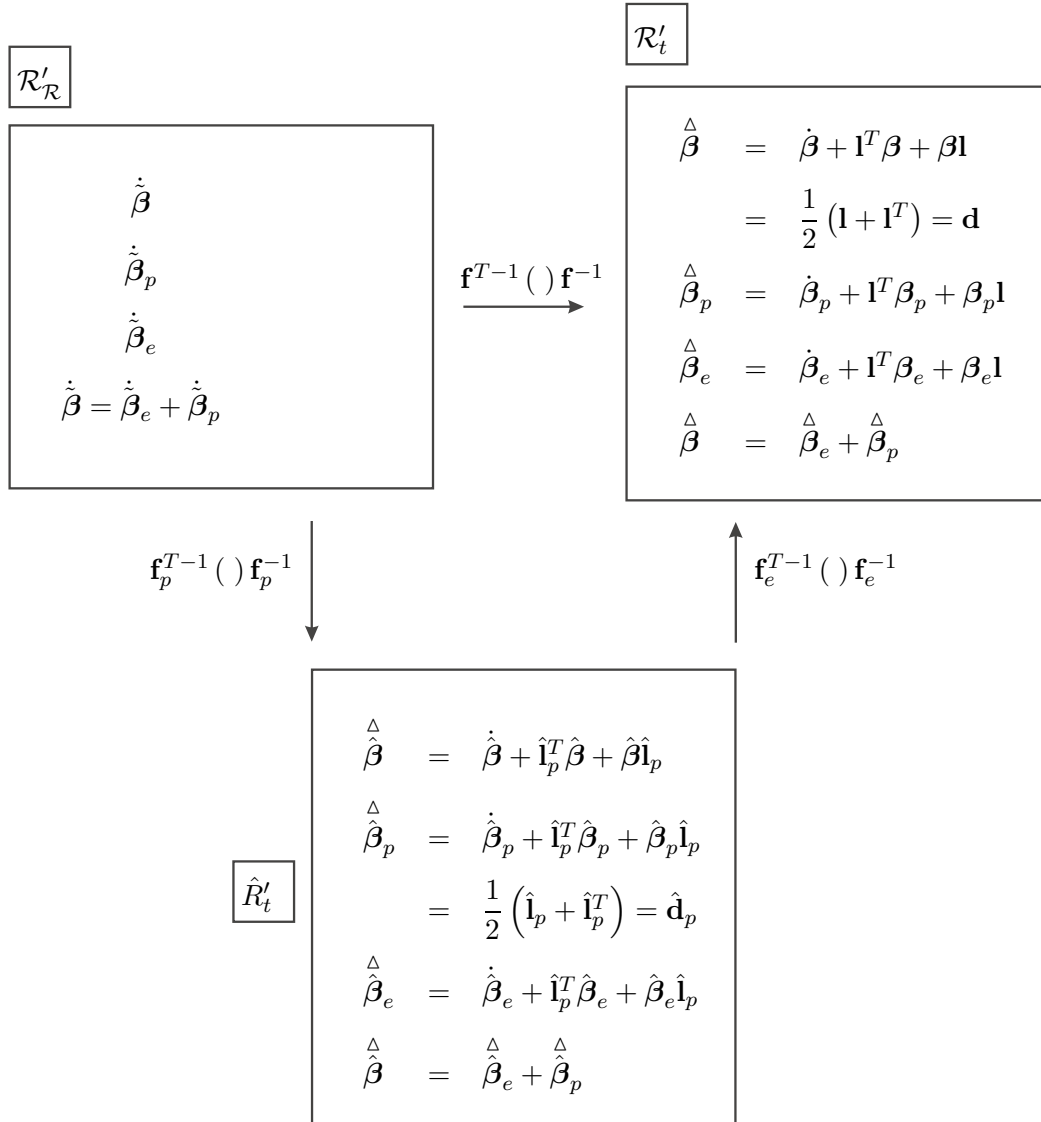

Decomposition of the micromorphic strain tensors

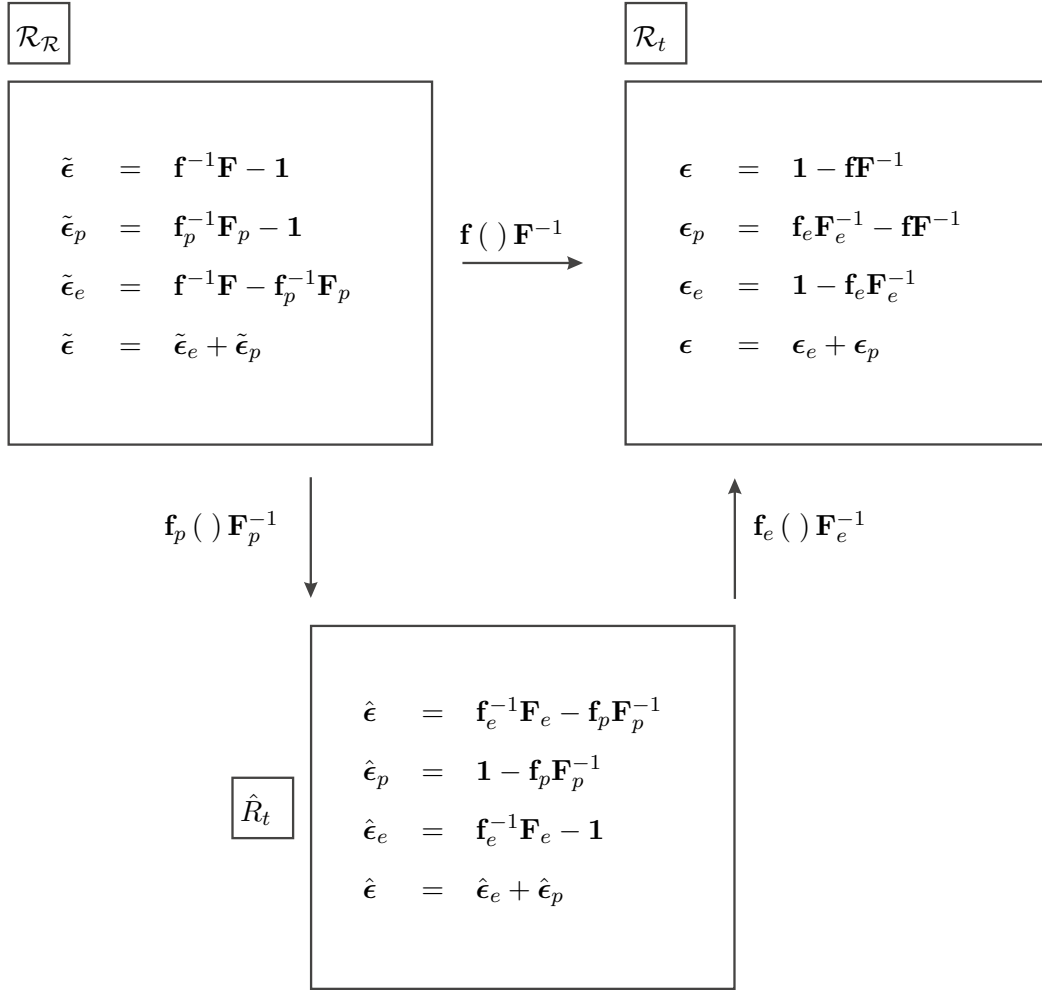

Decomposition of the micromorphic strain rates

$$\hat{\mathbf{L}}_p = \dot{\mathbf{F}}_p \mathbf{F}_p^{-1} = \hat{\mathbf{D}}_p + \hat{\mathbf{W}}_p, \quad \mathbf{L} = \dot{\mathbf{F}} \mathbf{F}^{-1} = \mathbf{D} + \mathbf{W}$$

$(\cdot)^\cdot$: relative to $\mathcal{R}_{\mathcal{R}}$

$(\cdot)^\Delta = (\cdot)^\cdot - \hat{\mathbf{l}}_p(\cdot) + (\cdot)^\cdot \hat{\mathbf{L}}_p$: relative to $\hat{\mathcal{R}}_t$

$(\cdot)^\Delta = (\cdot)^\cdot - \mathbf{l}(\cdot) + (\cdot)^\cdot \mathbf{L}$: relative to \mathcal{R}_t

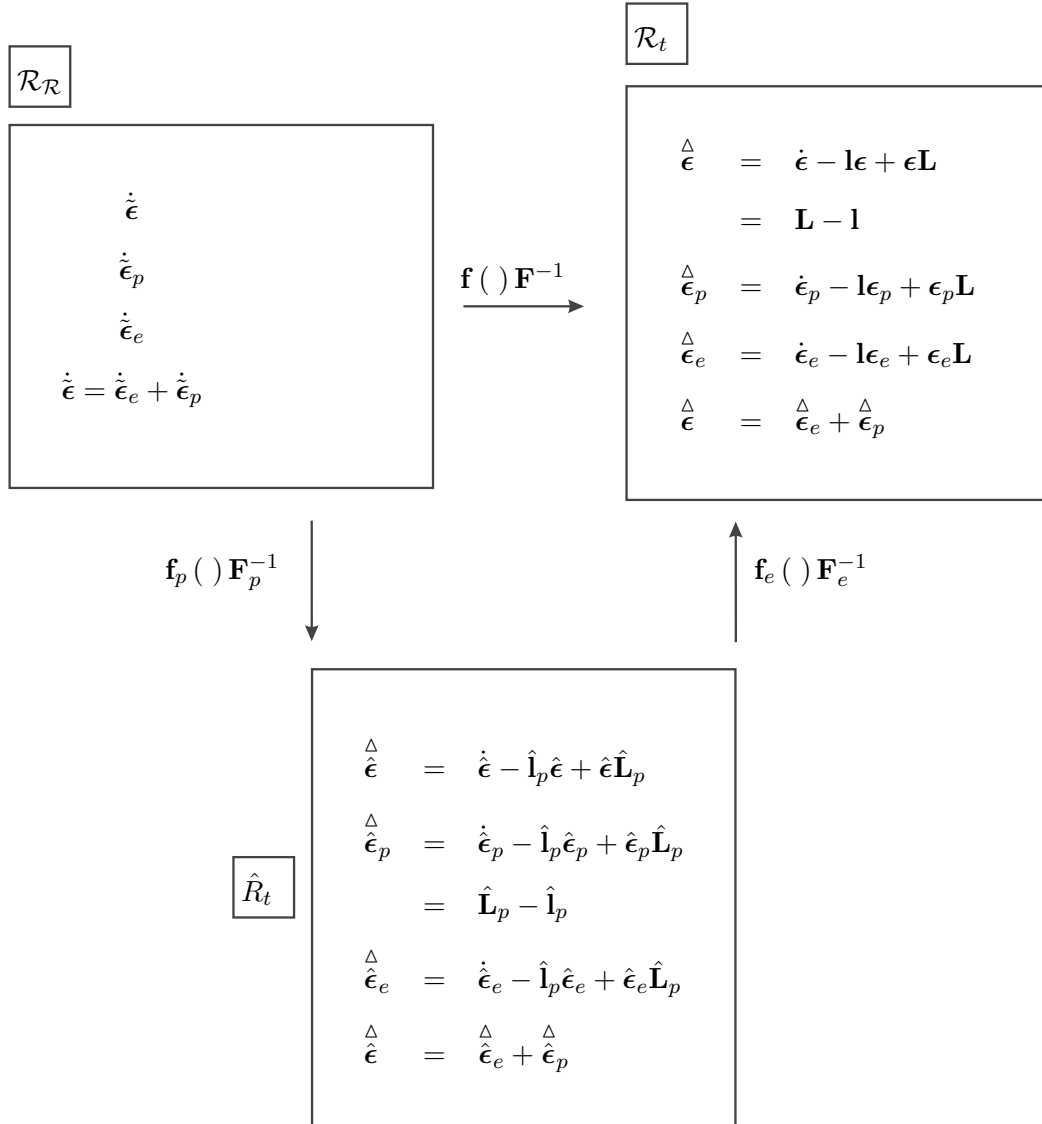

Decomposition of the micromorphic curvature tensors $\tilde{\mathcal{K}}$, $\hat{\mathcal{K}}$, \mathcal{K}

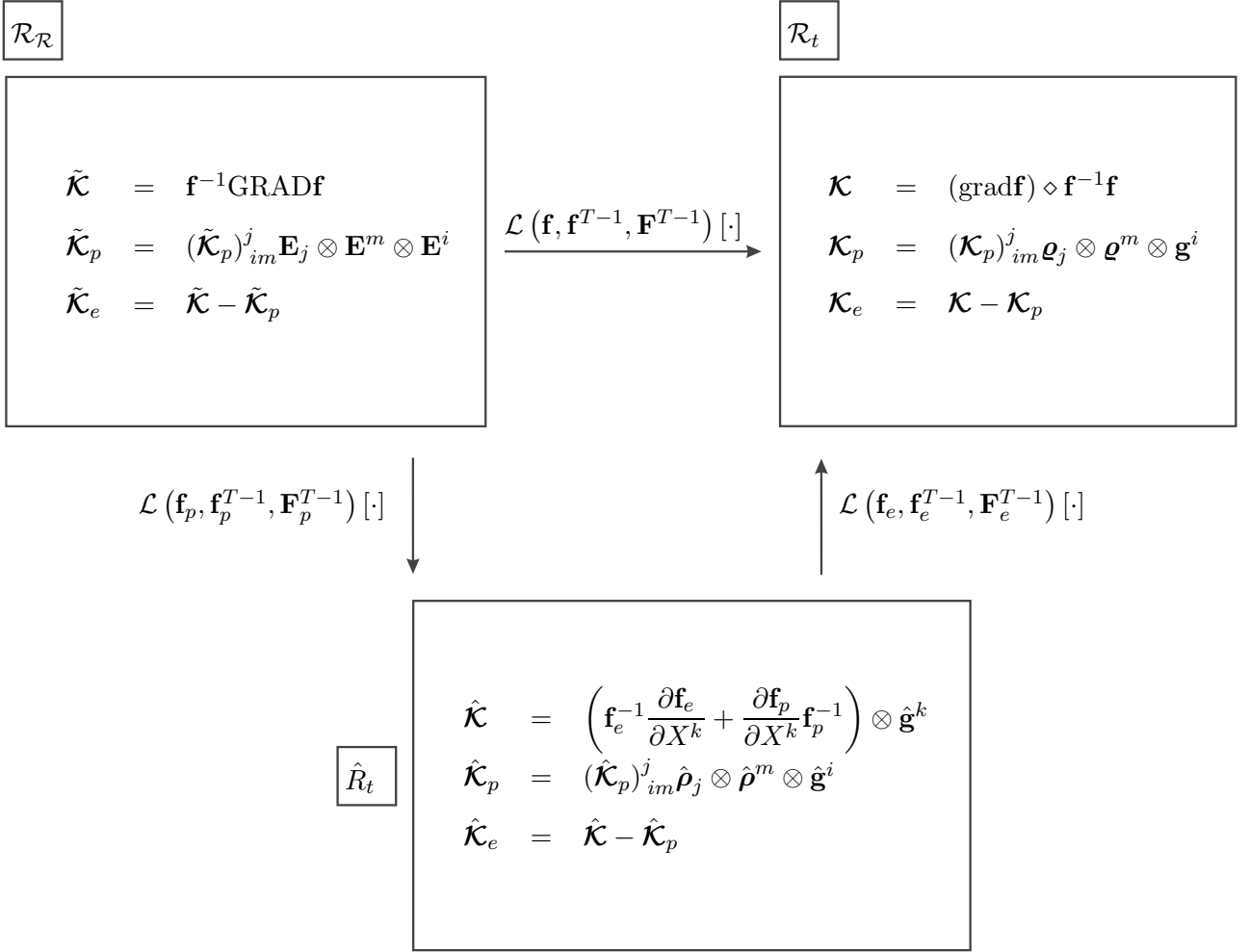

Decomposition of the associated rates for $\tilde{\mathcal{K}}, \hat{\mathcal{K}}, \mathcal{K}$

$(\cdot)^\cdot$: relative to $\mathcal{R}_{\mathcal{R}}$

$(\cdot)^\Delta = (\cdot)^\cdot - \hat{\mathbf{l}}_p(\cdot) + \hat{\mathbf{l}}_p^T \diamond (\cdot) + (\cdot) \hat{\mathbf{L}}_p$: relative to \hat{R}_t

$(\cdot)^\Delta = (\cdot)^\cdot - \mathbf{l}(\cdot) + \mathbf{l}^T \diamond (\cdot) + (\cdot) \mathbf{L}$: relative to \mathcal{R}_t

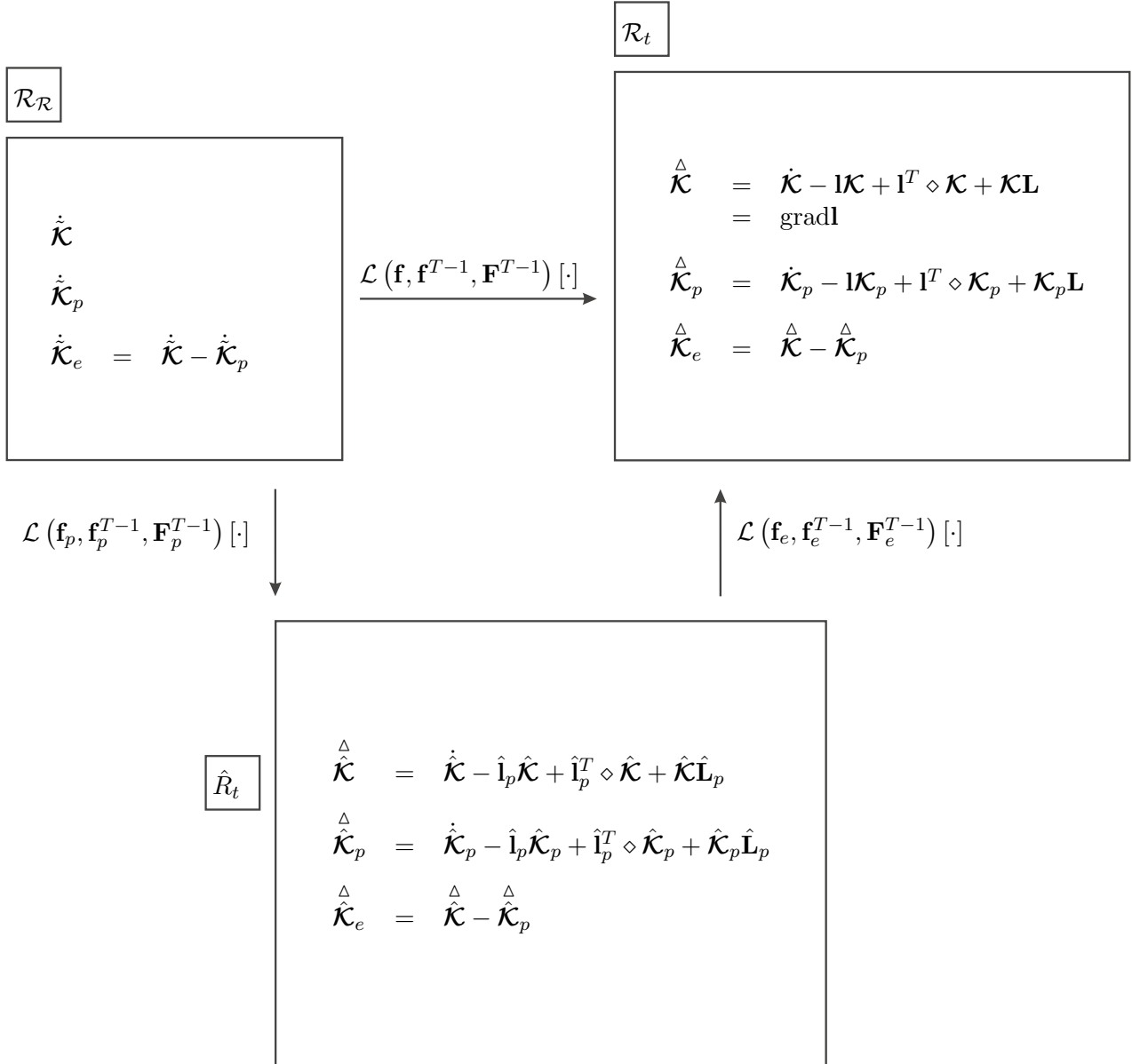

Stress tensors related to the microcontinuum and associated rates

$(\cdot)^\cdot$: relative to $\mathcal{R}_{\mathcal{R}}$

$(\cdot)^\nabla = (\cdot)^\cdot - \hat{\mathbf{l}}_p(\cdot) - (\cdot)\hat{\mathbf{l}}_p^T$: relative to $\hat{\mathcal{R}}_t$

$(\cdot)^\nabla = (\cdot)^\cdot - \mathbf{l}(\cdot) - (\cdot)\mathbf{l}^T$: relative to \mathcal{R}_t

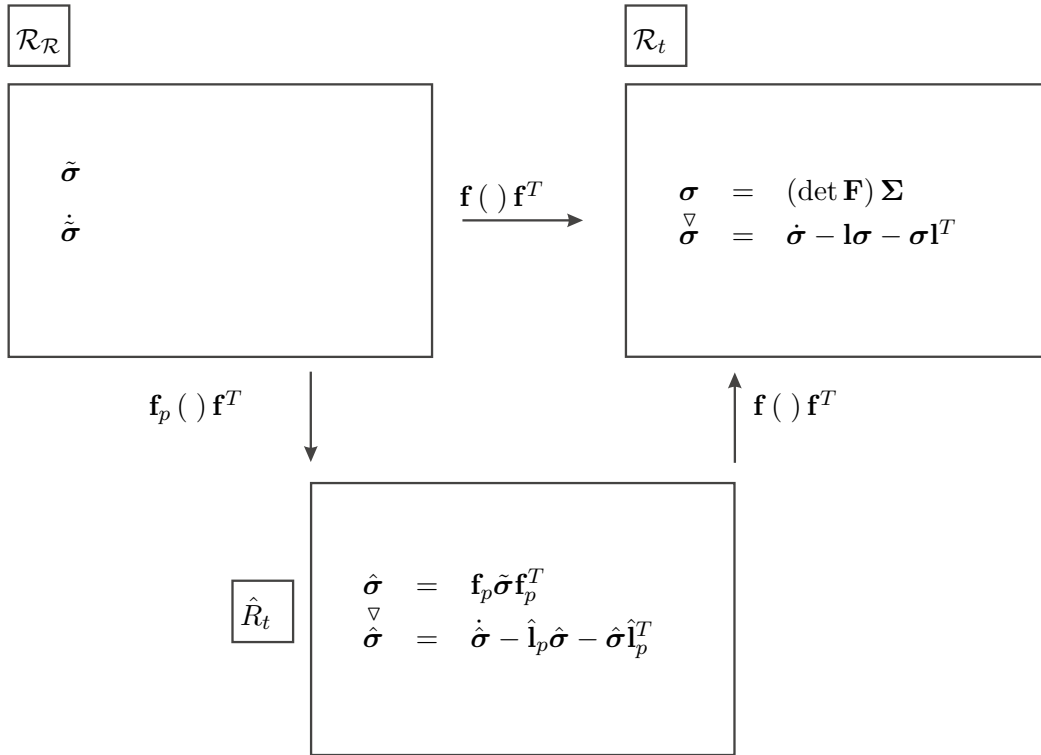

Stress tensors related to the macroscopic continuum and associated rates

$(\cdot)^\cdot$: relative to $\mathcal{R}_{\mathcal{R}}$

$(\cdot)^\nabla = (\cdot)^\cdot + \hat{\mathbf{I}}_p^T (\cdot) - (\cdot) \hat{\mathbf{L}}_p^T$: relative to $\hat{\mathcal{R}}_t$

$(\cdot)^\nabla = (\cdot)^\cdot + \mathbf{I}^T (\cdot) - (\cdot) \mathbf{L}^T$: relative to \mathcal{R}_t

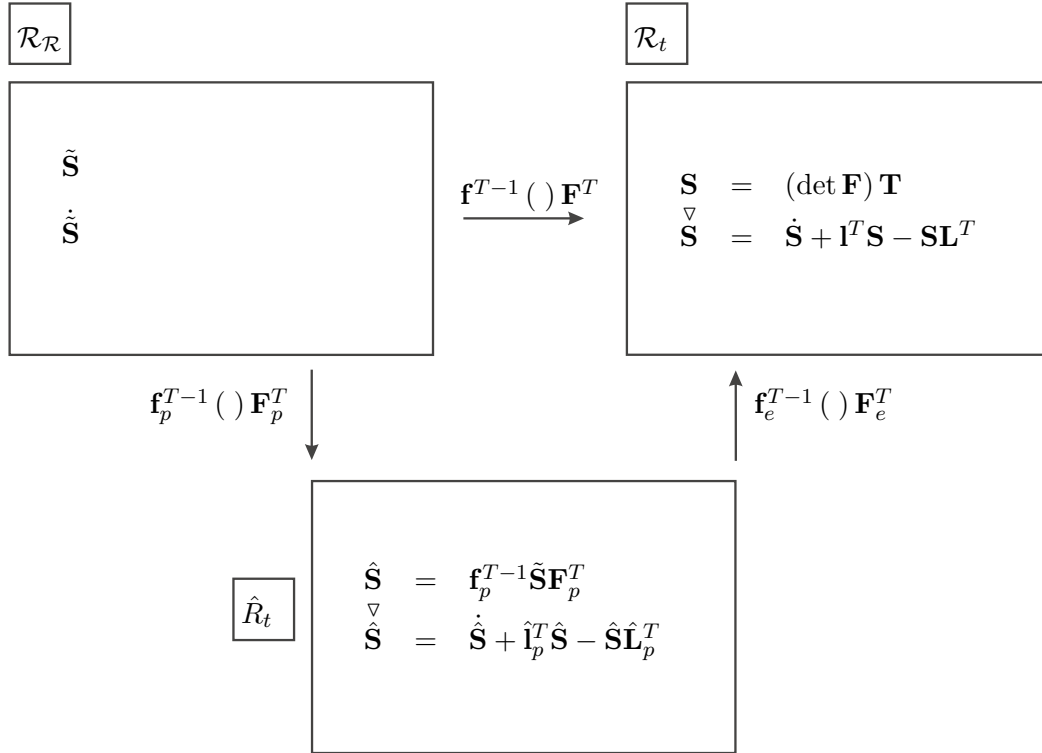

Double stress tensors and associated rates

$(\cdot)^\cdot$: relative to $\mathcal{R}_{\mathcal{R}}$

$(\cdot)^\nabla = (\cdot)^\cdot + \hat{\mathbf{l}}_p^T (\cdot) - (\cdot) \diamond \hat{\mathbf{l}}_p^T - (\cdot) \hat{\mathbf{L}}_p^T$: relative to \hat{R}_t

$(\cdot)^\nabla = (\cdot)^\cdot + \mathbf{l}^T (\cdot) - (\cdot) \diamond \mathbf{l}^T - (\cdot) \mathbf{L}^T$: relative to \mathcal{R}_t

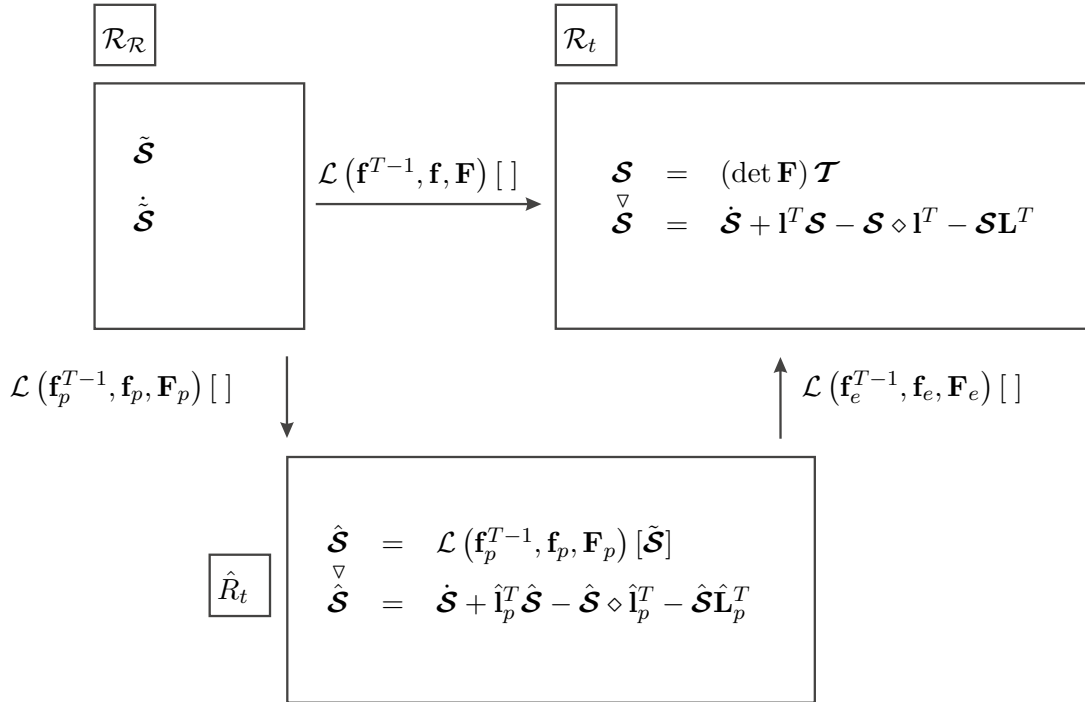

12.7 Kinematic hardening – Decompositions of plastic strain and micromorphic curvature tensors

Kinematic hardening – decomposition of plastic strain tensors for the microstructure

$$\mathbf{f}_p = \mathbf{f}_k \mathbf{f}_d$$

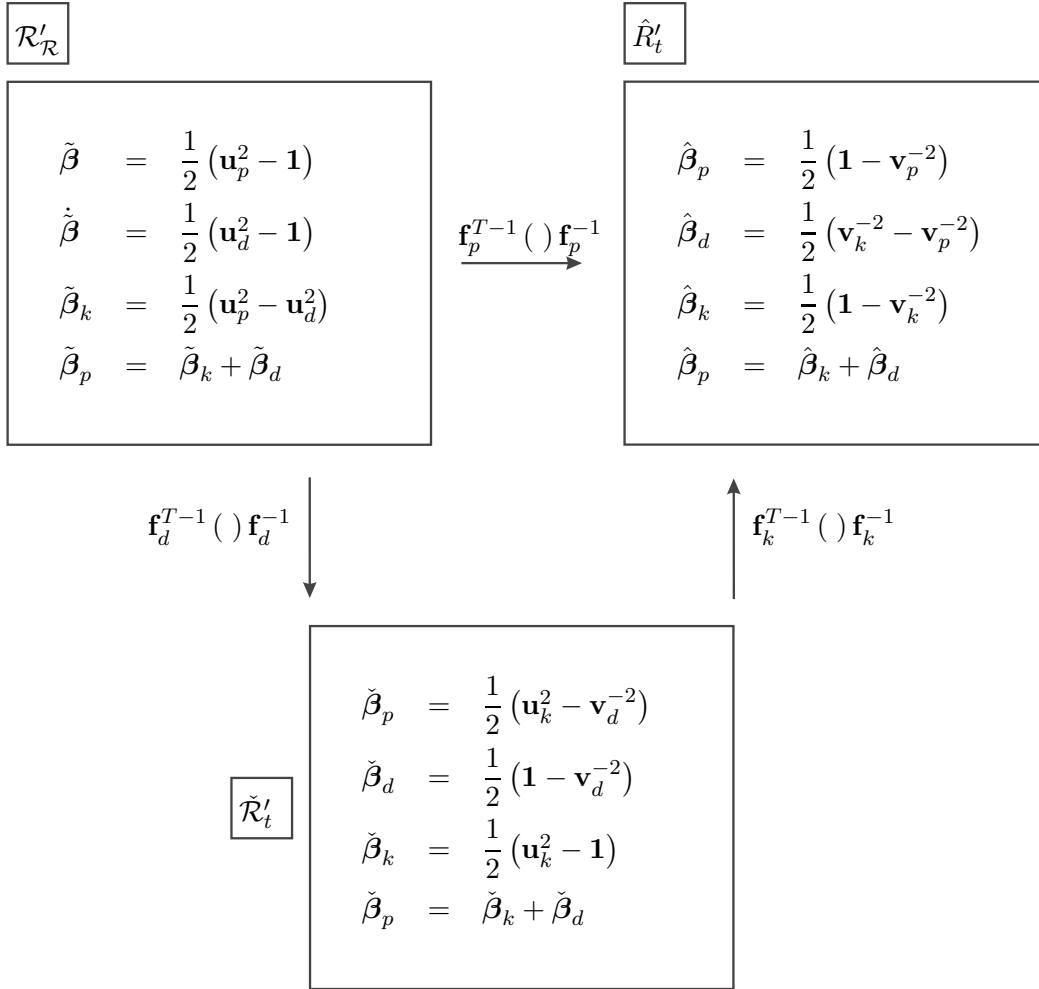

Kinematic hardening – decomposition of plastic strain rate tensors for the microstructure

$$\check{\mathbf{l}}_d = \dot{\mathbf{f}}_d \mathbf{f}_d^{-1}, \quad \hat{\mathbf{l}}_p = \dot{\mathbf{f}}_p \mathbf{f}_p^{-1}$$

$(\cdot)^\cdot$: relative to $\mathcal{R}'_{\mathcal{R}}$

$(\cdot)^\Delta = (\cdot)^\cdot + \check{\mathbf{l}}_d^T (\cdot) + (\cdot) \check{\mathbf{l}}_d$: relative to $\check{\mathcal{R}}'_t$

$(\cdot)^\Delta = (\cdot)^\cdot + \hat{\mathbf{l}}_p^T (\cdot) + (\cdot) \hat{\mathbf{l}}_p$: relative to $\hat{\mathcal{R}}'_t$

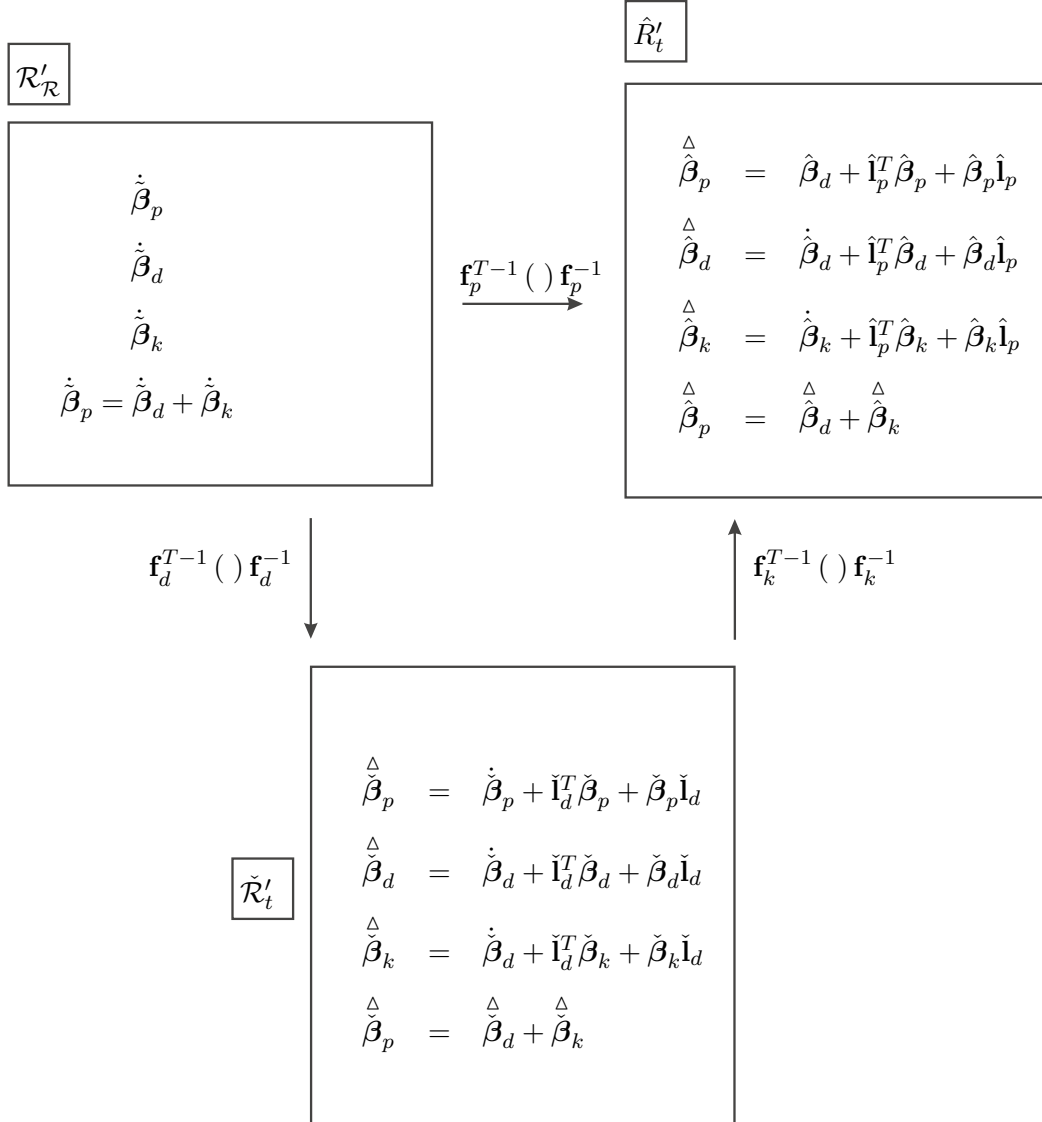

Kinematic hardening – decomposition of plastic strain for the micromorphic continuum

$$\mathbf{F}_p = \mathbf{F}_k \mathbf{F}_d$$

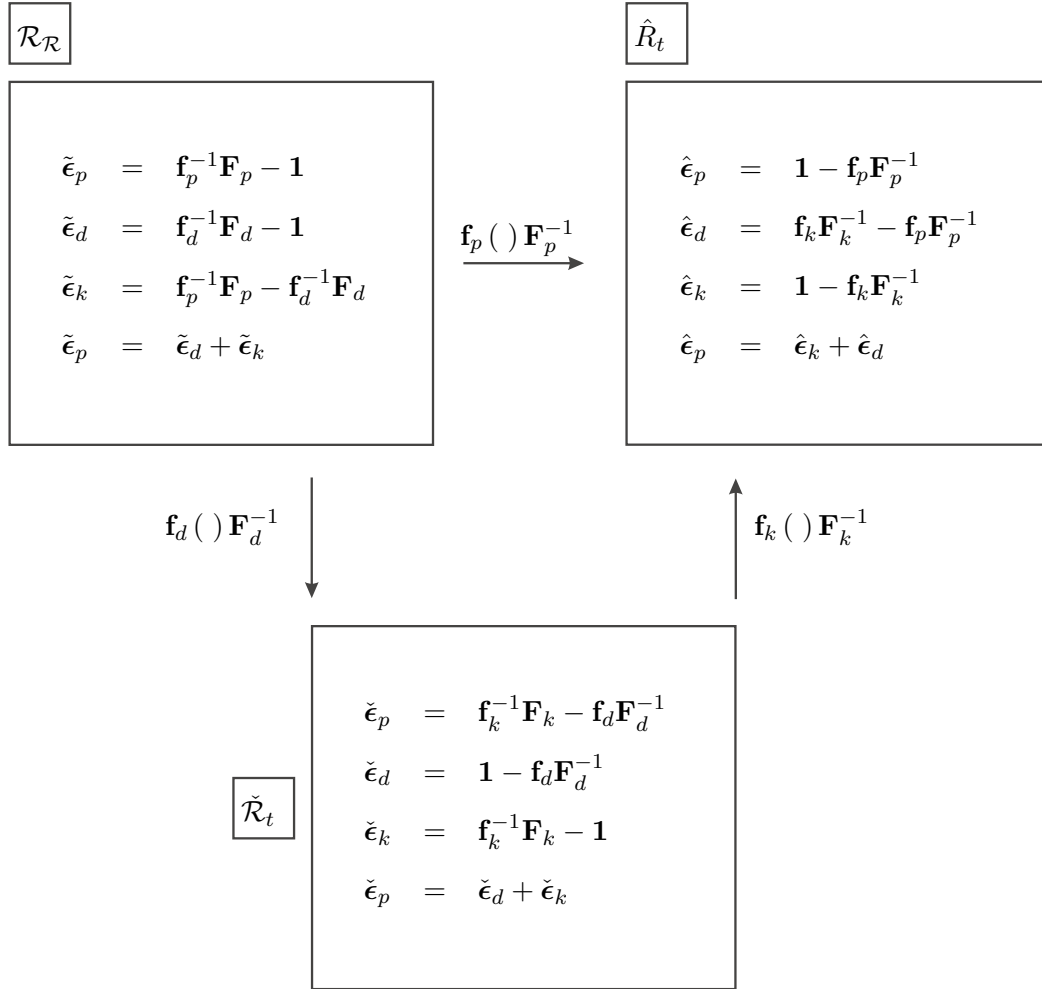

Kinematic hardening – decomposition of plastic strain rates for micromorphic continuum

$$\check{\mathbf{L}}_d = \dot{\mathbf{F}}_d \mathbf{F}_d^{-1}, \quad \check{\mathbf{L}}_p = \dot{\mathbf{F}}_p \mathbf{F}_p^{-1}$$

$(\cdot)^\cdot$: relative to \mathcal{R}_R

$(\cdot)^\Delta = (\cdot)^\cdot - \check{\mathbf{l}}_d (\cdot) + (\cdot) \check{\mathbf{L}}_d$: relative to \hat{R}_t'

$(\cdot)^\Delta = (\cdot)^\cdot - \check{\mathbf{l}}_p (\cdot) + (\cdot) \check{\mathbf{L}}_p$: relative to \hat{R}_t

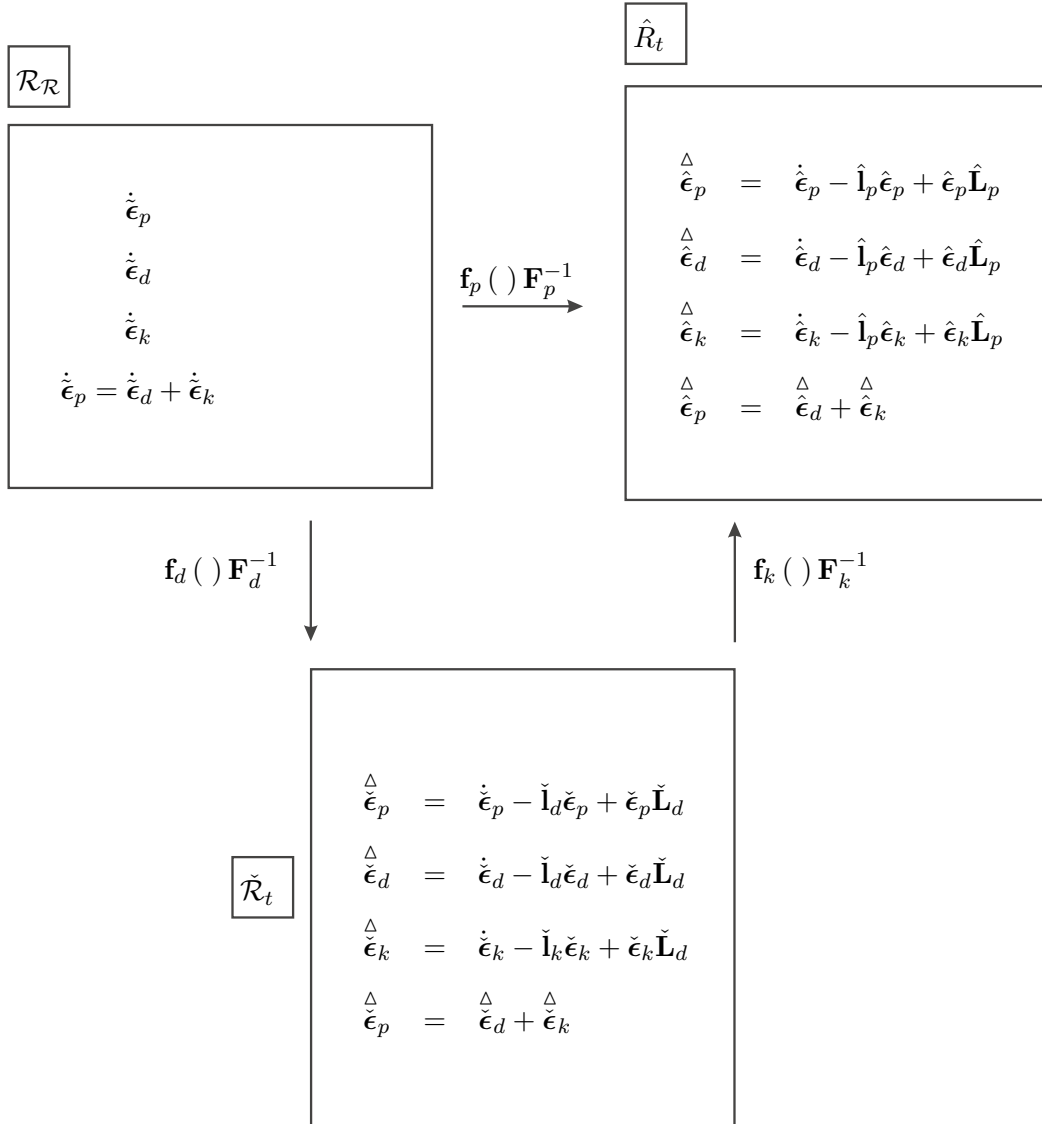

Kinematic hardening – decomposition of plastic micromorphic curvature tensors

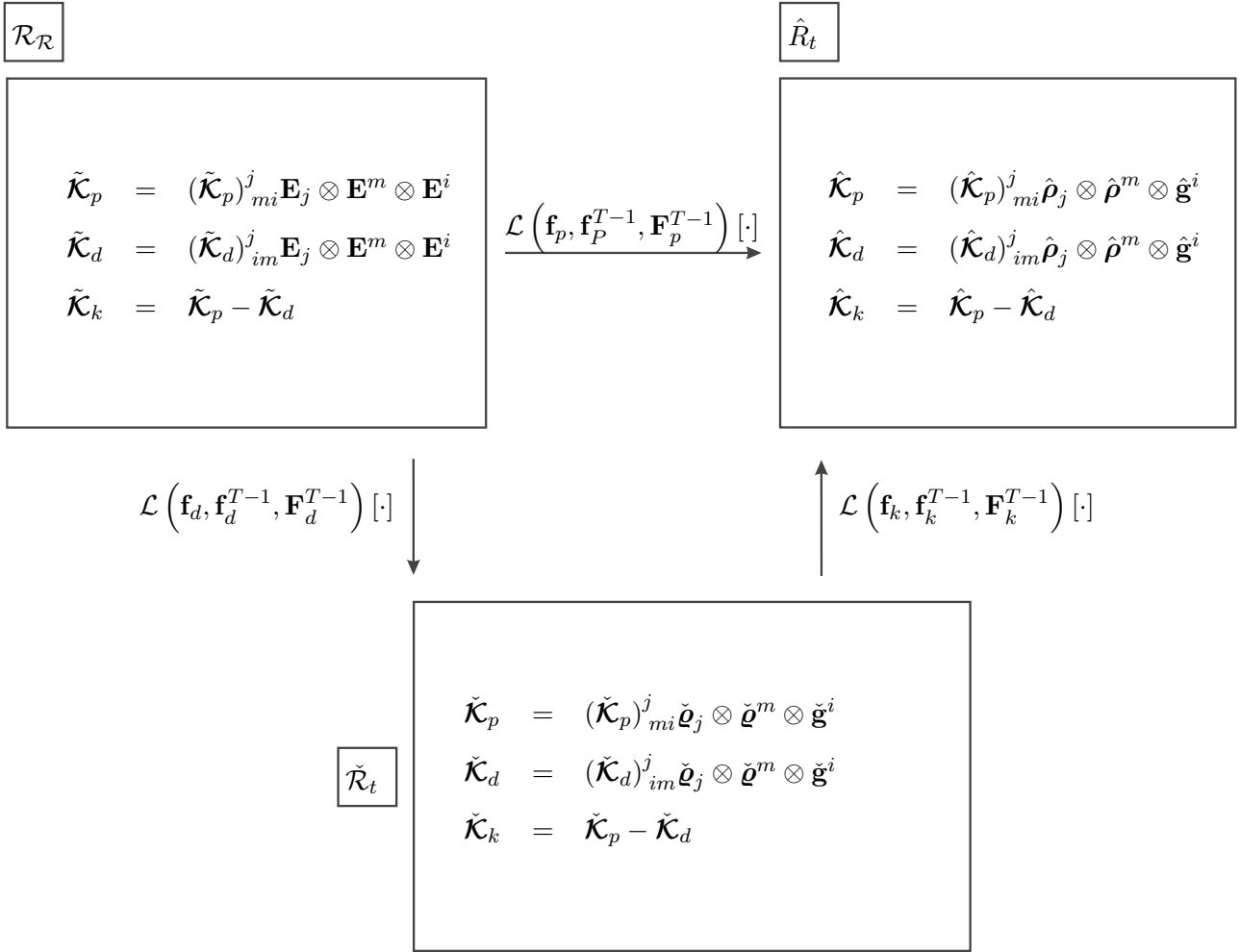

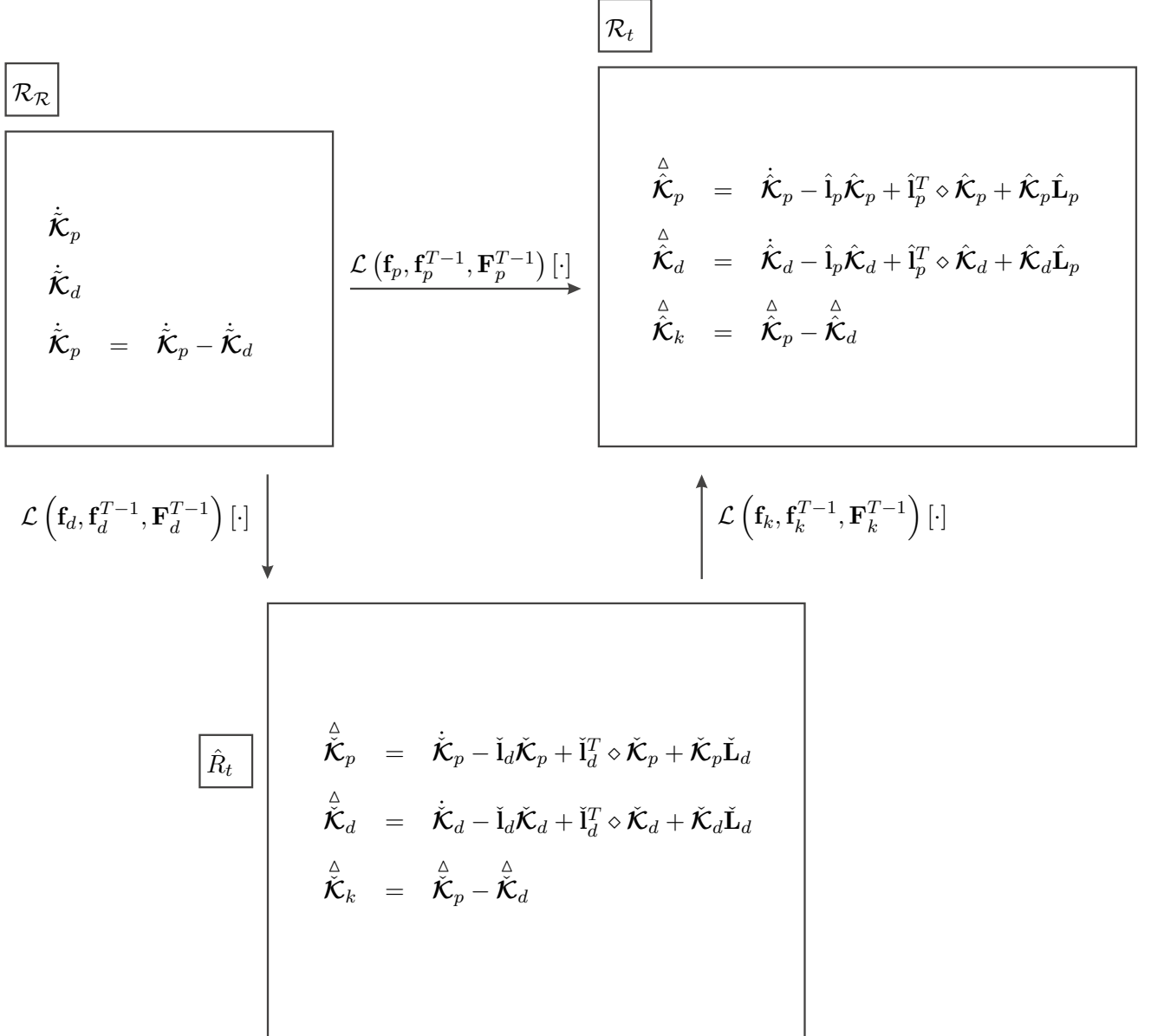
Kinematic hardening – decomposition of plastic micromorphic curvature rates
 $(\cdot)^\cdot$: relative to $\mathcal{R}_{\mathcal{R}}$
 $(\cdot)^\Delta = (\cdot)^\cdot - \check{\mathbf{l}}_d (\cdot) + \check{\mathbf{l}}_d^T \diamond (\cdot) + (\cdot) \check{\mathbf{L}}_d$: relative to $\check{\mathcal{R}}_t$
 $(\cdot)^\Delta = (\cdot)^\cdot - \hat{\mathbf{l}}_p (\cdot) + \hat{\mathbf{l}}_p^T \diamond (\cdot) + (\cdot) \hat{\mathbf{L}}_p$: relative to $\hat{\mathcal{R}}_t$

13 Micromorphic continuum. Part III: Small deformation plasticity coupled with damage

P. Grammenoudis, D. Hofer, Ch. Tsakmakis

**International Journal of Non-Linear Mechanics
accepted for publication**

Micromorphic continuum.
Part III: Small deformation plasticity coupled with damage

P. Grammenoudis^{*}, D. Hofer[°], Ch. Tsakmakis^{*}

^{*}Darmstadt University of Technology, Institute of Continuum Mechanics,
Hochschulstraße 1, 64289 Darmstadt, Germany

[°]Westinghouse Electric Germany GmbH, Abt. PEM,
Dudenstr. 44, 68167 Mannheim, Germany

Abstract

Properties of the micromorphic theory proposed in Part II are discussed for the case of small deformations. Model responses for beam specimens under bending loading and plates with circular holes under tension loading are calculated by employing the finite element method. Some details of the implementation of the theory into the finite element code ABAQUS are outlined in the article. The results reported are concerned with the capabilities of the theory to predict size effects.

13.1 Introduction

A finite deformation micromorphic plasticity theory, exhibiting isotropic and kinematic hardening, and incorporating damage effects, has been proposed in Part II. The theory is consistent with the second law of thermodynamics and deals with a plastic micromorphic curvature tensor, which is not required to fulfill some compatibility conditions, i.e. it is not related to some gradient terms. Furthermore, a measure of smallness ε has been introduced in Part II, and the theory has been defined to be of small deformations, if terms only up to order $O(\varepsilon)$ are retained. It is a straightforward task to verify that the small deformation version of the micromorphic model proposed, reads as follows (we confine attention to static balance equations and omit the body and double body forces).

Equilibrium equations

$$\frac{\partial T_{ij}}{\partial X_j} = 0 \quad \text{in } \mathcal{R}_{\mathcal{R}} \quad , \quad (13.1)$$

$$\frac{\partial \mathcal{T}_{ijk}}{\partial X_k} + T_{ij} - \Sigma_{ij} = 0 \quad \text{in } \mathcal{R}_{\mathcal{R}} \quad . \quad (13.2)$$

Boundary conditions

$$T_{ij}n_j = \bar{t}_i \quad \text{on } \partial\mathcal{R}_{\mathcal{R}}^{t_i} = \partial\mathcal{R}_{\mathcal{R}} \setminus \partial\mathcal{R}_{\mathcal{R}}^{u_i} \quad , \quad (13.3)$$

$$\mathcal{T}_{ijk}n_k = \bar{t}_{ij}^{(d)} \quad \text{on } \partial\mathcal{R}_{\mathcal{R}}^{t_{ij}^{(d)}} = \partial\mathcal{R}_{\mathcal{R}} \setminus \partial\mathcal{R}_{\mathcal{R}}^{h_{ij}} \quad , \quad (13.4)$$

$$u_i = \bar{u}_i \quad \text{on } \partial\mathcal{R}_{\mathcal{R}}^{u_i} \quad , \quad (13.5)$$

$$h_{ij} = \bar{h}_{ij} \quad \text{on } \partial\mathcal{R}_{\mathcal{R}}^{h_{ij}} \quad . \quad (13.6)$$

Kinematics

$$H_{ij} = \frac{\partial u_i}{\partial X_j} \quad , \quad (13.7)$$

$$\beta_{ij} = \frac{1}{2}(h_{ij} + h_{ji}) \quad , \quad \epsilon_{ij} = H_{ij} - h_{ij} \quad , \quad \mathcal{K}_{ijk} = \frac{\partial h_{ij}}{\partial X_k} \quad , \quad (13.8)$$

$$\beta_{ij} = (\beta_e)_{ij} + (\beta_p)_{ij} \quad , \quad \epsilon_{ij} = (\epsilon_e)_{ij} + (\epsilon_p)_{ij} \quad , \quad \mathcal{K}_{ijk} = (\mathcal{K}_e)_{ijk} + (\mathcal{K}_p)_{ijk} \quad . \quad (13.9)$$

Specific free energy

$$\Psi = \Psi_e + \Psi_{is} + \Psi_k \quad . \quad (13.10)$$

Elasticity laws

$$\begin{aligned} \varrho\Psi_e = & (1-D) \left\{ \frac{1}{2}(\mathbf{A}_e)_{ijpq}(\epsilon_e)_{ij}(\epsilon_e)_{pq} + \frac{1}{2}(\mathbf{B}_e)_{ijpq}(\beta_e)_{ij}(\beta_e)_{pq} \right. \\ & \left. + (\mathbf{D}_e)_{ijpq}(\epsilon_e)_{ij}(\beta_e)_{pq} + \frac{1}{2}(\mathbf{C}_e)_{ijkpqr}(\mathcal{K}_e)_{ijk}(\mathcal{K}_e)_{pqr} \right\} \quad , \end{aligned} \quad (13.11)$$

$$\Sigma_{ij} = \varrho \frac{\partial \Psi_e}{\partial (\beta_e)_{ij}} = (1-D) \{ (\mathbf{B}_e)_{ijpq}(\beta_e)_{pq} + (\mathbf{D}_e)_{ijpq}(\epsilon_e)_{pq} \} \quad , \quad (13.12)$$

$$T_{ij} = \varrho \frac{\partial \Psi_e}{\partial (\epsilon_e)_{ij}} = (1-D) \{ (\mathbf{A}_e)_{ijpq}(\epsilon_e)_{pq} + (\mathbf{D}_e)_{ijpq}(\beta_e)_{pq} \} \quad , \quad (13.13)$$

$$\mathcal{T}_{ijk} = \varrho \frac{\partial \Psi_e}{\partial (\mathcal{K}_e)_{ijk}} = (1-D) (\mathbf{C}_e)_{ijkpqr} (\mathcal{K}_e)_{pqr} \quad . \quad (13.14)$$

Yield function

$$\begin{aligned} f = & \frac{1}{1-D} \left((T_{ij} - T_{ij}^k)^D (\mathbf{A}_y)_{ijpq} (T_{pq} - T_{pq}^k)^D + (\Sigma_{ij} - \Sigma_{ij}^k)^D (\mathbf{B}_y)_{ijpq} (\Sigma_{pq} - \Sigma_{pq}^k)^D \right. \\ & \left. + (\mathcal{T}_{ijk} - \mathcal{T}_{ijk}^k)^D (\mathbf{C}_y)_{ijkpqr} (\mathcal{T}_{pqr} - \mathcal{T}_{pqr}^k)^D \right)^{-\frac{1}{2}} - \frac{R}{1-D} - \bar{k}_0 \quad , \end{aligned} \quad (13.15)$$

$$k := \frac{R}{1-D} + \bar{k}_0 \quad , \quad k := R_0 + \bar{k}_0 \quad . \quad (13.16)$$

Flow rule

$$(\dot{\epsilon}_p)_{ij} = \frac{\dot{s}}{\zeta} \frac{\partial f}{\partial T_{ij}} \quad , \quad (\dot{\beta}_p)_{ij} = \frac{\dot{s}}{\zeta} \frac{\partial f}{\partial \Sigma_{ij}} \quad , \quad (\dot{\mathcal{K}}_p)_{ijk} = \frac{\dot{s}}{\zeta} \frac{\partial f}{\partial \mathcal{T}_{ijk}} \quad , \quad (13.17)$$

$$\zeta := \sqrt{\frac{\partial f}{\partial T_{ij}} \frac{\partial f}{\partial T_{ij}} + \frac{\partial f}{\partial \Sigma_{ij}} \frac{\partial f}{\partial \Sigma_{ij}} + \frac{\partial f}{\partial \mathcal{T}_{ijk}} \frac{\partial f}{\partial \mathcal{T}_{ijk}}} \quad . \quad (13.18)$$

Plasticity

$$L(t) := [\dot{f}(t)]_{s=\text{const.}} \quad (13.19)$$

$$\dot{s} \begin{cases} > 0 & \text{for } f = 0 \ \& \ L > 0 \\ = 0 & \text{otherwise} \end{cases} , \quad (13.20)$$

$$\dot{s} : \text{ to be determined from consistency condition } \dot{f} = 0 . \quad (13.21)$$

Viscoplasticity

$$\dot{s} := \frac{\langle f \rangle^m}{\eta} \geq 0 , \quad (13.22)$$

$$\langle f \rangle : \text{ overstress} . \quad (13.23)$$

Isotropic hardening

$$\varrho \Psi_{is} = (1 - D) \frac{\gamma}{2} (r^2 + 2r_0 r) , \quad (13.24)$$

$$R = \varrho \frac{\partial \Psi_{is}}{\partial r} = (1 - D) \gamma (r + r_0) = (1 - D) (\gamma r + R_0) , \quad (13.25)$$

$$\dot{r} = (1 - \beta r) \frac{\dot{s}}{\zeta} . \quad (13.26)$$

Kinematic hardening

$$\varrho \Psi_k = (1 - D) \left\{ \frac{1}{2} (\mathbf{A}_k)_{ijpq} (\boldsymbol{\epsilon}_k)_{ij} (\boldsymbol{\epsilon}_k)_{pq} + \frac{1}{2} (\mathbf{B}_k)_{ijpq} (\boldsymbol{\beta}_k)_{ij} (\boldsymbol{\beta}_k)_{pq} \right. \\ \left. + (\mathbf{D}_k)_{ijpq} (\boldsymbol{\epsilon}_k)_{ij} (\boldsymbol{\beta}_k)_{pq} + \frac{1}{2} (\mathbf{C}_k)_{ijpqr} (\boldsymbol{\kappa}_k)_{ijk} (\boldsymbol{\kappa}_k)_{pqr} \right\} , \quad (13.27)$$

$$(\boldsymbol{\Sigma}_k)_{ij} = \varrho \frac{\partial \Psi_k}{\partial (\boldsymbol{\beta}_k)_{ij}} = (1 - D) \{ (\mathbf{B}_k)_{ijpq} (\boldsymbol{\beta}_k)_{pq} + (\mathbf{D}_k)_{ijpq} (\boldsymbol{\epsilon}_k)_{pq} \} , \quad (13.28)$$

$$(\mathbf{T}_k)_{ij} = \varrho \frac{\partial \Psi_k}{\partial (\boldsymbol{\epsilon}_k)_{ij}} = (1 - D) \{ (\mathbf{A}_k)_{ijpq} (\boldsymbol{\epsilon}_k)_{pq} + (\mathbf{D}_k)_{ijpq} (\boldsymbol{\beta}_k)_{pq} \} , \quad (13.29)$$

$$(\boldsymbol{\mathcal{T}}_k)_{ijk} = \varrho \frac{\partial \Psi_k}{\partial (\boldsymbol{\kappa}_k)_{ijk}} = (1 - D) (\mathbf{C}_k)_{ijkpqr} (\boldsymbol{\kappa}_k)_{pqr} , \quad (13.30)$$

$$\dot{\boldsymbol{\epsilon}}_k = \dot{\boldsymbol{\epsilon}}_p - \frac{\dot{s}}{1 - D} \{ M_1^k (\text{tr} \mathbf{T}_k) \mathbf{1} + M_2^k \mathbf{T}_k + M_3^k (\mathbf{T}_k)^T \} , \quad (13.31)$$

$$\dot{\boldsymbol{\beta}}_k = \dot{\boldsymbol{\beta}}_p - \frac{\dot{s}}{1 - D} \{ N_1^k (\text{tr} \boldsymbol{\Sigma}_k) \mathbf{1} + 2N_2^k \boldsymbol{\Sigma}_k \} , \quad (13.32)$$

$$\dot{\boldsymbol{\kappa}}_k = \dot{\boldsymbol{\kappa}}_p - \frac{\dot{s}}{1 - D} \hat{\mathcal{P}}_k[\boldsymbol{\mathcal{T}}] . \quad (13.33)$$

Evolution law for damage

$$\dot{D} = -\alpha_1 \dot{s} \varrho \frac{\partial \Psi}{\partial D} . \quad (13.34)$$

The aim of the present paper is to implement this model into the finite element code ABAQUS and to demonstrate its capabilities in describing size effects present in bending of beam specimens and in plates with a hole under tension loading. It should be remarked that Part I and II made it clear, that micromorphic constitutive theories are very complex and include a large number of material

parameters. Therefore, we decided to make transparent capabilities of such theories only for small deformations, excluding from considerations geometrical nonlinearities. Also, several material parameters will be assumed to vanish, in order to reduce the effort of the analysis. Of course, this implies that important capabilities of the model may be not activated. However, the present investigation is not entitled to be complete and will be of qualitative character only. This also concerns the isotropic hardening rule. In fact, isotropic hardening effects due to strains and micromorphic curvature tensors are captured in a unified manner. There are, however, possibilities to account for isotropic hardening effects due to strain and micromorphic curvature effects separately. Such isotropic hardening rules have been elaborated by Grammenoudis and Tsakmakis [72] in micropolar plasticity and are not pursued here.

13.2 Finite element implementation

13.2.1 Weak form of equilibrium equations

Let δu_i be variation of macroscopic displacement and δh_{ij} variation of microscopic displacement gradient. (As usually, δu_i and δh_{ij} have to satisfy homogeneous boundary conditions on $\partial\mathcal{R}_{\mathcal{R}}^{u_i}$ and $\partial\mathcal{R}_{\mathcal{R}}^{h_{ij}}$, respectively.) After taking the scalar product of (13.1) with δu_i , and of (13.2) with δh_{ij} , and integrating over $\mathcal{R}_{\mathcal{R}}$,

$$\mathcal{F}_L := \int_{\mathcal{R}_{\mathcal{R}}} \frac{\partial T_{ij}}{\partial X_j} \delta u_i dV \equiv \int_{\mathcal{R}_{\mathcal{R}}} \operatorname{div} \mathbf{T} \cdot \delta \mathbf{u} dV = 0 \quad , \quad (13.35)$$

$$\mathcal{F}_A := \int_{\mathcal{R}_{\mathcal{R}}} \left(\frac{\partial \mathcal{T}_{ijk}}{\partial X_k} + T_{ij} - \Sigma_{ij} \right) \delta h_{ij} dV = 0 \quad , \quad (13.36)$$

where the suppersuffix L and A stand for linear and angular moment, respectively. As in classical theories, we make use of partial integration and divergence theorem to get the weak form of the equilibrium equations,

$$\mathcal{F}_L := \int_{\partial\mathcal{R}_{\mathcal{R}}^{\bar{\mathbf{t}}}} \bar{\mathbf{t}} \cdot \delta \mathbf{u} dA - \int_{\mathcal{R}_{\mathcal{R}}} \mathbf{T} \cdot \frac{\partial \delta \mathbf{u}}{\partial \mathbf{X}} dV = 0 \quad , \quad (13.37)$$

$$\begin{aligned} \mathcal{F}_A &:= \int_{\partial\mathcal{R}_{\mathcal{R}}^{\bar{\mathbf{t}}^{(d)}}} (\bar{\mathbf{t}}^{(d)})_{ij} \delta h_{ij} dA - \int_{\mathcal{R}_{\mathcal{R}}} \mathcal{T}_{ijk} \frac{\partial \delta h_{ij}}{\partial X_k} dV + \int_{\mathcal{R}_{\mathcal{R}}} (T_{ij} - \Sigma_{ij}) \delta h_{ij} dV \\ &= \int_{\partial\mathcal{R}_{\mathcal{R}}^{\bar{\mathbf{t}}^{(d)}}} \bar{\mathbf{t}}^{(d)} \cdot \delta \mathbf{h} dA - \int_{\mathcal{R}_{\mathcal{R}}} \mathcal{T} \cdot \frac{\partial \delta \mathbf{h}}{\partial \mathbf{X}} dV + \int_{\mathcal{R}_{\mathcal{R}}} (\mathbf{T} - \mathbf{\Sigma}) \cdot \delta \mathbf{h} dV = 0 \quad . \end{aligned} \quad (13.38)$$

In favor of a brief notation, we use the integral over $\partial\mathcal{R}_{\mathcal{R}}^{\bar{\mathbf{t}}}$ to indicate the summation of single integrals over the surfaces $\partial\mathcal{R}_{\mathcal{R}}^{\bar{\mathbf{t}}_i}$, which generally are not identical. The meaning of integration over $\partial\mathcal{R}_{\mathcal{R}}^{\bar{\mathbf{t}}^{(d)}}$ is analogous.

13.2.2 Time integration

Let the material state (i.e., the value of all variables appearing in the constitutive equations) be known at time t . Suppose now Δu_i are increments of displacement in $\mathcal{R}_{\mathcal{R}}$, inducing the displacement gradient ΔH_{ij} , and Δh_{ij} are increments of microscopic displacement gradient in $\mathcal{R}_{\mathcal{R}}$. They lead to the material

state at time $t + \Delta t$, where Δt is a sufficiently small time increment for the time integration scheme applied to be valid. Denote by $X(t)$ the value of an arbitrary variable at time t , and by $X(t + \Delta t)$ its value at time $t + \Delta t$. After time integration, once the initial state is known, the value of $X(t + \Delta t)$ will be a functional of the increments $\Delta \mathbf{H}$, $\Delta \mathbf{h}$ for plasticity, and a functional of $\Delta \mathbf{H}$, $\Delta \mathbf{h}$ and Δt for viscoplasticity. Alternatively, for fixed Δt , one may thought of $X(t + \Delta t)$ to be a function of $\Delta \mathbf{H}$, $\Delta \mathbf{h}$ and $\frac{\partial \Delta \mathbf{h}}{\partial \mathbf{X}}$, from which we shall make use in the following. The time integration procedure used in our work is the classical elastic predictor and plastic corrector method (see, e.g., references cited in [36, 161, 162]), and is no further commented here. Following common notation (see e.g. [166, 167] or [68]), in the ensuing analysis the known values of quantities at time t are indicated by an upper index 0, while the values of quantities at time $t + \Delta t$ will be indicated by an upper index 1. Then,

$$\Delta \mathbf{u} := \mathbf{x}^{(1)} - \mathbf{x}^{(0)} = \mathbf{u}^{(1)} - \mathbf{u}^{(0)} \quad , \quad \mathbf{H}^{(1)} = \frac{\partial \mathbf{u}^{(1)}}{\partial \mathbf{X}} \quad , \quad \mathbf{H}^{(0)} = \frac{\partial \mathbf{u}^{(0)}}{\partial \mathbf{X}} \quad , \quad (13.39)$$

and hence $\Delta \mathbf{H} := \frac{\partial \Delta \mathbf{u}}{\partial \mathbf{X}} = \mathbf{H}^{(1)} - \mathbf{H}^{(0)}$. Analogous relations apply to the microcontinuum, so that

$$\mathbf{H}^{(1)} = \Delta \mathbf{H} + \mathbf{H}^{(0)} \quad , \quad \mathbf{h}^{(1)} = \Delta \mathbf{h} + \mathbf{h}^{(0)} \quad . \quad (13.40)$$

13.2.3 Linearization

The finite element method requires to solve iteratively equations (13.35), (13.36), accompanied by the constitutive relations. Let the material state at time t be known, and suppose that equilibrium is satisfied in \mathcal{R}_t . For given time increment Δt , consider the boundary conditions at $t + \Delta t$ to be known. We seek for the equilibrium state in $\mathcal{R}_{t+\Delta t}$, where $\mathcal{F}_L = 0$ and $\mathcal{F}_A = 0$ have to hold. According to the remarks in Sect. 13.2.2, all state variables at $t + \Delta t$ are functions of $\Delta \mathbf{H}$ and $\Delta \mathbf{h}$ or, because of (13.40), functions of $\mathbf{H}^{(1)}$ and $\mathbf{h}^{(1)}$, with $\mathbf{H}^{(0)}$, $\mathbf{h}^{(0)}$ being fixed. Since $\mathbf{H}^{(1)}$ is a functional of $\mathbf{u}^{(1)}$, \mathcal{F}_L and \mathcal{F}_A , at time $t + \Delta t$, represent functionals of $\mathbf{u}^{(1)}$, $\mathbf{h}^{(1)}$ and Δt . That means, at time $t + \Delta t$, Eqs. (13.37), (13.38) have the form

$$\mathcal{F}_L(\mathbf{u}^{(1)}, \mathbf{h}^{(1)}, \Delta t, \delta \mathbf{u}, \delta \mathbf{h}) = 0 \quad , \quad (13.41)$$

$$\mathcal{F}_A(\mathbf{u}^{(1)}, \mathbf{h}^{(1)}, \Delta t, \delta \mathbf{u}, \delta \mathbf{h}) = 0 \quad . \quad (13.42)$$

Now, hold Δt fixed and seek iteratively solutions for $\mathbf{u}^{(1)}$ and $\mathbf{h}^{(1)}$. During the iterative approach the solid passes from the nonequilibrium state in $\mathcal{R}_{t+\Delta t}^{(i)}$ to the state in $\mathcal{R}_{t+\Delta t}^{(i+1)}$, $i = 0, 1, 2, \dots$ (see Fig. 13.1). The latter furnishes the solution if equilibrium is approximately satisfied. We shall write $\mathbf{u}^{(0)} = \mathbf{x}^{(0)} - \mathbf{X}$ for the displacement at time t of the material point, which in \mathcal{R}_R has the position vector \mathbf{X} . For the same material point we write $\mathbf{x}_{(i)}^{(1)} \equiv \mathbf{x}_{(i)}$, $\mathbf{u}_{(i)} = \mathbf{x}_{(i)} - \mathbf{X}$ and $\Delta_{(i)} \mathbf{u} = \mathbf{x}_{(i+1)} - \mathbf{x}_{(i)}$, so that

$$\mathbf{u}_{(i+1)} = \mathbf{u}_{(i)} + \Delta_{(i)} \mathbf{u} \quad , \quad (13.43)$$

$$\mathbf{H}_{(i+1)} := \mathbf{H}(\mathbf{u}_{(i)} + \Delta_{(i)} \mathbf{u}) = \frac{\partial(\mathbf{u}_{(i)} + \Delta_{(i)} \mathbf{u})}{\partial \mathbf{X}} = \mathbf{H}_{(i)} + \Delta_{(i)} \mathbf{H} \quad . \quad (13.44)$$

In analogy, we set

$$\mathbf{h}_{(i+1)} = \mathbf{h}_{(i)} + \Delta_{(i)} \mathbf{h} \quad . \quad (13.45)$$

It is worth noting, that $\Delta_{(i)} \mathbf{u}$ differs from $\Delta \mathbf{u} = \mathbf{x}^{(1)} - \mathbf{x}^{(0)}$, introduced in the last section. Indeed, $\Delta_{(i)} \mathbf{u}$ joins $\mathcal{R}_{t+\Delta t}^{(i)}$ to $\mathcal{R}_{t+\Delta t}^{(i+1)}$, while $\Delta \mathbf{u}$ joins \mathcal{R}_t to $\mathcal{R}_{t+\Delta t}$. Even if one introduces the numerical counterpart

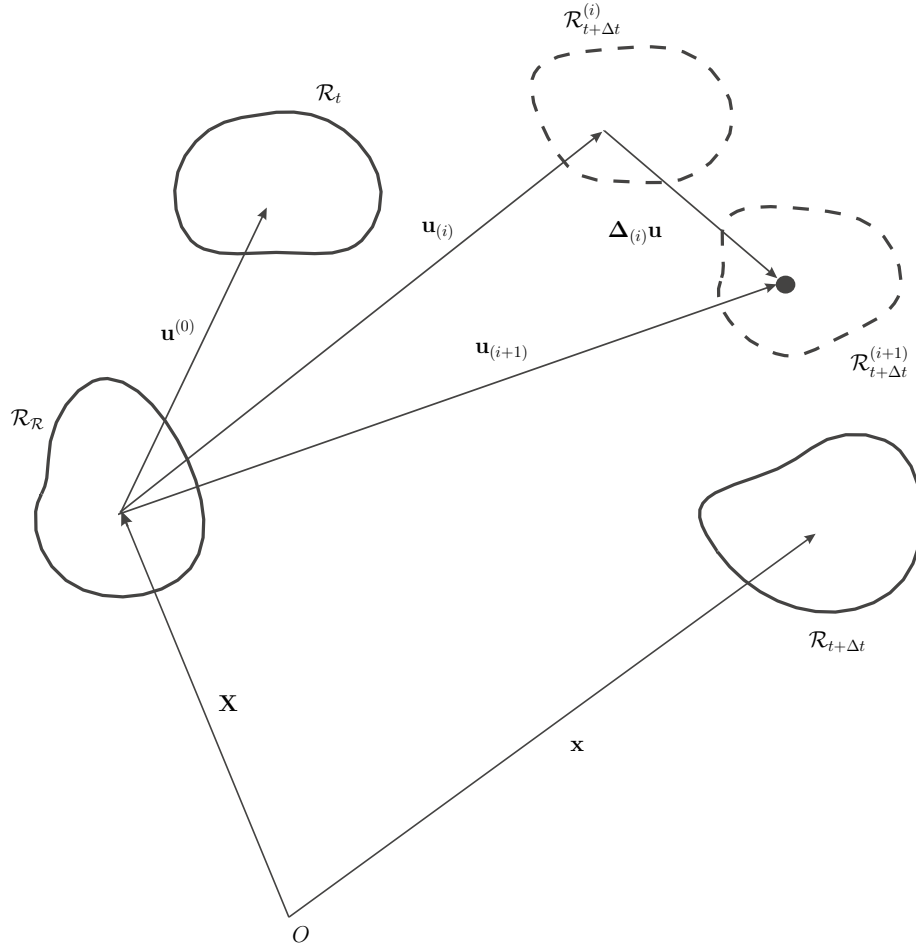
 Figure 13.1: Displacements at times t and $t + \Delta t$.

of $\Delta \mathbf{u}$ to be $\mathbf{x}_{(i)}^{(1)} - \mathbf{x}^{(0)}$, this is different than $\Delta_{(i)} \mathbf{u}$. Similarly, $\Delta_{(i)} \mathbf{h}$ differs from $\Delta \mathbf{h}$, introduced also in the last section.

The iterative approach employed commonly consists in replacing $\mathbf{u}^{(1)}$ and $\mathbf{h}^{(1)}$ in (13.41) and (13.42) by the iterative counterparts (13.43), (13.44) and (13.45). Since Δt is held fixed, we have (cf. (13.37), (13.38))

$$\mathcal{F}_L(\mathbf{u}_{(i)} + \Delta_{(i)} \mathbf{u}, \mathbf{h}_{(i)} + \Delta_{(i)} \mathbf{h}, \delta \mathbf{u}, \delta \mathbf{h}) = \int_{\partial \mathcal{R}_R^t} \bar{\mathbf{t}} \cdot \delta \mathbf{u} dA - \int_{\mathcal{R}_R} \mathbf{T}^{(i+1)} \cdot \frac{\partial \delta \mathbf{u}}{\partial \mathbf{X}} dV = 0 \quad , \quad (13.46)$$

$$\begin{aligned} \mathcal{F}_A(\mathbf{u}_{(i)} + \Delta_{(i)} \mathbf{u}, \mathbf{h}_{(i)} + \Delta_{(i)} \mathbf{h}, \delta \mathbf{u}, \delta \mathbf{h}) &= \\ &= \int_{\partial \mathcal{R}_R^{t(d)}} \bar{\mathbf{t}}^{(d)} \cdot \delta \mathbf{h} dA - \int_{\mathcal{R}_R} \mathcal{T}^{(i+1)} \cdot \frac{\partial \delta \mathbf{h}}{\partial \mathbf{X}} dV + \int_{\mathcal{R}_R} (\mathbf{T}^{(i+1)} - \Sigma^{(i+1)}) \cdot \delta \mathbf{h} dV = 0 \quad . \end{aligned} \quad (13.47)$$

It is convenient to define

$$\mathcal{U} := (\mathbf{u}_{(i)} + \lambda \Delta_{(i)} \mathbf{u}, \mathbf{h}_{(i)} + \mu \Delta_{(i)} \mathbf{h}, \delta \mathbf{u}, \delta \mathbf{h}) \quad , \quad (13.48)$$

with λ, μ being scalars. Then, (13.46), (13.47) become

$$\mathcal{F}_L(\mathcal{U})|_{\lambda=\mu=1} = 0 \quad , \quad (13.49)$$

$$\mathcal{F}_A(\mathcal{U})|_{\lambda=\mu=1} = 0 \quad . \quad (13.50)$$

As stated in Sect. 13.2.2, the state variables $T_{ij}^{(i+1)}$, $\Sigma_{ij}^{(i+1)}$, $\mathcal{T}_{ijk}^{(i+1)}$ may be imagined to be functions of

$$\mathcal{V} := \left(\mathbf{H}^{(i)} + \lambda \Delta_{(i)} \mathbf{H}, \mathbf{h}^{(i)} + \mu \Delta_{(i)} \mathbf{h}, \frac{\partial \mathbf{h}^{(i)}}{\partial \mathbf{X}} + \mu \frac{\partial \Delta_{(i)} \mathbf{h}}{\partial \mathbf{X}} \right) \quad (13.51)$$

at $\lambda = \mu = 1$. Assuming the external loads $\bar{\mathbf{t}}$ and $\bar{\mathbf{t}}^{(d)}$ to be conservative, the integrals in (13.46), (13.47), involving these terms, are, as in classical theories, independent of deformation of the macro- and the microcontinuum. Consequently, derivatives of these integrals with respect to λ and μ are vanishing.

Next, we linearize $\mathcal{F}_L(\mathcal{U})$ and $\mathcal{F}_A(\mathcal{U})$ at $\lambda = \mu = 0$,

$$\begin{aligned} \mathcal{F}_L(\mathcal{U}) &= [\mathcal{F}_L(\mathcal{U})]_{\lambda=\mu=0} + \left[\frac{\partial}{\partial \lambda} \mathcal{F}_L(\mathcal{U}) \right]_{\lambda=\mu=0} \lambda + \left[\frac{\partial}{\partial \mu} \mathcal{F}_L(\mathcal{U}) \right]_{\lambda=\mu=0} \mu \\ &= [\mathcal{F}_L(\mathcal{U})]_{\lambda=\mu=0} - \int_{\mathcal{R}_{\mathcal{R}}} \left\{ \left[\frac{d}{d\lambda} \mathbf{T}(\mathcal{V}) \right]_{\lambda=\mu=0} \cdot \frac{\partial \delta \mathbf{u}}{\partial \mathbf{X}} \lambda - \left[\frac{d}{d\mu} \mathbf{T}(\mathcal{V}) \right]_{\lambda=\mu=0} \cdot \frac{\partial \delta \mathbf{u}}{\partial \mathbf{X}} \mu \right\} dV \quad , \end{aligned} \quad (13.52)$$

$$\begin{aligned} \mathcal{F}_A(\mathcal{U}) &= [\mathcal{F}_A(\mathcal{U})]_{\lambda=\mu=0} \\ &\quad - \int_{\mathcal{R}_{\mathcal{R}}} \left\{ \left[\frac{d}{d\lambda} \mathbf{T}(\mathcal{V}) \right]_{\lambda=\mu=0} \cdot \frac{\partial \delta \mathbf{h}}{\partial \mathbf{X}} - \left[\frac{d}{d\lambda} (\mathbf{T}(\mathcal{V}) - \Sigma(\mathcal{V})) \right]_{\lambda=\mu=0} \cdot \delta \mathbf{h} \right\} \lambda dV \\ &\quad - \int_{\mathcal{R}_{\mathcal{R}}} \left\{ \left[\frac{d}{d\mu} \mathbf{T}(\mathcal{V}) \right]_{\lambda=\mu=0} \cdot \frac{\partial \delta \mathbf{h}}{\partial \mathbf{X}} - \left[\frac{d}{d\mu} (\mathbf{T}(\mathcal{V}) - \Sigma(\mathcal{V})) \right]_{\lambda=\mu=0} \cdot \delta \mathbf{h} \right\} \mu dV \quad . \end{aligned} \quad (13.53)$$

On substituting into (13.49), (13.50), we obtain the linearized equations we seek,

$$\begin{aligned} \int_{\mathcal{R}_{\mathcal{R}}} \left\{ \left[\frac{d}{d\lambda} \mathbf{T}(\mathcal{V}) \right]_{\lambda=\mu=0} \cdot \frac{\partial \delta \mathbf{u}}{\partial \mathbf{X}} + \left[\frac{d}{d\mu} \mathbf{T}(\mathcal{V}) \right]_{\lambda=\mu=0} \cdot \frac{\partial \delta \mathbf{u}}{\partial \mathbf{X}} \right\} dV = \\ = [\mathcal{F}_L(\mathcal{U})]_{\lambda=\mu=0} = \mathcal{F}_L(\mathbf{u}^{(i)}, \mathbf{h}^{(i)}, \delta \mathbf{u}, \delta \mathbf{h}) \quad , \end{aligned} \quad (13.54)$$

$$\begin{aligned} \int_{\mathcal{R}_{\mathcal{R}}} \left\{ \left(\left[\frac{d}{d\lambda} \mathbf{T}(\mathcal{V}) \right]_{\lambda=\mu=0} + \left[\frac{d}{d\mu} \mathbf{T}(\mathcal{V}) \right]_{\lambda=\mu=0} \right) \cdot \frac{\partial \delta \mathbf{h}}{\partial \mathbf{X}} \right. \\ \left. - \left(\left[\frac{d}{d\lambda} (\mathbf{T}(\mathcal{V}) - \Sigma(\mathcal{V})) \right]_{\lambda=\mu=0} + \left[\frac{d}{d\mu} (\mathbf{T}(\mathcal{V}) - \Sigma(\mathcal{V})) \right]_{\lambda=\mu=0} \right) \cdot \delta \mathbf{h} \right\} dV \\ = [\mathcal{F}_A(\mathcal{U})]_{\lambda=\mu=0} = \mathcal{F}_A(\mathbf{u}^{(i)}, \mathbf{h}^{(i)}, \delta \mathbf{u}, \delta \mathbf{h}) \quad . \end{aligned} \quad (13.55)$$

With the aid of the notation

$$\mathcal{K}_{(i)} = \frac{\partial \mathbf{h}^{(i)}}{\partial \mathbf{X}} \quad , \quad \{\cdot\}_{(i)} = \{\cdot\}_{\mathbf{H}^{(i)}, \mathbf{h}^{(i)}, \mathcal{K}_{(i)}} \quad , \quad (13.56)$$

the unknown derivatives in (13.54), (13.55) are

$$\left[\frac{d}{d\lambda} \mathbf{T}(\mathcal{V}) \right]_{\lambda=\mu=0} = \left\{ \frac{\partial \mathbf{T}}{\partial \mathbf{H}} \right\}_{(i)} [\Delta_{(i)} \mathbf{H}] \quad , \quad (13.57)$$

$$\left[\frac{d}{d\mu} \mathbf{T}(\mathcal{V}) \right]_{\lambda=\mu=0} = \left\{ \frac{\partial \mathbf{T}}{\partial \mathbf{h}} \right\}_{(i)} [\Delta_{(i)} \mathbf{h}] \quad , \quad (13.58)$$

$$\left[\frac{d}{d\lambda} (\mathbf{T}(\mathcal{V}) - \boldsymbol{\Sigma}(\mathcal{V})) \right]_{\lambda=\mu=0} = \left\{ \frac{\partial (\mathbf{T} - \boldsymbol{\Sigma})}{\partial \mathbf{H}} \right\}_{(i)} [\Delta_{(i)} \mathbf{H}] \quad , \quad (13.59)$$

$$\left[\frac{d}{d\mu} (\mathbf{T}(\mathcal{V}) - \boldsymbol{\Sigma}(\mathcal{V})) \right]_{\lambda=\mu=0} = \left\{ \frac{\partial (\mathbf{T} - \boldsymbol{\Sigma})}{\partial \mathbf{h}} \right\}_{(i)} [\Delta_{(i)} \mathbf{h}] \quad , \quad (13.60)$$

$$\left[\frac{d}{d\lambda} \mathcal{T}(\mathcal{V}) \right]_{\lambda=\mu=0} = 0 \quad , \quad (13.61)$$

$$\left[\frac{d}{d\mu} \mathcal{T}(\mathcal{V}) \right]_{\lambda=\mu=0} = \left\{ \frac{\partial \mathcal{T}}{\partial \mathcal{K}} \right\}_{(i)} \left[\frac{\partial \Delta_{(i)} \mathbf{h}}{\partial \mathbf{X}} \right] \quad . \quad (13.62)$$

In the examples below, the derivatives $\{\cdot\}_{(i)}$ in (13.57)–(13.62), have been calculated numerically.

13.2.4 Discretization

Finite element methods (see, e.g., Hughes [90]) require approximation of the domain $\mathcal{R}_{t+\Delta t}^{(i)}$ by finite elements, $\mathcal{R}_{t+\Delta t}^{(i)} \approx \bigcup_{e=1}^{n_e} (\mathcal{R}_{t+\Delta t}^{(i)})_e$, where n_e is the number of elements. The unknown macrodisplacements $\Delta_{(i)} \mathbf{u}$ and the unknown microscopic displacement gradients $\Delta_{(i)} \mathbf{h}$ are approximated through

$$(\Delta_{(i)} \mathbf{u})_j \approx \sum_{A=1}^{n_u} N_A^u d_{jA}^u \quad , \quad (13.63)$$

$$(\Delta_{(i)} \mathbf{h})_{ij} \approx \sum_{B=1}^{n_h} N_B^h d_{ijB}^h \quad , \quad (13.64)$$

where $(\Delta_{(i)} \mathbf{u})_j$ and $(\Delta_{(i)} \mathbf{h})_{ij}$, similar to the variations $\delta \mathbf{u}$ and $\delta \mathbf{h}$, have to satisfy homogeneous boundary conditions. Capital letters, like A , are used for indices denoting global node numbers, and d_{jA}^u and d_{ijB}^h are nodal macroscopic displacements and nodal microscopic displacement gradients, respectively. Number n_u indicates the number of nodes with macroscopic displacement degrees of freedom, while n_h denotes the number of nodes with microscopic displacement degrees of freedom. The shape functions N_A^u and N_B^h are supposed to be polynomials of order two of space coordinates, and n_u is equal to n_h . Isoparametric elements are employed, i.e., the space coordinates are represented by using the shape functions N_A^u :

$$x_j = \sum_{A=1}^{n_u} N_A^u x_{jA} \quad . \quad (13.65)$$

The variations $(\delta \mathbf{u})_j$ and $(\delta \mathbf{h})_{ij}$ are approximated by

$$(\delta \mathbf{u})_j \approx \sum_{A=1}^{n_u} N_A^u c_{jA}^u \quad , \quad (13.66)$$

$$(\delta \mathbf{h})_{ij} \approx \sum_{B=1}^{n_h} N_B^h c_{ijB}^h \quad . \quad (13.67)$$

Concluding, the approximations above may be incorporated in (13.54), (13.55) to gain, following standard steps according to the finite element procedure, a linear system of equations

$$\mathbf{Kd} = \mathbf{F} \quad , \quad (13.68)$$

with \mathbf{K} being the stiffness matrix, \mathbf{d} denoting the vector of unknown nodal macroscopic displacements and microscopic displacement gradients, and \mathbf{F} indicating the vector of the known forces. System (13.68) can then be solved by applying standard algorithms.

The presented constitutive theory, along with the finite element discretization and the time integration reported above, have been implemented, for the plane strain state, in the finite element code ABAQUS [1, 2]. The plane strain state is defined by

$$\mathbf{u} = \mathbf{u}(X_1, X_2) \quad , \quad u_3 \equiv 0 \quad , \quad \mathbf{h} = \mathbf{h}(X_1, X_2) \quad , \quad h_{3j} \equiv 0 \quad . \quad (13.69)$$

8-node solid elements of the Serendipity class have been employed. The shape functions for the microscopic deformation \mathbf{h} are linear, whereas the shape functions of the macroscopic displacement field are quadratic. Hence, all nodes exhibit degrees of freedom u_1 and u_2 , but not all nodes have degrees of freedom h_{3j} . This choice of shape functions seems to be reasonable, because the macroscopic displacement gradient \mathbf{H} and the microscopic displacement gradient \mathbf{h} are linearly related through the strain tensor $\boldsymbol{\epsilon}$ (cf. Eq. (13.8)), and therefore both quantities are of the same order.

Examples illustrating the capabilities of the theory to capture size effects are given in the next section and are taken from the doctoral thesis of [88], where also more details about the implementation are given. Further examples and interesting results on this topic may be found in [39, 93, 128, 97] as well as [87].

13.3 Examples

In the ensuing analysis, the chosen values of the material parameters do not reflect some responses of realistic material behavior, i.e., they are only of academic interest and serve to discuss basic features of the model. We set

$$A_1^e \equiv \lambda = 1,21 \cdot 10^5 N/mm^2 \quad , \quad A_2^e = \mu + \alpha \quad , \quad A_3^e = \mu - \alpha \quad , \quad (13.70)$$

$$\mu = 8,08 \cdot 10^4 N/mm^2 \quad , \quad (13.71)$$

$$B_1^e \equiv \lambda \quad , \quad B_2^e \equiv \mu + b_2 \quad , \quad b_2 = 10 \cdot \mu \quad , \quad (13.72)$$

$$D_1^e \equiv \lambda \quad , \quad D_2^e \equiv \mu \quad , \quad (13.73)$$

$$C_i^e = 0 \quad \text{for } i \neq 7 \quad , \quad C_7^e = c_7 \geq 0 \quad . \quad (13.74)$$

Although for the case (13.74), important aspects of the constitutive model may be retain inactive, we shall confine ourself on this special case in order to limit the discussion. For what follows, of particular interest is the internal length

$$l_c := \sqrt{\frac{c_7}{\mu}} \quad , \quad (13.75)$$

suggested by the elasticity laws. Firstly, we shall discuss micromorphic elasticity without damage (pure micromorphic elasticity).

13.3.1 Pure micromorphic elasticity

13.3.1.1 Rectangular specimens with circular hole under tension loading

Consider the plane strain problem in Fig. 13.2 where the quadratic section (length b) with a circular hole (radius r) located in the center of the section, is stretched in y direction. With respect to the Cartesian coordinate system x, y , the boundaries $x = \pm \frac{b}{2}$ are assumed to be traction-free. At the boundary $y = -\frac{b}{2}$ the displacement u_y and the traction t_x are assumed to vanish, while at the boundary $y = \frac{b}{2}$, given displacement u_y and traction $t_x = 0$ are imposed. The whole circular hole is assumed to be traction free, while the whole boundary is subjected to vanishing double traction $\mathbf{t}^{(d)}$.

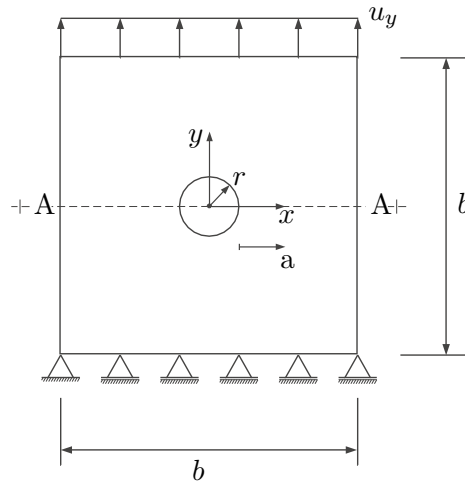

Figure 13.2: Plane strain problem. The quadratic section with a circular hole is stretched in y direction.

For small circular hole, a nearly uniform stress component σ_0 in y direction, at $y = \frac{b}{2}$, will be required to realize the given boundary conditions. In classical elasticity, attention is focussed on the so-called stress concentration factor

$$\frac{T_{yy}^*}{\sigma_0}, \quad T_{yy}^* := T_{yy}(x = r, y = 0), \quad (13.76)$$

which turns out to be equal to 3 (see, e.g., Gould [66, p. 124]), whenever the section is of infinite extension b . In the present context, we refer to as classical, the case where $\alpha \approx 0$, $c_7 \approx 0$, which are approximated numerically for given values of b, r . Particularly, we set $b = 2,5\text{mm}$ and $r = 0,25\text{mm}$, which imply the value $\frac{T_{yy}^*}{\sigma_0} = 3,14$. Typical properties of micromorphic elasticity may be elucidated by regarding the distribution of $\frac{T_{yy}}{\sigma_0}$ along the line $y = 0$ and $x \geq r$, or equivalently $a := x - r \geq 0$. For $\frac{c_7}{\mu} = 0,1\text{mm}^2$ this distribution, parameterized by $\frac{\alpha}{\mu}$, is shown in Fig. 13.3. It can be recognized that increasing values of $\frac{\alpha}{\mu}$ cause decreasing values of $\frac{T_{yy}}{\sigma_0}$ in the neighborhood of $a = 0$, and consequently decreasing values of stress concentration factors $\frac{T_{yy}^*}{\sigma_0}$ for the micromorphic material. Note that all distributions intersect at $a = 0,13\text{mm}$.

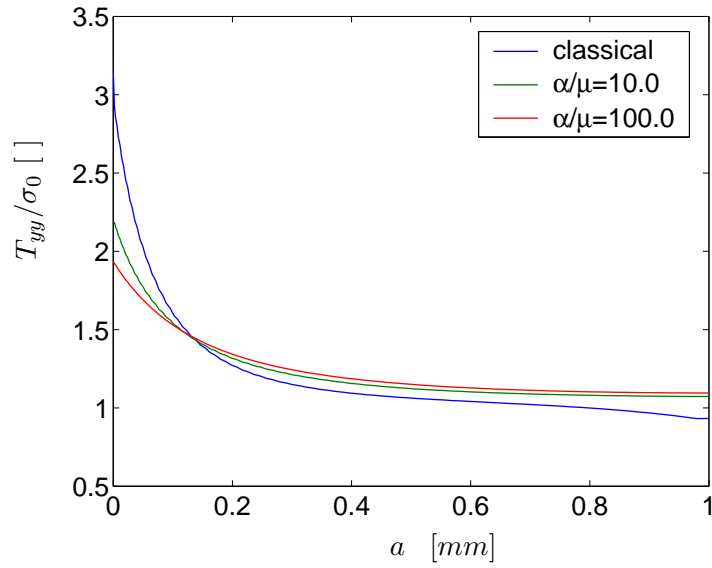

Figure 13.3: Distribution of $\frac{T_{yy}}{\sigma_0}$, $T_{yy} = T_{yy}(y = 0, a \geq 0)$, for $\frac{c_7}{\mu} = 0, 1mm^2$ and varying values $\frac{\alpha}{\mu}$.

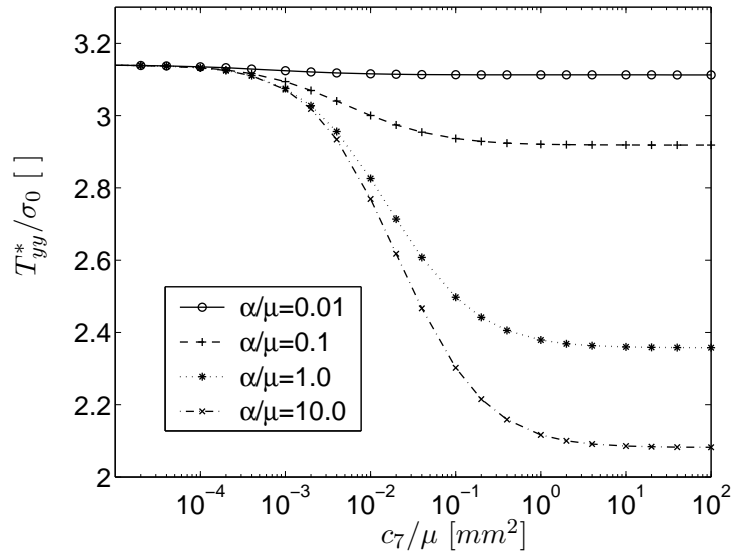

Figure 13.4: Effect of α , c_7 on the stress concentration factor $\frac{T_{yy}^*}{\sigma_0}$.

The effect of α , c_7 on the stress concentration factor is illustrated in Fig. 13.4. For very large values $\frac{\alpha}{\mu}$ and values $\frac{c_7}{\mu} \geq 10^{-3} mm^2$, the stress concentration factor $\frac{T_{yy}^*}{\sigma_0}$ becomes decreasing, whereas for small $\frac{\alpha}{\mu}$ the value of $\frac{T_{yy}^*}{\sigma_0}$ is nearly equal to the classical one. It seems that, at fixed $\frac{\alpha}{\mu}$, $\frac{T_{yy}^*}{\sigma_0}$ converges for $\frac{c_7}{\mu}$ against ∞ or 0, respectively to limits, the limit for $\frac{c_7}{\mu} \rightarrow 0$ being the classical one.

To obtain an insight into the size effects due to different, but otherwise similar boundary value problems, we ask for the stress concentration factor $\frac{T_{yy}^*}{\sigma_0}$ for the cases where $\alpha \equiv \mu$ and geometry and boundary conditions of the specimens vary from each other according to a factor $n = 1, 4, 20, 200$. Corresponding results are displayed in Fig. 13.5, from which we deduce that all distributions are similar. In fact, if the $\frac{T_{yy}^*}{\sigma_0}$ values corresponding to the specimen according to factor n are plotted as a function of $\frac{c_7}{\mu \cdot n^2}$, then all plots will coincide (see Fig. 13.6). In other words, for linear micromorphic elasticity, size effects may be visualized by varying the parameter c_7 , the other parameters being held fixed.

Further size effects may be elucidated by introducing a typical geometry length, as e.g. $l_m := 4r = 0, 4b$. Again we concentrate ourselves on specimen geometries and related boundary conditions, differing according to a factor n , with n being now $n = 0, 0001, 0, 01, \dots, 400, 10000$. On choosing $\frac{c_7}{\mu} = 0, 1 mm^2$, the internal length l_c becomes $l_c = 0, 31623 mm$. It can be seen in Figure 13.7, that the stress concentration factor $\frac{T_{yy}^*}{\sigma_0}$ is a function of the ratio $\frac{l_m}{l_c}$ (cf. also Mindlin [121]).

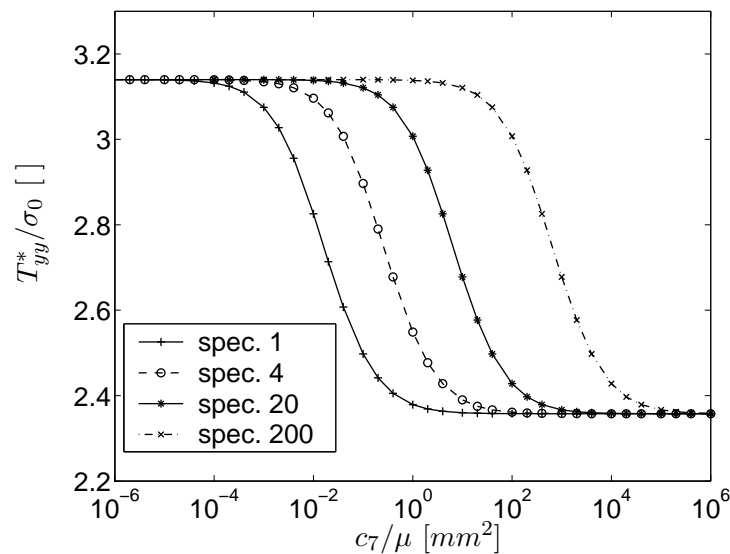

Figure 13.5: Distributions of $\frac{T_{yy}^*}{\sigma_0}$ against $\frac{c_7}{\mu}$, for $\alpha = \mu$ and different specimens. Geometry and boundary conditions of the specimens differ by a factor $n = 1, 4, 20, 200$, the corresponding specimens being referred to as specimen 1, \dots , specimen 200, respectively.

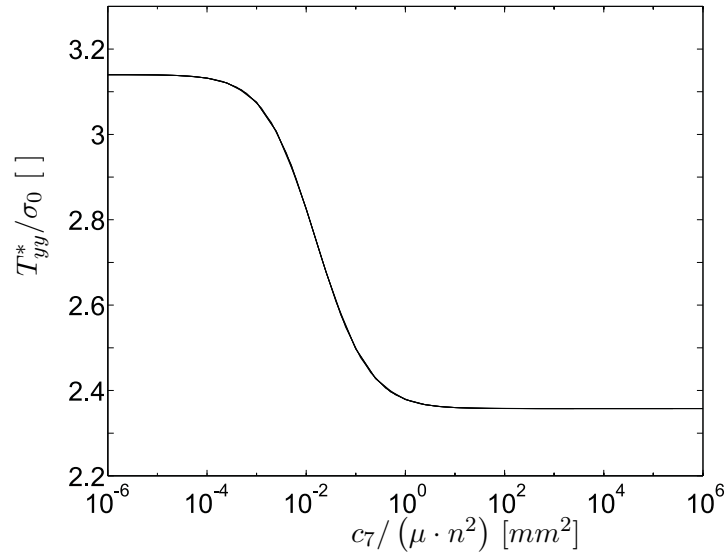

Figure 13.6: Distributions of $\frac{T_{yy}^*}{\sigma_0}$ against $\frac{c_7}{\mu \cdot n^2}$. The results for all specimens ($n = 1, 4, 20, 200$) are identical.

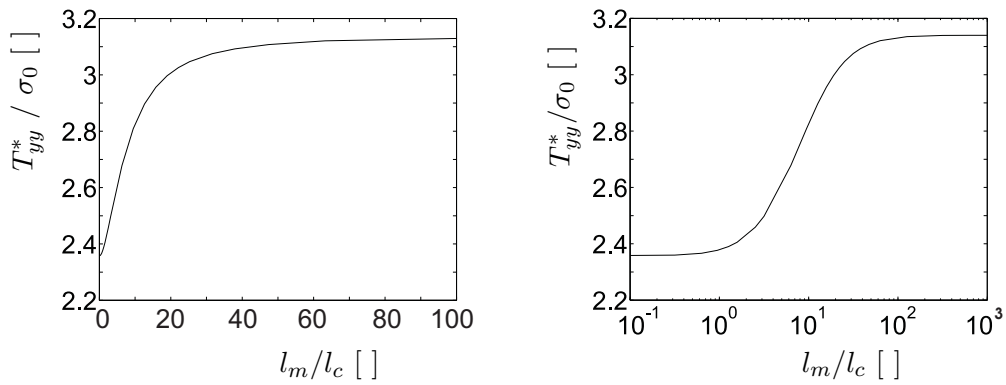

Figure 13.7: Stress concentration factor $\frac{T_{yy}^*}{\sigma_0}$ as a function of the ratio $\frac{l_m}{l_c}$ at $\alpha = \mu$ and $\frac{c_7}{\mu} = 0, 1mm^2$; left: linear plot, right: semilogarithmic plot.

13.3.1.2 Displacement controlled loading of cantilever rectangular beam

Further features of micromorphic elasticity may be illustrated with the aid of the cantilever rectangular beam shown in Fig. 13.8. We use Cartesian coordinates x, y and assume plane strain state to apply, with following boundary conditions,

$$x = 0 \quad : \quad u_y = \bar{u}_y \quad , \quad t_x = 0 \quad , \quad \mathbf{t}^{(d)} = \mathbf{0} \quad , \quad (13.77)$$

$$x = l \quad : \quad \mathbf{u} = \mathbf{0} \quad , \quad \mathbf{h} = \mathbf{0} \quad , \quad (13.78)$$

$$y = 0 \quad : \quad \mathbf{t} = \mathbf{0} \quad , \quad \mathbf{t}^{(d)} = \mathbf{0} \quad , \quad (13.79)$$

$$y = l \quad : \quad \mathbf{t} = \mathbf{0} \quad , \quad \mathbf{t}^{(d)} = \mathbf{0} \quad , \quad (13.80)$$

with the given displacement \bar{u}_y being uniformly distributed along the boundary $x = 0$. Again we focus attention on the effect of the material parameters α and c_7 . Thereby, it is convenient to consider points, which indicate large amounts of stress gradients. Clearly, the edge point $x = l, y = b$ could be selected for this goal. However, such points will exhibit stress distributions with some singularities. Therefore, we shall confine the discussion on points A, B located at a distance of about $0,02 \cdot l$ and $0,17 \cdot l$, from the boundary $x = l$, respectively. Note that the length l and the height b of the beam are chosen to be $l = 3,4375mm$ and $b = 1,25mm$, while the displacement component prescribed on the boundary $x = 0$ amounts $\bar{u}_y = 0,01mm$. Also, A, B are Gauss points with distances from the upper boundary $y = b$, of about $0,033 \cdot b$, respectively. However, we shall refer to such points as being located at the upper boundary $y = b = 1,25mm$. Accordingly, Fig. 13.9 displays the stress component T_{xx} at the boundary $y = b$, as a function of x . It may be seen, that in the neighborhood of $x = l$, the stress component T_{xx} takes vary large values, which designates the singularity in the distribution of T_{xx} .

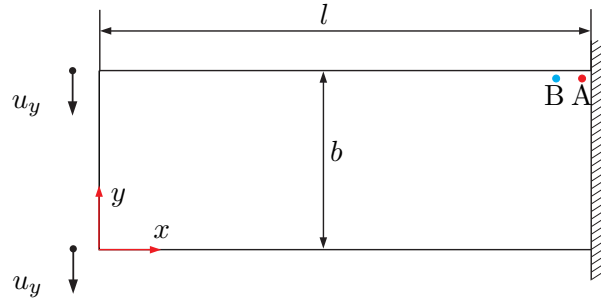

Figure 13.8: Displacement controlled loading of a cantilever rectangular beam, $l = 3,4375mm$, $b = 1,25mm$, $\bar{u}_y = 0,01mm$.

Once more, we denote by "classical", solutions obtained numerically for very small values $\frac{\alpha}{\mu}$ and $\frac{c_7}{\mu}$. Fig. 13.10 makes clear, that in the neighborhood of the singularity (point A), stress component T_{xx} may become larger than $T_{xx}^{(class)}$, dependent on the material parameters α, c_7 . However, with increasing distance from the singularity point, as e.g. at point B , T_{xx} remains smaller than $T_{xx}^{(class)}$, independent of material parameters α, c_7 (see Fig. 13.11).

Significant differences between the shear stress components T_{xy} and T_{yx} may be present, as can be seen in Fig. 13.12, for point A . Both components approach for very large values of $\frac{c_7}{\mu}$, different limits, the one for T_{xy} being vanishing. Of particular interest is also the response of the couple stress $M_c := \mathcal{T}_{xyx} - \mathcal{T}_{yxx}$,

which is shown in Fig. 13.12 too. It can be recognized that M_c is vanishing for small values $\frac{c_7}{\mu}$, while M_c approaches a constant value for very large values $\frac{c_7}{\mu}$.

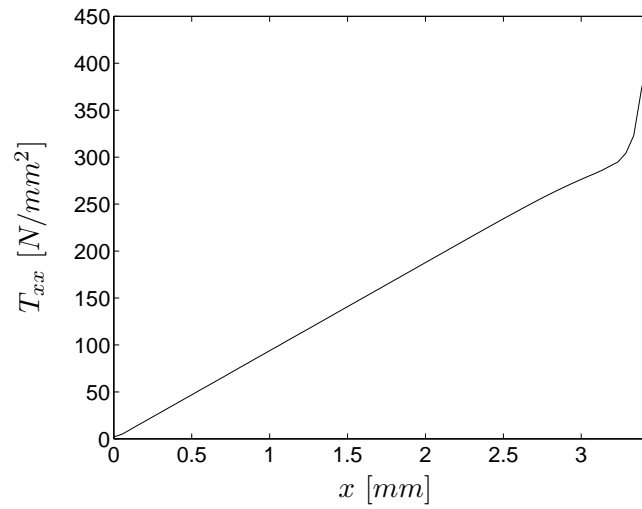

Figure 13.9: Distribution of T_{xx} as a function of x , at the upper boundary $y = b = 1, 25mm$, suggesting a singularity at $x = l$ ($\alpha = 10^{-8} \cdot \mu$, $\frac{c_7}{\mu} = 10^{-8} mm^2$).

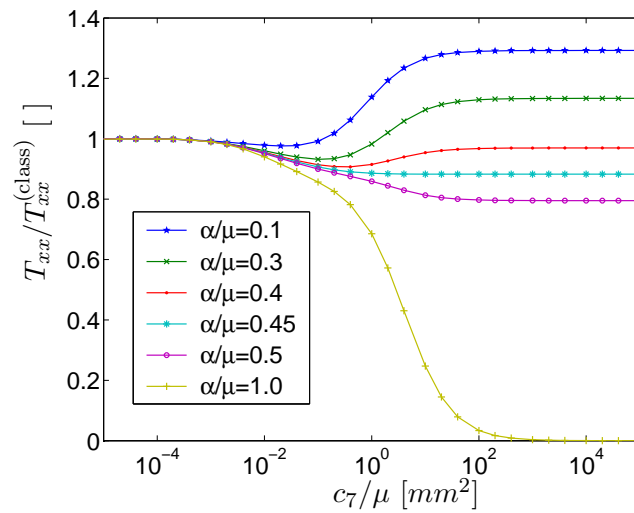

Figure 13.10: Effect of material parameters α , c_7 on the response of stress component T_{xx} for point A (in the vicinity of the singular point $x = l$, $y = b$).

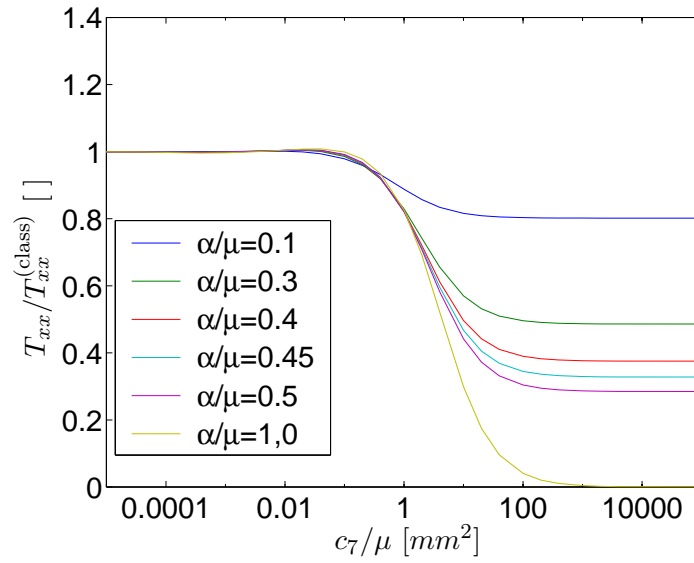

Figure 13.11: Effect of material parameters α , c_7 on the response of stress component T_{xx} for point B (indicating a larger distance than point A from the singular point $x = l$, $y = b$). The values of T_{xx} are always smaller than $T_{xx}^{(class)}$.

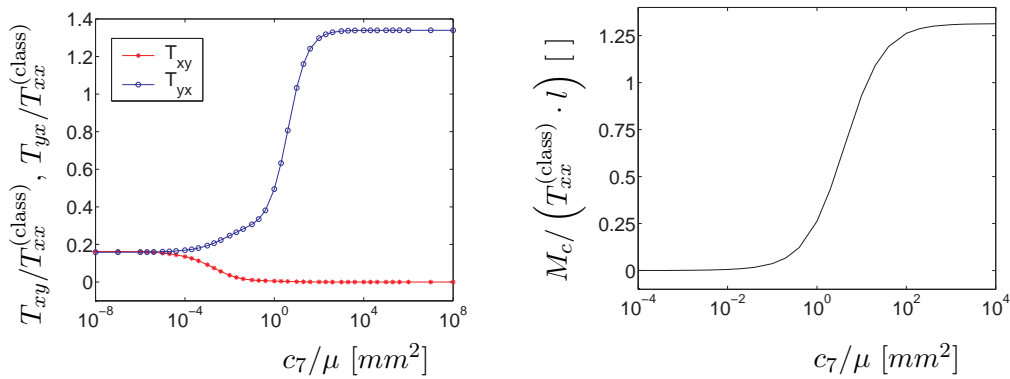

Figure 13.12: Responses of T_{xy} and T_{yx} (left), as well as M_c (right), at point A ($\alpha = 1, 0 \cdot \mu$).

Finally, Fig. 13.13 illustrates, for fixed $\alpha = \mu$, the effect of material parameter c_7 on the deformed geometry of the beam. It may be recognized that for small values of c_7 the bending mode is dominated, while for very large values of c_7 the deformation resamples simple shear mode.

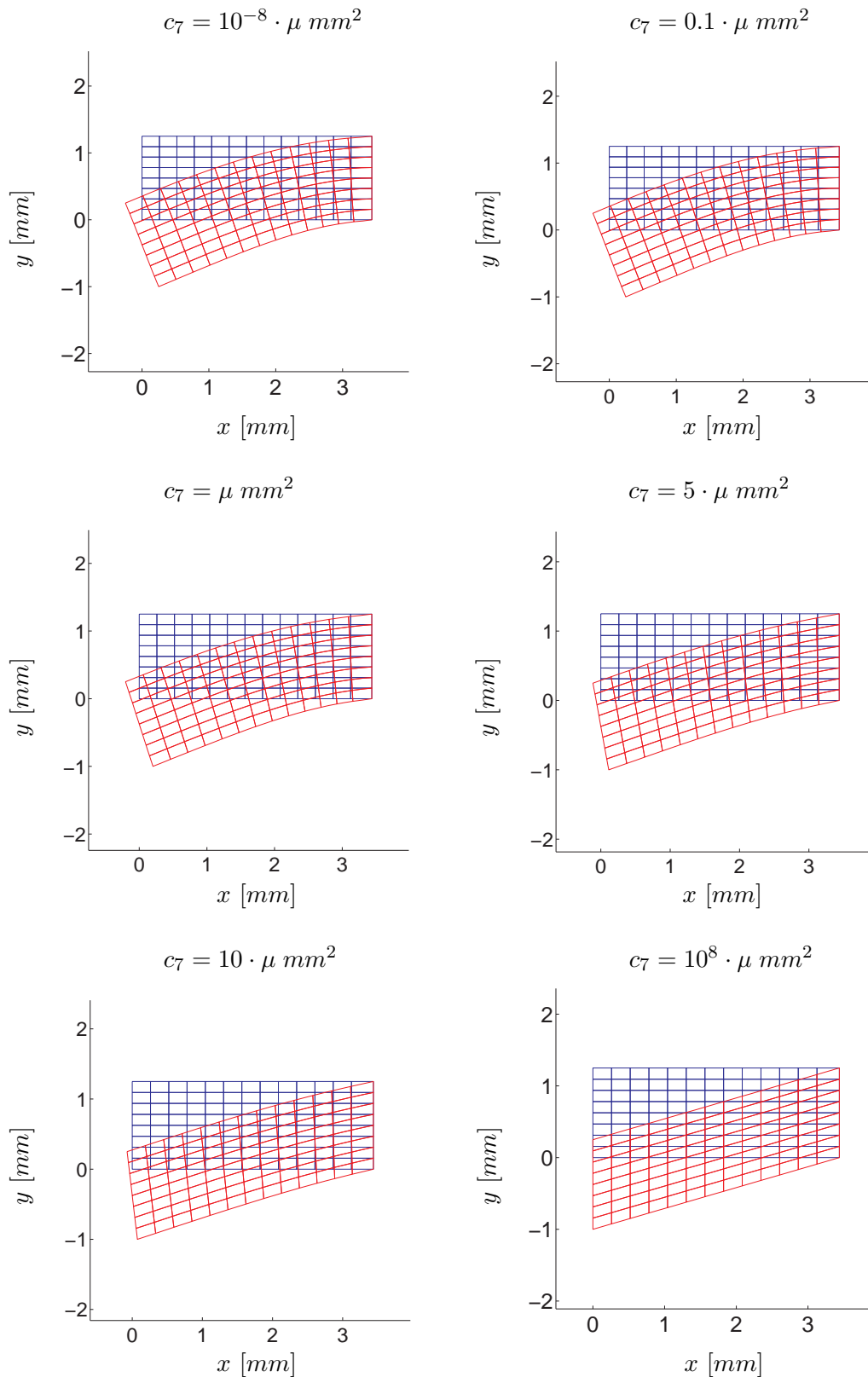

Figure 13.13: Initial and deformed meshes of the rectangular beam for fixed $\alpha = \mu$ and varying material parameter c_7 . Displacements u_y are presented enlarged, by factor 100. The classical case is approached for $c_7 \rightarrow 0$.

13.3.2 Micromorphic plasticity coupled with damage

In the following, we set

$$A_1^y \equiv 0 \quad , \quad A_2^y = 1,5 \quad , \quad A_3^y = 0 \quad , \quad (13.81)$$

$$B_1^y \equiv 0 \quad , \quad B_2^y = 0 \quad , \quad (13.82)$$

$$C_i^y \equiv 0 \quad \text{for } i \neq 7 \quad , \quad C_7^y = r_7 \neq 0 \quad , \quad (13.83)$$

$$k_0 = 350N/mm^2 \quad (13.84)$$

in the yield function, and

$$\beta = 17 \quad , \quad \gamma = 4100N/mm^2 \quad (13.85)$$

in the rule for isotropic hardening. Moreover, we fix the values of α and c_7 in the elasticity laws by

$$\alpha = 0,1 \cdot \mu \quad , \quad \frac{c_7}{\mu} = 0,1mm^2 \quad . \quad (13.86)$$

13.3.2.1 Uniaxial loading

First, we present calculations for homogeneous uniaxial tension loading of a rectangular specimen (plane strain), according to Fig. 13.14. At the bottom of the specimen it is given $u_y = 0$, $t_x = 0$, $\mathbf{t}^{(d)} = \mathbf{0}$, while at the top it is $u_y = \bar{u}_y$, $t_x = 0$, $\mathbf{t}^{(d)} = \mathbf{0}$. The remaining boundaries are subject to the conditions $\mathbf{t} = \mathbf{0}$ and $\mathbf{t}^{(d)} = \mathbf{0}$. The aim is to demonstrate the capabilities of the damage model. To this end, it suffices to concentrate on isotropic hardening only. Further, as the deformations are homogeneous, no material parameters of terms related to micromorphic curvature tensors are involved. Fig. 13.15 shows the effect of the damage parameter α_1 (cf. Eq. (13.34)) on the responses of the uniaxial stress σ and the damage variable D . Further discussion about the damage law for the classical case is provided in [110].

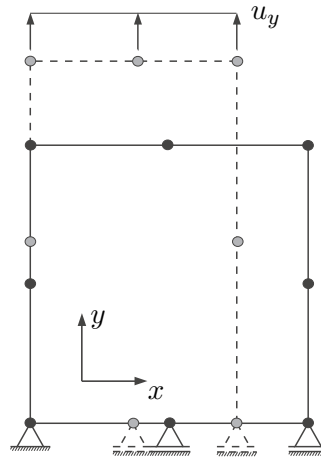

Figure 13.14: Displacement controlled uniaxial loading (1 element, plain strain).

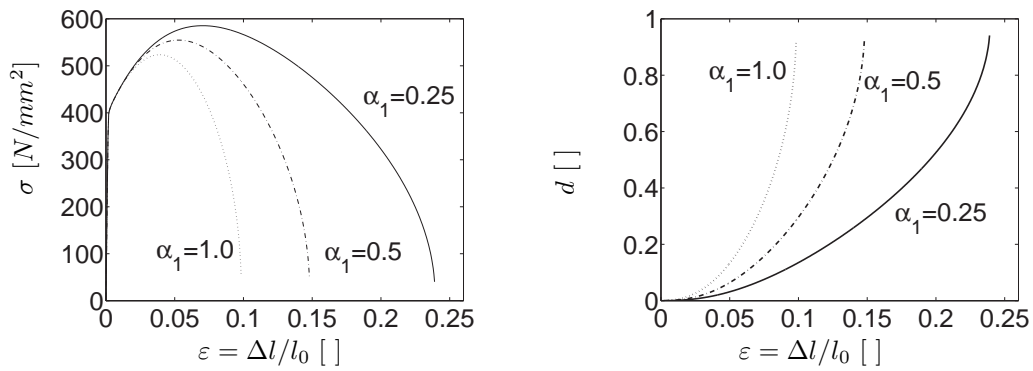

Figure 13.15: Effect of material parameter α_1 on the responses of the uniaxial stress σ (left) and the damage variable D (right).

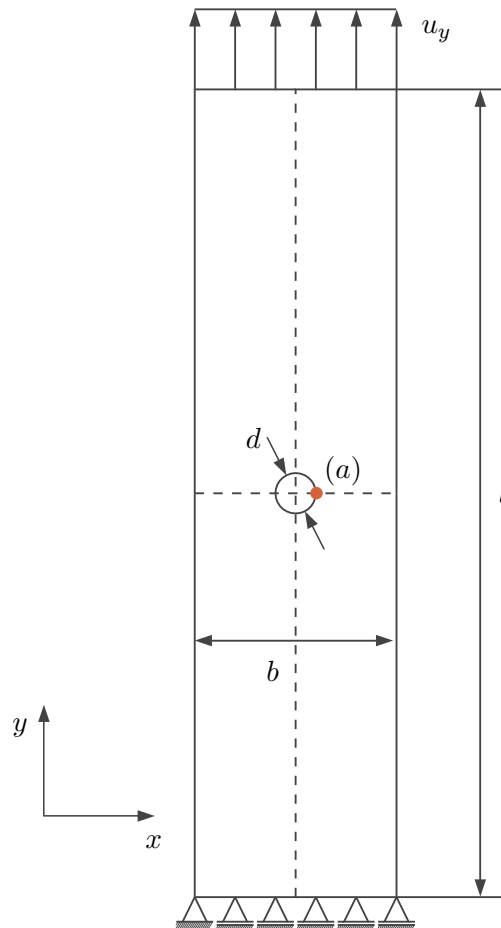

Figure 13.16: Displacement controlled tension loading of rectangular sections with circular hole. All stress responses in the following figures are referred to point (a) on the hole ($x = \frac{b+d}{2}$, $y = \frac{l}{2}$).

13.3.2.2 Rectangular specimens with circular hole under tension loading

We consider again the boundary value problem of Sect. 13.3.1, but now with respect to the specimen geometry displayed in Fig. 13.16 (length l differs from width b). In order to elucidate the capabilities of the micromorphic theory in predicting size effects, four specimen geometries are considered, referred to as specimens 1, 4, 20 and 200 (see Tab. 13.1).

First, only isotropic hardening is addressed, with material parameters as given in Sect. 13.3.2, and $r_7 = 10\text{mm}^{-2}$. The discussion is referred to the stress component T_{yy} at point (a) (see Fig. 13.16). It can be recognized from Fig. 13.17 that softening for large specimens begins earlier than for small ones.

size factor n (number of specimen)	length l [mm]	width b [mm]	diameter d [mm]
spec. 1	10	2,5	1
spec. 4	40	10	4
spec. 20	200	50	20
spec. 200	2000	500	200

Tabelle 13.1: Specimen geometries.

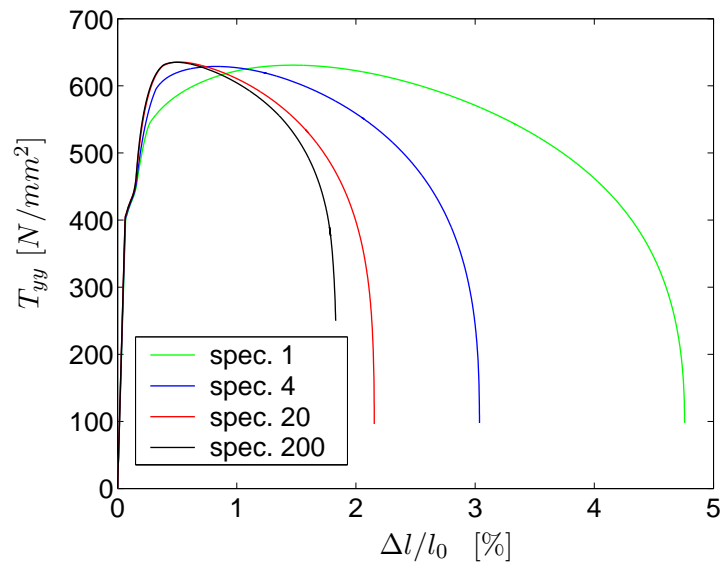

Figure 13.17: Response of the stress component T_{yy} on the hole at point (a) as a function of the global strain $\frac{\Delta l}{l}$ ($\alpha_1 = 0.1$, $r_7 = 10\text{mm}^{-2}$).

Comparison of Fig. 13.17 ($\alpha_1 = 0, 1$) with Fig. 13.18 ($\alpha_1 = 1, 0$) suggests that the form of the responses is strong dependent on the damage parameter α_1 . Moreover, Fig. 13.19 illustrates that maximal values of stresses and maximal global strains depend on the material parameter r_7 , present in the yield function.

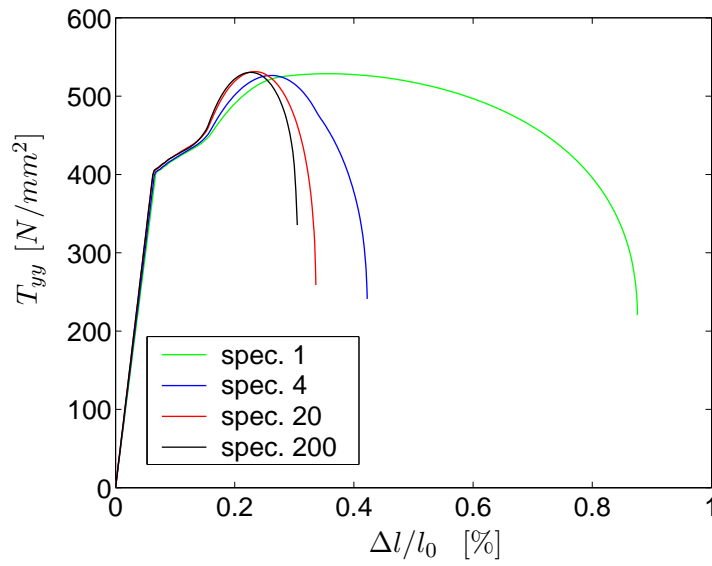

Figure 13.18: Response of the stress component T_{yy} on the hole at point (a) as a function of the global strain $\frac{\Delta l}{l}$ ($\alpha_1 = 1.0$, $r_7 = 10\text{mm}^{-2}$).

Next, we assume the micromorphic model material to exhibit kinematic hardening only, governed by the material parameters

$$r_7 = 10\text{mm}^{-2} \quad , \quad M_2^k = 50\text{mm}^2/\text{N} \quad , \quad A_2^k = A_3^k = 200\text{N}/\text{mm}^2 \quad , \quad (13.87)$$

$$\mathcal{P}_7^k = 500/\text{N} \quad , \quad C_7^k = 200\text{N}/\text{mm} \quad , \quad (13.88)$$

the remaining material parameters related to kinematical hardening being vanishing. Similar to the case of pure isotropic hardening, Fig. 13.20 suggests that, softening for large specimens begins earlier than for small ones. Fig. 13.21 confirms that this holds also for the case of combined isotropic and kinematic hardening.

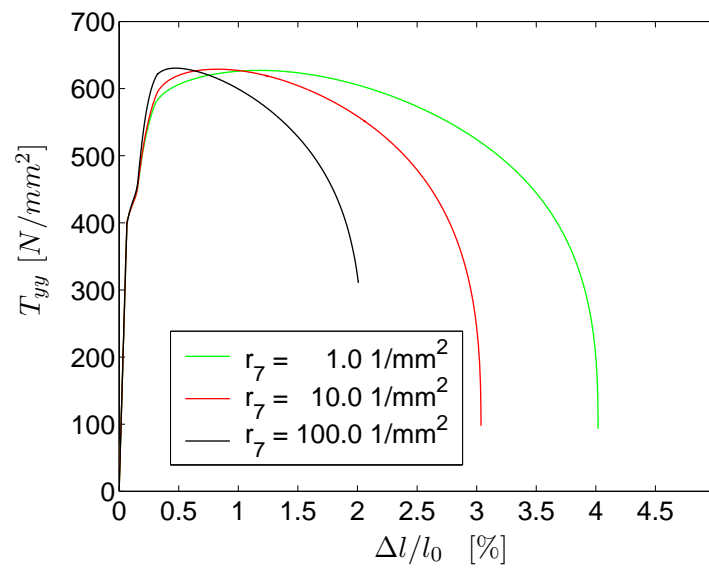

Figure 13.19: Effect of the material parameter r_7 on the response of stress component T_{yy} at (a) (specimen 4, $\alpha_1 = 0, 1$).

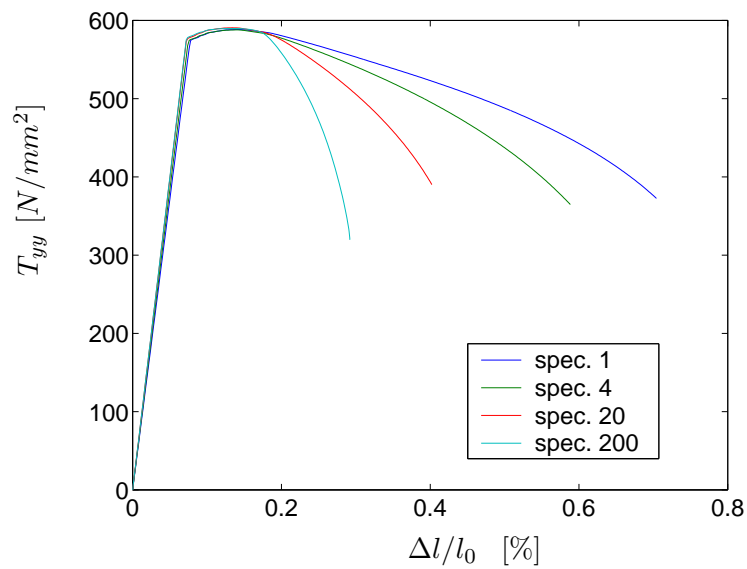

Figure 13.20: Responses of T_{yy} at (a) for pure kinematic hardening ($\alpha_1 = 1$, $k_0 = 500 \text{ N/mm}^2$).

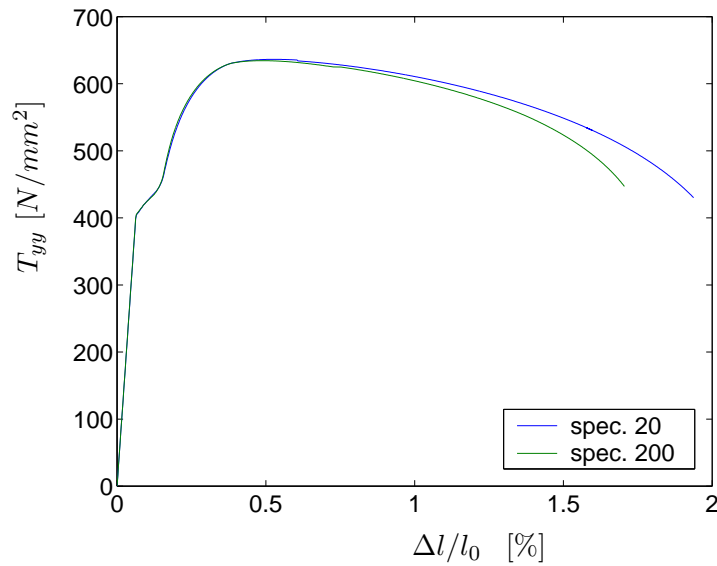

Figure 13.21: Responses of T_{yy} at (a) for combined isotropic and kinematic hardening ($\alpha_1 = 1$, $k_0 = 350\text{N/mm}^2$)

13.4 Concluding remarks

A general framework for micromorphic plasticity has been formulated in Part I, II, incorporating isotropic and kinematic hardening. The hardening laws are of the Armstrong-Frederick type and the yield function is a generalization of the classical v. Mises yield function. Some properties of the resulting theory, concerning prediction of size effects for small deformations, are reported in Part III. However, no comparison with experimental data is available, so that it is not possible to evaluate the appropriateness of the chosen constitutive functions. This concerns over all the yield function and the isotropic hardening, the latter being unifiedly postulated. Further studies, with reference to experimental results will help to clarify such issues, but this is beyond of the scope of the present paper. All the discussions in the three articles make clear, that phenomenological micromorphic theories (at least plasticity theories) are very complicated and involve a large number of material parameters. Therefore, it will be useful to clarify in future works, if it is possible to approximate the essential material responses predicted by micromorphic theories by some simpler gradient models, which deal with classical stresses only, and involve a smaller number of material parameters. Also it is of interest to answer the following question. Is the micromorphic model appropriate enough to describe all known size effects to the necessary degree?

Literaturverzeichnis

- [1] *ABAQUS theory manual, version 6.1.*
- [2] *ABAQUS user's manual, version 6.1.*
- [3] AIFANTIS, E.C.: *On the role of gradients in the localization of deformation and fracture.* International Journal of Engineering Science, 30:1279–1299, 1992.
- [4] AIFANTIS, E.C.: *Strain gradient interpretation of size effects.* International Journal of Fracture, 95:299–314, 1999.
- [5] AIFANTIS, E.C.: *Update on a class of gradient theories.* Mechanics of Materials, 35:259–280, 2003.
- [6] ANTHONY, K.-H.: *Die Theorie der Disklinationen.* Archive for Rational Mechanics and Analysis, 39:43–88, 1970.
- [7] ARMSTRONG, P.J. and C.O. FREDERICK: *A mathematical representation of the multiaxial bauschinger effect.* Technical Report Report No. RD/B/N731, General Electricity Generating Board, Berceley Nuclear Laboratories, 1966.
- [8] BESDO, D.: *Ein Beitrag zur nichtlinearen Theorie des Cosserat-Kontinuums.* Acta Mechanica, 20:105–131, 1974.
- [9] BILBY, B.A., BULLOUGH R. and E. SMITH: *Continuous distributions of dislocations: A new application of the methods of non-riemannian geometry.* Proceedings of the Royal Society A, 231:263–273, 1955.
- [10] BORST, R. DE: *Simulation of strain localization: A reappraisal of the cosserat continuum.* Engineering Computations, 8:317–332, 1991.
- [11] BORST, R. DE: *A generalization of j_2 -flow theory for polar continua.* Computer Methods in Applied Mechanics and Engineering, 103:347–362, 1993.
- [12] BORST, R. DE and H.-B. MÜHLHAUS: *Finite deformation analysis of inelastic materials with micro-structure.* In BESDO, D. and E. STEIN (editors): *Finite Inelastic Deformations – Theory and Applications, IUTAM Symposium Hannover, Germany, 1991*, pages 313–322. Springer, 1992.
- [13] CASEY, J. and P.M. NAGHDI: *A remark on the use of the decomposition $\mathbf{F} = \mathbf{F}_e \mathbf{F}_p$ in plasticity.* Journal of Applied Mechanics, 47:672–675, 1980.
- [14] CASEY, J. and P.M. NAGHDI: *A correct definition of elastic and plastic deformation and its computational significance.* Journal of Applied Mechanics, 48:983–985, 1981.

- [15] CASEY, J. and M. TSENG: *A constitutive restriction related to convexity of yield surfaces in plasticity*. Journal of Applied Mechanics, 35:478–496, 1984.
- [16] CERMELLI, P. and M.E. GURTIN: *On the characterization of geometrically necessary dislocations in finite plasticity*. Journal of the Mechanics and Physics of Solids, 49:1539–1568, 2001.
- [17] CHABOCHE, J.-L.: *Continuum damage mechanics: Part 1 - general concepts*. Journal of Applied Mechanics, 55:59–72, 1988.
- [18] CHABOCHE, J.-L.: *Constitutive equations for cyclic plasticity and cyclic viscoplasticity*. International Journal of Plasticity, 5:247–302, 1989.
- [19] CHABOCHE, J.-L.: *Cyclic viscoplastic constitutive equations. part i: A thermodynamically consistent formulation*. Journal of Applied Mechanics, 60:813–821, 1993.
- [20] CHABOCHE, J.-L.: *Cyclic viscoplastic constitutive equations. part ii: Stored energy-comparison between models and experiments*. Journal of Applied Mechanics, 60:822–828, 1993.
- [21] CHABOCHE, J.-L.: *Thermodynamically founded cdm models for creep and other conditions*. In ALTENBACH H., SKRZYPEK J.J. (editor): *Creep and damage in materials and structures*, volume CISM No. 399, pages 209–278. Springer Verlag New York, 1999.
- [22] CHEN, K.C.: *Noncanonical poisson brackets for elastic and micromorphic solids*. International Journal of Solids and Structures, 44:7715—7730, 2007.
- [23] CHOW, C.L. and T.J. LU: *A normative representation of stress and strain for continuum damage mechanics*. Theoretical and Applied Fracture Mechanics, 12:161–187, 1989.
- [24] CHOW, C.L. and T.J. LU: *An analytical and experimental study of mixed-mode ductile fracture under nonproportional loading*. International Journal of Damage Mechanics, 1:191–236, 1992.
- [25] CHOW, C.L. and J. WANG: *An anisotropic theory of elasticity for continuum damage mechanics for ductile fracture*. International Journal of Fracture, 33:3–16, 1987.
- [26] CLAYTON, J.D., MCDOWELL D.L. and D.J. BAMMANN: *Modeling dislocations and disclinations with finite micropolar elastoplasticity*. International Journal of Plasticity, 22:210–256, 2006.
- [27] CLEJA-TIGOIU, S.: *Couple stresses and non-riemannian plastic connection in finite elastoplasticity*. Zeitschrift für angewandte Mathematik und Physik, 53:996–1013, 2002.
- [28] COLEMAN, B.D. and M.E. GURTIN: *Thermodynamics with internal state variables*. Journal of Chemical Physics, 47:597–613, 1967.
- [29] CORDEBOIS, J.P. and F. SIDOROFF: *Damage induced elastic anisotropy*. In BOEHLER, J.P. (editor): *Mechanical Behavior of Anisotropic Solids*, pages 761–774. Martinus Nijhoff, Boston, 1983.
- [30] COSSERAT, E. and F. COSSERAT: *Théorie des Corps Déformables*. Herman et fils, Paris, 1909.
- [31] CROSS, J.J.: *Mixtures of fluids and isotropic solids*. Archives of Mechanics, 25:1025–1039, 1973.
- [32] DAFALIAS, Y.F.: *Il'vushin's postulate and resulting thermodynamic conditions on elastic-plastic*

- coupling*. International Journal of Solids and Structure, 13:239–251, 1977.
- [33] DIEBELS, S.: *A micropolar theory of porous media: Constitutive modelling*. Transport in Porous Media, 34:193–208, 1999.
- [34] DIEBELS, S. and W. EHLERS: *On fundamental concepts of multiphase micropolar materials*. Technische Mechanik, 16:77–88, 1996.
- [35] DIEGELE, E., HARTMANN ST. and CH. TSAKMAKIS: *Finite deformation plasticity and viscoplasticity laws exhibiting nonlinear hardening rules part ii: Representative examples*. Computational Mechanics, 25:13–27, 2000.
- [36] DIEGELE, E., JANSOHN W. and CH. TSAKMAKIS: *Finite deformation plasticity and viscoplasticity laws exhibiting nonlinear hardening rules part i: Constitutive theory and numerical integration*. Computational Mechanics, 25:1–12, 2000.
- [37] DIEPOLDER, W., MANNL V. and H. LIPPMANN: *The cosserat continuum, a model for grain rotations in metals?* International Journal of Plasticity, 7:313–328, 1991.
- [38] DIETSCHKE, A. and K. WILLAM: *Boundary effects in elasto-plastic cosserat continua*. International Journal of Solids and Structures, 7:877–893, 1997.
- [39] DILLARD, T., FOREST S. and P. IENNY: *Micromorphic continuum modelling of the deformation and fracture behaviour of nickel foams*. European Journal of Mechanics A/Solids, 25:526–549, 2006.
- [40] DLUZIEWSKI, P.: *On geometry and continuum thermodynamics of movement of structural defects*. Mechanics of materials, 22:23–41, 1996.
- [41] EHLERS, W. and W. VOLK: *On shear band localization phenomena induced by elasto-plastic consolidation of fluid-saturated soils*. In OWEN, D.R.J., ONATE E. and E. HINTON (editors): *Computational Plasticity - Fundamentals and Applications*, pages 1657–1664. CIMNE, Barcelona, 1997.
- [42] EHLERS, W. and W. VOLK: *On shear band localization phenomena of liquid-saturated granular elastoplastic porous solid materials accounting for fluid viscosity and micropolar solid rotations*. Mechanics of Cohesive-Frictional Materials, 2:301–320, 1997.
- [43] EHLERS, W. and W. VOLK: *On the theoretical and numerical methods in the theory of porous media based on polar and non-polar elasto-plastic solid materials*. International Journal of Solids and Structures, 35:4597–4617, 1998.
- [44] EPSTEIN, M. and G.A. MAUGIN: *The energy-momentum tensor and material uniformity in finite elasticity*. Acta Mechanica, 83:127–133, 1990.
- [45] ERINGEN, A.C.: *Theory of micropolar elasticity*. In LIEBOWITZ, H. (editor): *An Advanced Treatise*, pages 621–729. Academic Press, New York, 1968.
- [46] ERINGEN, A.C.: *Microcontinuum field theories: I. Foundations and Solids*. Springer Verlag, New York, 1999.
- [47] ERINGEN, A.C. and W.D. CLAUS: *A micromorphic approach to dislocation theory and its*

- relation to several existing theories.* In SIMMONS, J.A., DE WIT R. and R. BULLOUGH (editors): *Fundamental Aspects of Dislocation Theory*, pages 1023–1040. Nat. Bur. Stand. (U.S.) Spec. Publ. 317, II, 1970.
- [48] ERINGEN, A.C. and C.B. KAFADAR: *Polar field theories.* In ERINGEN, A.C. (editor): *Continuum Physics IV*, pages 2–75. Academic Press, New York, 1976.
- [49] ERINGEN, A.C. and E.S. SUHUBI: *Nonlinear theory of simple micro-elastic solids—i.* International Journal of Engineering Sciences, 2:189–203, 1964.
- [50] FLECK, N.A., HUANG Y. NIX W.D. and J.W. HUTCHINSON: *Strain gradient plasticity: Theory and experiment.* Acta Metallurgica et Materialia, 42:475–487, 1994.
- [51] FLECK, N.A. and J.W. HUTCHINSON: *A phenomenological theory for strain gradient effects in plasticity.* Journal of the Mechanics and Physics of Solids, 41:1825–1857, 1993.
- [52] FLECK, N.A. and J.W. HUTCHINSON: *A reformulation of strain gradient plasticity.* Journal of the Mechanics and Physics of Solids, 49:2245–2271, 2001.
- [53] FOREST, S., BARBE F. and G. CAILLETAUD: *Cosserat modelling of size effects in the mechanical behaviour of polycrystals and multi-phase materials.* International Journal of Solids and Structures, 37:7105–7126, 2000.
- [54] FOREST, S.: *Modelling slip, kink and shear banding in classical and generalized single crystal plasticity.* Acta Materialia, 9:3265–3281, 1998.
- [55] FOREST, S. and R. SIEVERT: *Elastoviscoplastic constitutive frameworks for generalized continua.* Acta Mechanica, 160:71—111, 2003.
- [56] FOREST, S. and R. SIEVERT: *Nonlinear microstrain theories.* International Journal of Solids and Structures, 43:7224—7245, 2006.
- [57] FORSTER, CH., HATIRA F.B. and K. SAANOUNI: *On anelastic flow with damage.* International Journal of Damage Mechanics, 3:140–169, 1994.
- [58] FOSDICK, R. and E. VOLKMANN: *Normality and convexity of the yield surface in non-linear plasticity.* Quarterly of Applied Mathematics, 51:117–127, 1993.
- [59] FRANKEL, R.: *The geometry of physics.* Cambridge University Press, Cambridge, second edition edition, 2004.
- [60] GALLERNEAU, F. and J.-J. CHABOCHE: *Fatigue life prediction of single crystals for turbine blade applications.* International Journal of Damage Mechanics, 8:404–427, 1999.
- [61] GALLERNEAU, F., NOUAILHAS D. and J.-J. CHABOCHE: *A fatigue damage model including interaction effects with oxidation and creep damages.* In LUTJERING, G. and H. NOWACK (editors): *Proc. of the Sixth Int. Fatigue Congress, FATIGUE'96*, pages 861–866, 1996.
- [62] GERMAIN, P.: *The method of virtual power in continuum mechanics. part 2 : Microstructure.* SIAM Journal on Applied Mathematics, 25:556–575, 1973.
- [63] GIESSEN, E. VAN DER: *Continuum models of large deformation plasticity. part i: Large defor-*

- mation plasticity and the concept of a natural reference state.* European Journal of Mechanics - A/Solids, 8:15–34, 1989.
- [64] GIESSEN, E. VAN DER: *Continuum models of large deformation plasticity. part ii: A kinematic hardening model and the concept of a plastically induced orientational structure.* European Journal of Mechanics - A/Solids, 8:89–108, 1989.
- [65] GÜNTHER, W.: *Zur Statik und Kinematik des Cosseratschen Kontinuums.* Abhandlungen der Braunschweigischen Wiss. Ges., 10:195–213, 1958.
- [66] GOULD, PH.L.: *Introduction to linear elasticity.* Springer, New York, Berlin, 1983.
- [67] GRAMMENOUDIS, P. and CH. TSAKMAKIS: *Hardening rules for finite deformation micropolar plasticity: Restrictions imposed by the second law of thermodynamics and the postulate of il'ushin.* Continuum Mechanics and Thermodynamics, 13:325–363, 2001.
- [68] GRAMMENOUDIS, P. and CH. TSAKMAKIS: *Classical limits of a micropolar plasticity model.* In GEORGIU, G., PAPANASTASIOU P. and M. PAPADRAKAKIS (editors): *Proceedings of GRACM 05, VOLUME 1, 5th GRACM International Congress on Computational Mechanics Limassol, Cyprus, 29 June – 1 July 2005, Dedicated to the Memory of Professor John H. Argyris*, pages 511–518. Kantzilaris Publications, Nicosia, 2005.
- [69] GRAMMENOUDIS, P. and CH. TSAKMAKIS: *Finite element implementation of large deformation micropolar plasticity exhibiting isotropic and kinematic hardening effects.* International Journal for Numerical Methods in Engineering, 62:1691–1720, 2005.
- [70] GRAMMENOUDIS, P. and CH. TSAKMAKIS: *Predictions of microtorsional experiments by micropolar plasticity.* Proceedings of the Royal Society A, 461:189–205, 2005.
- [71] GRAMMENOUDIS, P. and CH. TSAKMAKIS: *Micropolar plasticity theories and their classical limits. part i: Resulting model.* Acta Mechanica, 189:151–175, 2007.
- [72] GRAMMENOUDIS, P. and CH. TSAKMAKIS: *Incompatible deformations – plastic intermediate configuration.* Z. Angew. Math. Mech., 88:403–432, 2008.
- [73] GRAMMENOUDIS, P. and CH. TSAKMAKIS: *Micromorphic continuum. part i: Strain and stress tensors and their associated rates.* accepted for publication in *International Journal of Non-Linear Mechanics*.
- [74] GRAMMENOUDIS, P. and CH. TSAKMAKIS: *Micromorphic continuum. part ii: Finite deformation plasticity coupled with damage.* accepted for publication in *International Journal of Non-Linear Mechanics*.
- [75] GRAMMENOUDIS, P. and CH. TSAKMAKIS: *Plastic intermediate configuration and related spatial differential operators in micromorphic plasticity.* accepted for publication in *Mathematics and Mechanics of Solids*.
- [76] GRAMMENOUDIS, P., RECKWERTH D. and CH. TSAKMAKIS: *Continuum damage models based on energy equivalence. part i: Isotropic material response.* International Journal of Damage Mechanics, 18:65–91, 2009.
- [77] GRAMMENOUDIS, P., RECKWERTH D. and CH. TSAKMAKIS: *Continuum damage models based*

- on energy equivalence. part ii: Anisotropic material response.* International Journal of Damage Mechanics, 18:31–63, 2009.
- [78] GREEN, A.E. and P.M. NAGHDI: *Some remarks on elastic–plastic deformations at finite strains.* International Journal of Engineering Sciences, 9:1219–1229, 1971.
- [79] GURTIN, M.E.: *On the plasticity of single crystals: free energy, microforces, plastic-strain gradients.* Journal of the Mechanics and Physics of Solids, 48:989–1036, 2000.
- [80] GURTIN, M.E.: *A gradient theory of single-crystal viscoplasticity that accounts for geometrically necessary dislocations.* Journal of the Mechanics and Physics of Solids, 50:5–32, 2002.
- [81] HAUPT, P. and CH. TSAKMAKIS: *On the application of dual variables in continuum mechanics.* Continuum Mechanics and Thermodynamics, 1:165–196, 1989.
- [82] HAUPT, P. and CH. TSAKMAKIS: *Stress tensors associated with deformation tensors via duality.* Archives of Mechanics, 48:347–384, 1996.
- [83] HAYHURST, D.R.: *Creep rupture under multiaxial state of stress.* Journal of the Mechanics and Physics of Solids, 20:381–390, 1972.
- [84] HEHL, F. und E. KRÖNER: *Zum Materialgesetz eines elastischen Mediums mit Momentenspannungen.* Z. Naturforsch., 20a:336–350, 1965.
- [85] HILL, R.: *On constitutive inequalities for simple materials - ii.* Journal of the Mechanics and Physics of Solids, 16:315–322, 1968.
- [86] HILL, R. and J.R. RICE: *Elastic potentials and the structure of inelastic constitutive laws.* SIAM, 25:448–461, 1973.
- [87] HIRSCHBERGER, C.B., KUHL E. and P. STEINMANN: *On deformational and configurational mechanics of micromorphic hyperelasticity - theory and computation.* Computer Methods in Applied Mechanics and Engineering, 196:4027–4044, 2007.
- [88] HOFER, D.: *Simulation von Größeneffekten mit mikromorphen Theorien.* doctoral thesis, TU Darmstadt, 2003.
- [89] HUBER, N. and CH. TSAKMAKIS: *A neural network tool for identifying the material parameters of a finite deformation viscoplasticity model with static recovery.* Computer Methods in Applied Mechanics and Engineering, 191:353–384, 2001.
- [90] HUGHES, T.J.R.: *The Finite Element Method: Linear Static and Dynamic Finite Element Analysis.* Prentice-Hall, Englewood Cliffs, New Jersey, 1987.
- [91] HÄUSLER, O. und CH. TSAKMAKIS: *Torsion eines Kreiszyinders bei großen Deformationen und inkompressiblem Materialverhalten.* Wissenschaftliche Berichte FZKA 5598, Forschungszentrum Karlsruhe, Technik und Umwelt, 1995.
- [92] KACHANOV, L.M.: *Time of the rupture process under creep conditions.* Isv. Akad. Nauk. SSR. Otd Tekh. Nauk., pages 26–31, 1958.
- [93] KIRCHNER, N. and P. STEINMANN: *A unifying treatise on variational principles for gradient*

- and micromorphic continua*. Philosophical Magazine, 85:3875—3895, 2005.
- [94] KONDO, K.: *Non-riemannian geometry of imperfect crystals from a macroscopic viewpoint*. In KONDO, K. (editor): *RAAG Memoirs of the Unifying Study of Basic Problems in Engineering and Physical Science by Means of Geometry D-1*, pages 6–17. Gakuyesty Bunken Fukin-Kay, Tokyo, 1955.
- [95] KRÖNER, E.: *Continuum theory of defects*. In BALIAN, R., KLEMAN M. and J.-P. POIRIER (editors): *Physics of defects*, pages 215–315. North-Holland Publishing Company, Amsterdam - New York - Oxford, 1980.
- [96] LAZAR, M.: *Dislocation theory as a 3-dimensional translation gauge theory*. Ann. Phys. (Leipzig), 6:461–473, 2000.
- [97] LAZAR, M. and G.A. MAUGIN: *On microcontinuum field theories: the eshelby stress tensor and incompatibility conditions*. Philosophical Magazine, 87:3853—3870, 2007.
- [98] LE, K.C. and H. STUMPF: *Finite elastoplasticity with microstructure*. Mitteilungen aus dem Institut für Mechanik, Ruhr-Universität Bochum - Mitteilungen Nr. 92, 1994.
- [99] LE, K.C. and H. STUMPF: *On the determination of crystal reference in nonlinear continuum theory of dislocations*. Proceedings of the Royal Society A, 452:359–371, 1996.
- [100] LEE, E.H.: *Elastic plastic deformation at finite strain*. ASME Trans. Journal of Applied Physics, 36:1–6, 1969.
- [101] LEE, E.H. and D.T. LIU: *Finite strain elastic-plastic theory with application to plane-wave analysis*. Journal of Applied Physics, 38:19–27, 1967.
- [102] LEMAITRE, J.: *How to use damage mechanics*. Nuclear Engineering and Design, 80:233–245, 1984.
- [103] LEMAITRE, J.: *A continuous damage mechanics model for ductile fracture*. Journal of Engineering Materials and Technology, 107:83–89, 1985.
- [104] LEMAITRE, J.: *Formulation and identification of damage kinetic constitutive relations*. In KRAJČINOVIC, D. and J. LEMAITRE (editors): *Continuum Damage Mechanics: Theory and Applications*, pages 37–89. Springer- Verlag Wien, New York, 1987.
- [105] LEMAITRE, J.: *Formulation unifiée des lois d'évolution d'endommagement*. C. R. Acad. Sci. Paris, Série II, 305:1125–1130, 1987.
- [106] LEMAITRE, J.: *A course on damage mechanics (Second Ed.)*. Springer Verlag New York, 1996.
- [107] LEMAITRE, J. and J.-L. CHABOCHE: *Mechanics of Solid Materials*. Cambridge University Press, 1990.
- [108] LIN, H.C. and M.P. NAGHDI: *Necessary and sufficient conditions for the validity of a work inequality in finite plasticity*. Quarterly Journal of Mechanics and Applied Mathematics, 42:13–21, 1989.
- [109] LIPPMANN, H.: *Eine Cosserat-Theorie des plastischen Fließens*. Acta Mechanica, 8:255–284,

1969.

- [110] LÄMMER H., TSAKMAKIS CH.: *Discussion of coupled elastoplasticity and damage constitutive equations for small and finite deformations*. International Journal of Plasticity, pages 495–523, 2000.
- [111] LU, T.J. and C.L. CHOW: *On constitutive equations of inelastic solids with anisotropic damage*. Theoretical and Applied Fracture Mechanics, 14:187–218, 1990.
- [112] LUBLINER, J.: *Normality rules in large-deformation plasticity*. Mechanics of Materials, 5:29–34, 1986.
- [113] LUBLINER, J.: *Plasticity Theory*. Macmillan Publishing Company, New York, 1990.
- [114] LUCCHESI, M. and M. SILHAVY: *Il'iusin's conditions in non-isothermal plasticity*. Archive for Rational Mechanics and Analysis, 113:121–163, 1991.
- [115] MA, Q. and D. CLARKE: *Size dependent hardness of silver single crystals*. Journal of Materials Research, 10:853–863, 1995.
- [116] MALVERN, L.E.: *Introduction to the Mechanics of a continuous medium*. Prentice Hall, INC., 1969.
- [117] MARSDEN, J.E. and T.J.R. HUGHES: *Mathematical foundation of Elasticity*. Dover Publications, INC., 1983.
- [118] MÜHLHAUS, H.-B. and I. VARDOULAKIS: *The thickness of shear bands in granular materials*. Géotechnique, 37:271–283, 1987.
- [119] MINAGAWA, S.: *Elastic fields of dislocations and disclinations in an isotropic micropolar continuum*. Letters in Applied and Engineering Sciences, 5:85–94, 1977.
- [120] MINAGAWA, S.: *A non-riemannian geometrical theory of imperfections in a cosserat continuum*. Archives of Mechanics, 31:783–792, 1979.
- [121] MINDLIN, R.D.: *Influence of couple-stresses on stress concentrations*. Experimental Mechanics, 3:1–7, 1963.
- [122] MINDLIN, R.D.: *Micro-structure in linear elasticity*. Archive for Rational Mechanics and Analysis, 16:51–78, 1964.
- [123] MINDLIN, R.D. and H.F. TIERSTEN: *Effects of couple-stresses in linear elasticity*. Archive for Rational Mechanics and Analysis, 11:415–448, 1962.
- [124] MISNER, C.W., THORNE K.S. and J.A. WHEELER: *Gravitation*. W.H. Freeman and Company, New York, 1973.
- [125] NAGHDI, P.M. and J. CASEY: *On the characterization of strain-hardening in plasticity*. Journal of Applied Mechanics, 48:285–295, 1981.
- [126] NAGHDI, P.M. and J.A. TRAPP: *The significance of formulation plasticity theory with reference to loading surfaces in strain space*. International Journal of Engineering Science, 13:785–797, 1975.

-
- [127] NEALE, K.W. and S.C. SHRIVASTAVA: *Analytical solutions for circular bars subjectes to large strain plastic torsion*. Journal of Applied Physics, 57:298–306, 1990.
- [128] NEFF, P. and S. FOREST: *A geometrically exact micromorphic model for elastic metallic foams accounting for affine microstructure. modelling, existence of minimizers, identification of moduli and computational results*. Journal of Elasticity, 87:239–276, 2007.
- [129] NOLL, W.: *Materially uniform simple bodies with inhomogeneities*. Archive for Rational Mechanics and Analysis, 27:1–32, 1967.
- [130] NOUAILHAS, D.: *Anisotropic constitutive equations for cyclic viscoplasticity: Application to the case of materilas with cubic symmetry*. Rech. Aerosp., 3:11–28, 1990.
- [131] NOUAILHAS, D. and G. CAILLETAUD: *Tension-torsion behavior of single-crystal superalloys: Experiment and finite element analysis*. International Journal of Plasticity, 11:451–470, 1995.
- [132] NOUAILHAS, D. and J.-L. CHABOCHE: *Anisotropic constitutive modeling for single-crystal superalloys using a continuum phenomenological approach*. In DESAI (editor): *Proc. of 3rd Int. Conf. on Constitutive Laws for Engineering Materials*, pages 213–218. ASME Press, New York, 1991.
- [133] NOUAILHAS, D. and A.D. FREED: *A viscoplastic theory for anisotropic materials*. Journal of Engineering Materials and Technology, 114:97–104, 1992.
- [134] OGDEN, R.W.: *Non-Linear Elastic Deformations*. John Wiley & Sons, 1983.
- [135] POOLE, W., ASHBY M. and N. FLECK: *Micro-hardness of annealed and work-hardened copper polycrystals*. Scripta Materialia, 34:559–564, 1996.
- [136] RABOTONOV, Y.N.: *Creep problems in structural members*. North-Holland, 1969.
- [137] RECKWERTH, D. and CH. TSAKMAKIS: *The principle of generalized energy equivalence in continuum damage mechanics*. In HUTTER, K. and H. BAASER (editors): *Deformation and Failure of Metallic Continua*, pages 381–406. Springer, 2003.
- [138] RISTINMAA, M. and M. VECCHI: *Use of couple-stress theory in elasto-plasticity*. Computer Methods in Applied Mechanics and Engineering, 136:205–224, 1996.
- [139] SANSOUR, C.: *A unified concept of elastic–viscoplastic cosserat and micromorphic continua*. Journal de Physique IV, 8:Pr8–341–348, 1998.
- [140] SATOR, C.: *Der klassische Grenzfall eines mikropolaren Plastizitätsmodells für große Deformationen*, 2004.
- [141] SCHOUTEN, J.A.: *Ricci-Calculus*. Springer-Verlag, Berlin - Göttingen - Heidelberg, 1954.
- [142] SCHUTZ, B.: *Heometrical methods of mathematical physics*. Cambridge University press, Cambridge, 1980.
- [143] SIMO, J.C. and J.W. JU: *Strain- and stress-based continuum damage models-i. formulation*. International Journal of Solids and Structures, 23:821–840, 1987.
- [144] SIMO, J.C. and J.W. JU: *Strain- and stress-based continuum damage models-ii. computational*

- aspects formulation.* International Journal of Solids and Structures, 23:841–869, 1987.
- [145] SIMO, J.C. and M. ORTIZ: *A unified approach to finite deformation elastoplastic analysis based on the use of hyperelastic constitutive equations.* Computer Methods in Applied Mechanics and Engineering, 49:221–245, 1985.
- [146] SKRZYPEK, J.J.: *Material damage models for creep failure analysis and designs of structures.* In ALTENBACH, H. and J.J. SKRZYPEK (editors): *Creep and damage in materials and structures*, volume CISM No. 399, pages 97–160. Springer Verlag New York, 1999.
- [147] SMITH, A.C.: *Inequalities between the constants of a linear micro-elastic solid.* International Journal of Engineering Science, 6:65–74, 1968.
- [148] SRINIVASA, A.R.: *On the nature of the response functions in rate-independent plasticity.* International Journal of Non-Linear Mechanics, 32:103–119, 1997.
- [149] STEINMANN, P.: *A micropolar theory of finite deformation and finite rotation multiplicative elastoplasticity.* International Journal of Solids and Structures, 31:1063–1084, 1994.
- [150] STEINMANN, P. and K. WILLAM: *Localization within the framework of micropolar elastoplasticity.* In BRÜLLER, O., MANNL V. and J. NAJAR (editors): *Advances in Continuum Mechanics*, pages 296–313. Springer, Berlin, 1991.
- [151] STELMASHENKO, A., WALLS M. BROWN L. and Y. MILMAN: *Microindentations on w and mo oriented single crystals: An stm study.* Acta Metallurgica et Materialia, 41:2855–2865, 1993.
- [152] STÖLKEN, J.S. and A.G. EVANS: *A microbend test method for measuring the plasticity length scale.* Acta Materialia, 46:5109–5115, 1998.
- [153] TEJCHMAN, J. and W. WU: *Numerical study on patterning of shear bands in cosserat continuum.* Acta Mechanica, 99:61–74, 1993.
- [154] TOUPIN, R.A.: *Elastic materials with couple-stresses.* Archive for Rational Mechanics and Analysis, 11:385–414, 1962.
- [155] TRUESDELL, C. and W. NOLL: *The non-linear field theories of mechanics.* In S., FLÜGGE (editor): *Handbuch der Physik*, volume III/3. Springer-Verlag, Berlin, Heidelberg, New York, 1965.
- [156] TSAKMAKIS, CH.: *On the loading conditions and the decomposition of deformation.* In BOEHLER, J.-P. and A.S. KHAN (editors): *Anisotropy and localization of plastic deformation*, pages 335–356. Elsevier Applied Science, London & New York, 1991.
- [157] TSAKMAKIS, CH.: *Kinematic hardening rules in finite plasticity. part i: A constitutive approach.* Continuum Mechanics and Thermodynamics, 8:215–231, 1996.
- [158] TSAKMAKIS, CH.: *Kinematic hardening rules in finite plasticity. part ii: Some examples.* Continuum Mechanics and Thermodynamics, 8:233–246, 1996.
- [159] TSAKMAKIS, CH.: *Remarks on il'iushin's postulate.* Archives of Mechanics, 49:677–695, 1997.
- [160] TSAKMAKIS, CH.: *Description of plastic anisotropy effects at large deformations. part I: Re-*

strictions imposed by the second law and the postulate of il'iushin. 2001.

- [161] TSAKMAKIS, CH. and A. WILLUWEIT: *Time integration algorithms for finite deformation plasticity*. In HUTTER, K. and H. BAASER (editors): *Deformation and Failure of Metallic Continua*, pages 79–106. Springer, 2003.
- [162] TSAKMAKIS, CH. and A. WILLUWEIT: *A comparative study of kinematic hardening rules at finite deformations*. International Journal of Non-Linear Mechanics, 39:539–554, 2004.
- [163] VOLK, W.: *Untersuchung des Lokalisierungsverhaltens mikropolarer poröser Medien mit Hilfe der Cosserat-Theorie*. Bericht Nr. II-2, Universität Stuttgart, Institut für Mechanik, Lehrstuhl II, 1999.
- [164] VOYIADJIS, G.Z. and T. PARK: *Anisotropic damage effect tensors for the symmetrization of the effective stress tensor*. Journal of Applied Mechanics, 64:106–110, 1997.
- [165] WANG, C.-C. and C. TRUESDELL: *Introduction to Rational Elasticity*. Noordhoff International Publishing, Leyden, 1973.
- [166] WEBER, G. and L. ANAND: *Finite deformation constitutive equations and a time integration procedure for isotropic, hyperelastic-viscoplastic solids*. Computer Methods in Applied Mechanics and Engineering, 79:173–202, 1991.
- [167] WEBER, G., LUSH A.M. ZAVALIANGOS A. and L. ANAND: *An objective time-integration procedure for isotropic rate-independent and rate-dependent elastic-plastic constitutive equations*. International Journal of Plasticity, 6:701–744, 1990.
- [168] WILLMORE, T.J.: *Riemannian Geometry*. Oxford University Press, Oxford, 1993.
- [169] ZHENG, Q.-S. and J. BETTEN: *On damage effective stress and equivalence hypothesis*. International Journal of Damage Mechanics, 5:219–240, 1996.