

SIEMENS

Breakout Prediction for Continuous Casting by Fuzzy Mealy Automata



Reprint from
Proceedings of the 3rd European Congress of Intelligent Techniques and Soft Computing
EUFIT, Aachen, Germany, August 29-31, 1995, pp. 754-759

Author: J. Adamy

Breakout Prediction for Continuous Casting by Fuzzy Mealy Automata

J. Adamy

Siemens AG, AUT 941 Inter-Group Development
Paul-Gossen-Str. 100, D-91052 Erlangen, Germany

Abstract. During the continuous casting of steel, any disturbances to the cooling process in the casting mould can cause weak points in the shell of the steel strand. As the strand leaves the mould it is possible for liquid metal to break out from these weak points and cause serious damage to the plant. Such breakouts can be avoided by detecting any weak points at an early stage while the strand is still in the mould and by slowing the rate of casting. This will allow more cooling time in the mould so that the defective points can heal over. Weak points can be detected from characteristic patterns in the temperatures measured around the casting mould. Fuzzy Mealy automata are used to recognize the temperature patterns cheaply and reliably. The probability of breakout is then calculated from an analysis of the temperature recognition results.

Key Words. Pattern recognition; fuzzy Mealy automata; continuous casting; breakout prediction.

1 Introduction

The manufacture of steel slab and strip by the continuous casting method or by thin-strip casting involves molten steel being poured continuously into a casting mould. As a result of the external cooling of the mould, the strand forms a solid shell on its exterior as it is drawn continuously out of the mould. Only after it has left the mould does it harden completely.

The crucial feature of the method is the formation of the shell of the strand in the casting mould. The shell is produced by the removal of heat from the molten metal through the water-cooled inner walls of the mould. As a result, the metal solidifies at the sides of the mould, where it forms the shell of the strand. At the same time as the strand is being drawn out of the mould at constant speed, a lubricant called the mould powder is applied between the sides of the mould and the strand to prevent it sticking. During the drawing-out process, until it finally leaves the mould, the shell of the strand becomes gradually stronger and so prevents the still-molten metal escaping from the interior of the strand. At the end of the process the strand is cut up into slabs. Fig. 1 illustrates the process.

Defects in the growth of the strand shell can present considerable problems because they cause weak points in it which can break open after the strand has left the mould. Molten steel can escape from these breakouts and cause serious damage to the plant, which inevitably leads to a loss of production and expensive repairs.

By far the most common growth defect is the so-called "sticker", which is caused by high localized friction between the strand and the mould, e.g. due to a shortage of casting powder [1-3]. At the point of increased friction the strand sticks to the side of the mould more strongly than elsewhere, with the result that its speed at that point is also reduced. This causes stresses in the strand shell and it breaks open. Molten steel gains access to the side of the mould and raises the temperature there. A temperature pattern of this process is shown in Fig. 2a. The temperature variations are measured by means of sensors embedded in the inner walls of the casting mould. After the sticker has passed a measuring point there is a marked drop in temperature below the normal level. This is due to the greater thickness of the shell upstream of the sticker and arises from the reduced speed.

Air cushions, called cracks, which form between the strand and the mould are another cause of breakouts [3]. The low thermal conductivity of the air greatly reduces the transmission of heat from the strand to the mould with the result that a very thin shell is formed on the strand. As a crack passes a temperature sensor it appears as a pronounced dip in the measured temperature pattern, as illustrated in Fig. 2b. Stickers and cracks together account for nearly 96% of all breakouts [3].

If growth defects can be detected while they are forming in the casting mould and the speed of the strand is reduced so that the cooling time in the mould is increased, the defects will be able to heal over [4]. Various methods have, therefore, been developed [2,3,5-8] using temperature measurements taken from

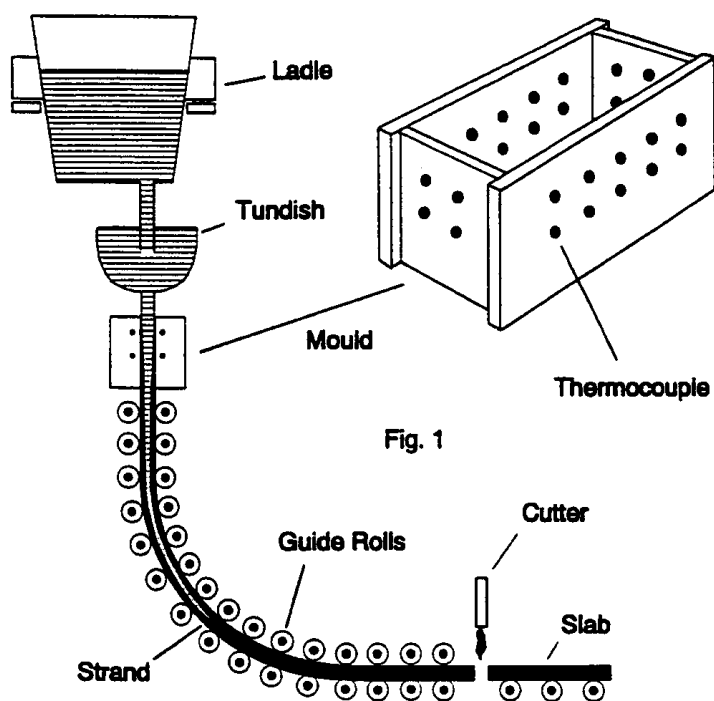
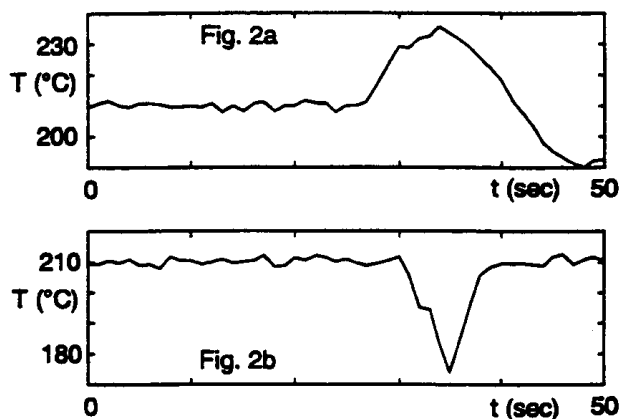

Fig. 1. The continuous casting process with a detail view of the casting mould and the positions of the thermocouples

Fig. 2. Temperature traces with patterns of weak points: (a) Sticker pattern, (b) Crack pattern



the casting mould to detect the presence of defects, especially stickers. The temperature sensors are placed around the mould in one or two rows as shown in Fig. 1. Depending on the particular method, the defects are detected either directly according to the measured values of temperature or their rate of change [6,7] or by a pattern recognition technique, e.g. by means of neural networks [3,8]. In this case, temperature traces are stored and then examined for characteristic patterns such as those shown in Fig. 2. The pattern recognition process is then repeated every time a new measurement is added to the temperature trace.

A method of pattern recognition employing fuzzy Mealy automata that has been developed for the detection of weak points is described below. One of its particular features is that it needs only single, instantaneous measurements and not measured traces of temperature and so is much less costly. Similarly, it is very easy to set up for different patterns.

2 Pattern recognition by fuzzy Mealy automata

As has just been explained, weak points in the shell of the strand cause characteristic patterns in the measured traces of temperature. These occur sequentially as new values are continually added to a trace. The pattern recognition process is, therefore, also used here sequentially with instantaneous measured values, i.e. without knowledge of the trace. This method is faster and more efficient for this application than those methods which have been designed for problems involving patterns already available in their entirety [9-12]. Automata are suitable for sequential pattern recognition [9,13]. Fuzzy automata are especially relevant since they enable the measured values to be transformed into linguistic values which can then be used directly for syntactic pattern recognition [9]. Proposals for fuzzy automata suitable for pattern recognition are made in [14,15].

The pattern recognition automaton presented here provides a continuous value of the probability¹ P of a sticker or crack pattern developing in a temperature trace. The input variables of the automata are solely the temperature $T(i)$ measured in time step i and its rate of change $\Delta T(i) = T(i) - T(i-1)$. This is based on the following idea: Pattern recognition is impossible from instantaneous values of $T(i)$ and $\Delta T(i)$ alone because a single curve point does not form a pattern. This means that it is essential to have other information concerning the trace of measured values. Therefore, the automaton employs the breakout probability $P(i)$ as an internal state variable since $P(i)$ contains the previous development of the temperature trace in extractable form. Fuzzy logic is then used to ascertain the actual probability of breakout $P(i+1)$ from $P(i)$, the representative of previous temperature development, and the instantaneous measured values $T(i)$ and $\Delta T(i)$. The probability value is buffer-stored in the next time step and, as shown in Fig. 3, is fed back to the input of the fuzzy system.

¹The term "probability" is not used here in its statistical meaning, but as a measure of the likelihood of a particular pattern developing.

Recognition of the sticker shown in Fig. 2 then proceeds typically as follows. At the beginning of the sticker, $P(i)$ is zero but the temperature is starting to rise. Therefore, $P(i+1)$ is increased to a small value. T subsequently increases to higher values. If $P(i)$ is already a low value, $P(i+1)$ is increased to a medium value. This value signifies that approximately one third of the sticker pattern was scanned and recognized. The temperature maximum then follows. It is recognized by reference to $T(i)$ and $\Delta T(i)$ and, because the prior history of the trace is identified as sticker by the medium value of $P(i)$, $P(i+1)$ is increased again. In the subsequent part of the pattern $P(i+1)$ is increased continuously on the basis of a previous high value of $P(i)$. It is this conditional sequential increase in P that allows the pattern to be safely identified. A similar situation prevails with cracks. Other patterns do not give rise to high values of P because they do not cause a corresponding sequential process in the automata.

A systematic representation of the automaton described above and its mode of operation is obtained by classifying it as a fuzzy Mealy automaton. Fuzzy Mealy automata derive directly from a generalization of boolean Mealy automata [13]

$$\begin{aligned} z(i+1) &= f(z(i), u(i)) && \text{with input vector } u(i) \\ & && \text{state vector } z(i) \\ y(i) &= g(z(i), u(i)) && \text{output vector } y(i) \end{aligned} \tag{1}$$

when the boolean vector functions f and g are replaced by fuzzy vector functions, i.e. by complete fuzzy systems with fuzzification and defuzzification of input and output variables (see Fig. 4). The vectors u , y and especially also the stored state vector z in Equation (1) are crisp variables.

The proposed pattern recognition automaton is a special case with only one state variable $z(i) = P(i)$, one output variable $y(i) = P(i+1)$ and with

$$g(z(i), u(i)) = f(z(i), u(i)). \tag{2}$$

As with any other fuzzy automata, its mode of operation can be described by means of a fuzzy state graph. Fuzzy state graphs derive from a direct generalization of boolean state graphs. The linguistic values of the state variables form the nodes; for example, the values

Z=Zero, T=Tiny, S=Small, M=Middle, B=Big, H=Huge

for the probability $P(i)$ (see Fig. 5). At the arrows between states, the transient conditions, i.e. the fuzzy rules, that effect a change of state appear in front of the dash. And with Mealy automata, as here, the relevant output value appears after the dash. In Fig. 5, for example, $R2/B$ gives the fuzzy rule set $R2$, which contains the conditions for the change of state from Z to T , and the linguistic value B of the output variables $P(i+1)$.

The state graph illustrates the pattern recognition process: During the course of a pattern the probability only increases step-by-step from Z to H if the pattern causes the rule sets $R2, R5, R9, R13$ and $R17$ to be satisfied one after the other. This is the case with sticker or crack patterns. If the measured pattern deviates slightly from these reference patterns, either the instantaneous state is retained or the next lower state is assumed. If the deviations are greater, one of the rule sets $R3, R8, R12, R16$ or $R20$ is activated, depending on the actual state at the moment. The probability P then becomes Z . Fig. 6 shows the recognition process for a sticker.

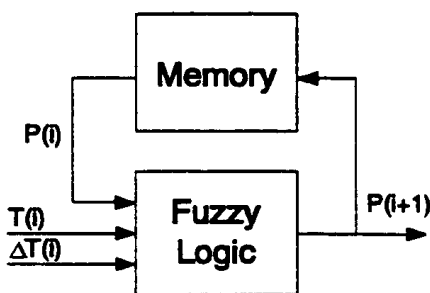

Fig. 3. Pattern recognition by fuzzy automaton

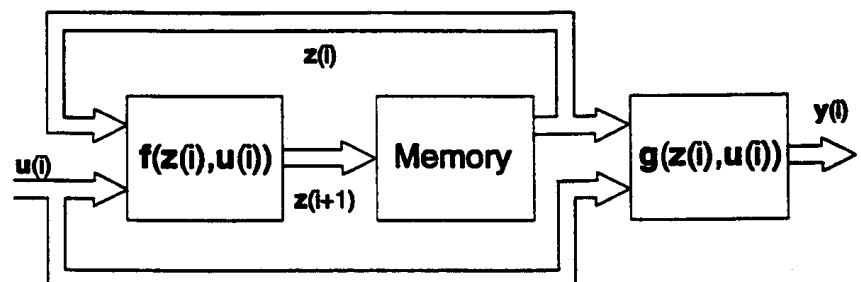
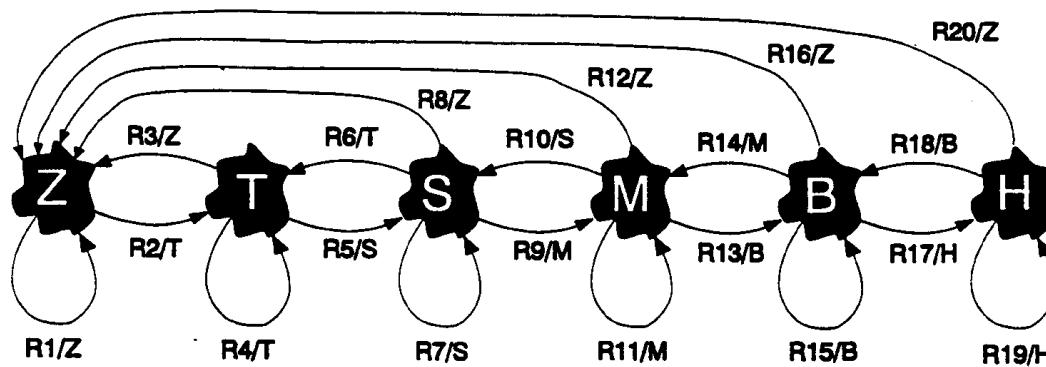

Fig. 4. General structure of a Mealy or fuzzy Mealy automaton



rule set R2			
$T(i)$	$\Delta T(i)$	$P(i)$	$P(i+1)$
PS	Z	Z	T
PS	PS	Z	T
NB	NB	Z	T
NB	NS	Z	T

Linguistic values of T and ΔT

- NB = negative big
- NS = negative small
- Z = zero
- PS = positive small
- PB = positive big
- PH = positive huge

} for ΔT } for T

Fig. 5. State graph of the fuzzy Mealy automaton for pattern recognition and fuzzy rule set R2 as an example of transient conditions. For pattern recognition T is scaled such that the mean value over time is approximately zero.

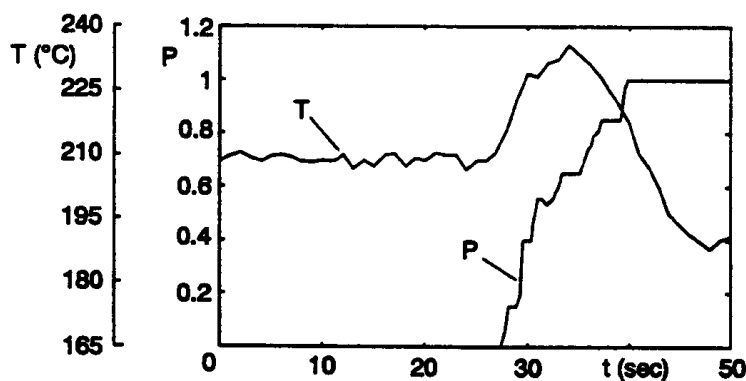

Fig. 6. Example of sticker recognition

In order to complete the design of the automaton, the linguistic values and the rules also need to be supplemented by the membership functions of the variables $T(i)$, $\Delta T(i)$ and $P(i)$ for fuzzification and the membership functions of the variables $P(i+1)$ for defuzzification. Trapezoidal membership function for $T(i)$, $\Delta T(i)$ and $P(i)$ and singletons for $P(i+1)$ are employed for this purpose. The inference is obtained by the max-min method and the defuzzification by the centre-of-gravity method [16]. Basically, however, other types of membership functions, inference methods and defuzzification methods can also be employed [17,18]. It should be noted that the values of $T(i)$ and $\Delta T(i)$ are scaled and filtered, and variations of $T(i)$, which are caused by changes of the casting speed, are compensated before fuzzification is carried out.

The method of pattern recognition described above provides a continuous value of the probability P of a sticker or crack pattern appearing in the measured temperature trace. The automaton is designed so that, firstly, any breakouts threatened by P can be safely predicted and, secondly, the number of recognition errors is low. The accuracy of prediction can be increased even further, as will be described in the next section, by combining the recognition results P from adjacent measured temperature traces.

3 Ascertaining the probability of breakout

Each measured temperature trace is continuously examined by a fuzzy automaton of the type described previously for the presence of patterns caused by stickers or cracks. Due to the elongation of the weak point and the motion of the strand, the pattern occurs in horizontally or vertically adjacent measured temperature traces [2,3,5-8]. Therefore, the detection of a weak point becomes more dependable if it is specified that it can be recognized not in only one temperature trace but in at least two adjacent ones too.

Consequently, the recognition results P_a and P_b from two adjacent temperature traces are combined to

give a localized probability of breakout P_{loc} . On the one hand, this enables the recognition errors of an automaton to be corrected because P_{loc} is only given a high value if both P_a and P_b are high. On the other hand, the detection of weak points is better and faster since higher values of P_a and P_b allow a value of probability for P_{loc} to be estimated that is greater than any individual value of probability P_a or P_b .

These rules are simulated in detailed form by fuzzy logic with the input variables P_a and P_b and the output variables P_{loc} . This type of fuzzy logic is applied to all pairs of P_a and P_b arising from vertically or horizontally adjacent sensors. As Fig. 7 shows, this links the outputs of the fuzzy Mealy automata to the inputs of the fuzzy systems and produces a number of localized breakout probabilities P_{loc} . When there is

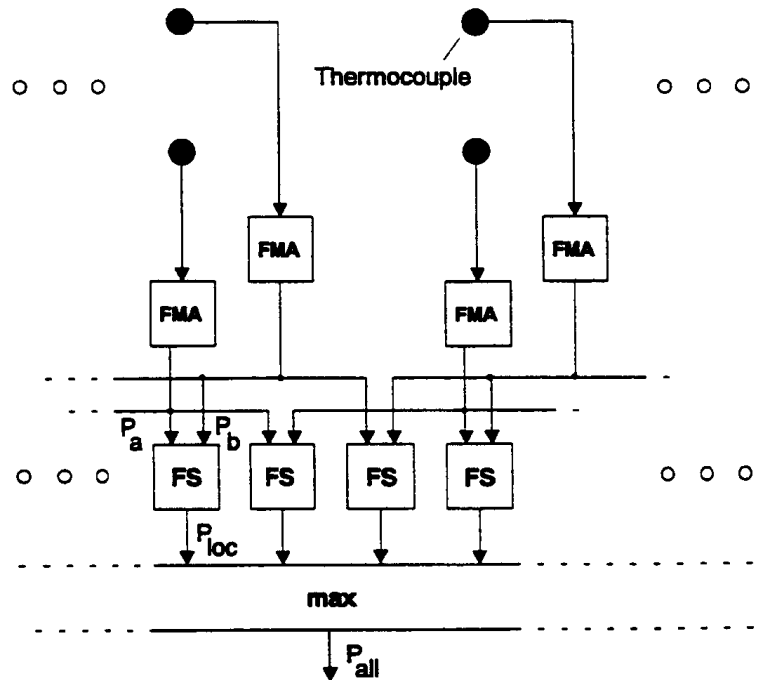

Fig. 7. Structure of the complete recognition system with fuzzy Mealy automata (FMA) and fuzzy systems (FS)

only one horizontal plane of sensors the basic procedure is identical except that there are then no vertical combinations, of course. The maximum value of all localized breakout probabilities P_{loc} provides the overall probability P_{all} of a breakout occurring. An alarm is triggered if P_{all} exceeds a certain predetermined limit.

4 Avoiding breakout by controlling the casting speed

When a breakout alarm is triggered, i.e. a weak point has been detected, the speed of casting v is reduced to a low value v_1 either by an automatic system or manually by the operator. As explained before, this increases the cooling time for the strand in the casting mould so that the shell becomes thicker and the weak point heals over. The period of time ΔT needed to repair the weak point is followed by a slow, ramped return to normal casting speed.

This healing process has been examined in greater detail for stickers, which are the main cause of breakouts [3,4]. The examination has given rise to instructions and rules as to how the values v_1 and ΔT should be chosen and over what periods of time the decrease and re-increase in casting speed should be conducted.

5 Summary

The prediction and avoidance of breakouts is a major task in the continuous casting or thin-strip casting of steel. The method of prediction developed here recognizes characteristic patterns in temperature traces measured at the casting mould which give an early warning of breakout. Since these patterns occur sequentially from continuous measurements, recognition of the patterns is also performed sequentially by means of a special fuzzy Mealy automaton. Thus, no continuous traces of measured data are needed, only instantaneous measured values; which makes the recognition process low-cost and fast. Also, the rule base of

the automaton can be adapted very simply and easily for different patterns. This means that it is generally also suitable for similar problems such as the monitoring of medical data and the detection of sensor errors.

References

- [1] Mills, K.C.; Billany, T.J.H.; Normaton, A.S.; Walker, B. and Grieveson, P.: Causes of sticker breakout during continuous casting. *Ironmaking and Steelmaking*, vol. 18, no. 4, pp. 253-265, 1991
- [2] Lu, M.J.; Lin, K.J.; Kuo, C.H. Kuo and Chien, W.C.: Sticker Breakout Theory and its Prediction in Slab Continuous Casting. *Proc. of the 76th Steelmaking Conference*, Dallas, TX, USA, vol. 76, March 28-31, 1993, pp. 343-353
- [3] Tsuneoka, A.; Ohasi, W.; Ishitobi, S.; Kataoka, T. and Tenma, M.: Measurement and Control System of Solidification in Continuous Casting Mold. *Proc. ISS-AIME Steelmaking Conference*, Detroit, MI, USA, April 1985, pp. 3-10
- [4] Patton, M.A.; Klein, A. and Wolf, M.M.: Advanced Breakout Prevention System Custom-Made to Product Mix. *Proc. of the 74th Steelmaking Conference*, Washington, D.C., USA, vol. 74, April 14-17, 1991, pp. 553-560
- [5] Emling, W.H. and Dawson, S.: Mold Instrumentation for Breakout Detection and Control. *Proc. of the 74th Steelmaking Conference*, Washington, D.C., USA, vol. 74, April 14-17, 1991, pp. 197-217
- [6] Bardet, P.; Leclercq, A.; Mangin, M.; Sarter, B.: Contrôle du processus de coulée continue de brames à la Sollac. *Revue de Metallurgie - CIT*, vol. 80, April 1983, pp. 303-312
- [7] Itoyama, S. et. al.: Process of and Apparatus for Continuous Casting with Detection of Possibility of Break Out. US Patent 4,949,777, Aug. 21,1990
- [8] Tanaka, T.; Endo, H.; Kamada, N.; Naito, S. und Kominami, H.: Trouble Forecasting System by Multi-Neural Network on Continuous Casting Process of Steel Production. In T. Kohonen et. al. (Ed.): *Artificial Neural Networks. Proc. of the 1991 Int. Conf. on Artificial Neural Networks*, Espoo, Finland, June 24-28 1991, Elsevier Science Publishers B. V. (North-Holland), 1991, pp. 835-840
- [9] Gonzalez, R.C. and Thomason, M.G.: *Syntactic Pattern Recognition*. London: Addison-Wesley, 1978
- [10] Niemann, H.: *Klassifikation von Mustern*. Berlin: Springer, 1983
- [11] Adamy, J.: Automatische Mapping-Identifikation bei der Querprofilregelung des Flächengewichts. *Das Papier* 6 (1994), pp. 324-334
- [12] Adamy, J.: Adaption der Flächengewichts-Querprofilregelung bei Papiermaschinen mittels einer Fuzzy-Entscheidungslogik. 4th Workshop "Fuzzy Control" of the GMA-UA 1.4.2, Dortmund, Germany, Nov. 3-4, 1994, *Berichtsband*, ISSN 0941-4169, pp. 108-119
- [13] Ercegovac, M.D. and Lang, T.: *Digital Systems and Hardware/Firmware Algorithms*. New York: John Wiley & Sons, 1985
- [14] Wee, W.G. and Fu, K.S.: A Formulation of Fuzzy Automata and its Application as a Model of Learning Systems. *IEEE Trans. Syst. Sci. & Cybern.*, vol. SSC-5, pp. 215-223, 1969
- [15] Lee, E.T.: Fuzzy Tree Automata and Syntactic Pattern Recognition. *IEEE Trans. Pattern Anal. Machine Intell.*, vol. PAMI-4, no.4, pp. 445-449, 1982
- [16] Kiendl, H. et.al.: Fuzzy Control. *Automatisierungstechnik* 41 (1993), pp. A1-A40
- [17] Kiendl, H.: The Inference Filter. *Second European Congress on Intelligent Techniques and Soft Computing (EUFIT)*, Aachen, Germany, pp. 443-447, Sept. 20-23, 1994
- [18] Zimmermann, H. J.: *Fuzzy-Set Theory - and Its Applications*. Kluwer-Nijhoff Publishing, Boston 1991